

# **VC-C50i**

**COMMUNICATION CAMERA**

**PROGRAMMER'S MANUAL**

## Contents

1. Getting Started.....	6
2. Connection with your Computer.....	6
2.1 Connection.....	6
2.2 Connector & Pin Assignment.....	7
3. Communication Format.....	7
3. Communication Format.....	8
3.1 Signal Format.....	8
3.2 Understanding.....	8
3.3 Communication Timing Diagram.....	9
4. Control Command Format.....	11
5. Answer Format.....	11
5.1 Answer Format.....	11
5.2 Error Code.....	11
5.3 Status.....	12
6. Function of Command Termination Notification.....	13
6.1 Function In General.....	13
6.2 Format of Command Termination Notification.....	13
7. Cascade Global Notification.....	13
7.1 In General.....	13
7.2 Format of Cascade Global Notification Data.....	14
7.3 Notification Code.....	14
8. Event Generation Notification Function.....	15
8.1 Overview of Event Generation Notification Function.....	15
8.2 Event Generation Notification Data Format.....	15
8.3 Event Generation Factor Codes.....	15
9. Function of Remote Control.....	16
9.1 In General.....	16
9.2 Data Format of Remote Control Through.....	16
9.3 Table of Remote Control Code.....	17
10. Classification of Command.....	18
10.1 Classification by Operation.....	18
10.2 Classification by Executive Format.....	18
11. Control Command Table.....	20
11.1 Pedestal Control Command Table.....	20
11.2 Camera Control Command Table.....	21
11.3 System Control Command Table.....	23
12. Details of Pedestal Control Commands.....	25
12.1 Pan Speed Assignment Pedestal Control Command Type 1.....	25
12.2 Tilt Speed Assignment Pedestal Control Command Type 1.....	26
12.3 Pan Speed Request Pedestal Control Command Type 1.....	27
12.4 Tilt Speed Request Pedestal Control Command Type 1.....	28
12.5 Pan Tilt Stop Pedestal control Command Type 1.....	29
12.6 Pan Right Start Pedestal Control Command Type 2.....	30
12.7 Pan Left Start Pedestal Control Command Type 2.....	31

12.8	Tilt Up Start	Pedestal Control Command Type 2	32
12.9	Tilt Down Start	Pedestal Control Command Type 2	33
12.10	Home Position	Pedestal Control Command Type 2	34
12.11	Pedestal Initialize 1	Pedestal Control Command Type 2	35
12.12	Pedestal Initialize 2	Pedestal Control Command Type 2	36
12.13	Pan Slowest Speed Request	Pedestal Control Command Type 1	37
12.14	Pan Fastest Speed Request	Pedestal Control Command Type 1	38
12.15	Tilt Slowest Speed Request	Pedestal Control Command Type 1	39
12.16	Tilt Fastest Speed Request	Pedestal Control Command Type 1	40
12.17	Pan Angle Pulse Ratio Request	Pedestal Control Command Type 1	41
12.18	Tilt Angle Pulse Ratio Request	Pedestal Control Command Type 1	42
12.19	Pan Minimum Angle Request	Pedestal Control Command Type 1	43
12.20	Pan Maximum Angle Request	Pedestal Control Command Type 1	44
12.21	Tilt Minimum Angle Request	Pedestal Control Command Type 1	45
12.22	Tilt Maximum Angle Request	Pedestal Control Command Type 1	46
12.23	Pan/Tilt Stop	Pedestal Control Command Type 1	47
12.24	Pan/Tilt Start Stop	Pedestal Control Command Type 2	48
12.25	Pan/Tilt Angle Assignment	Pedestal Control Command Type 2	50
12.26	Pan/Tilt Angle Request	Pedestal Control Command Type 1	52
12.27	Pan Movable Range Assignment	Pedestal Control Command Type 1	54
12.28	Tilt Movable Range Assignment	Pedestal Control Command Type 1	56
12.29	Pan Movable Range Request	Pedestal Control Command Type 1	58
12.30	Tilt Movable Range Request	Pedestal Control Command Type 1	59
13.	Details of Camera Control Commands		60
13.1	Camera OFF	Camera Control Command Type 2	60
13.2	Camera ON	Camera Control Command Type 2	61
13.3	Focus Automatic	Camera Control Command Type 1	62
13.4	Focus Manual	Camera Control Command Type 1	63
13.5	Focus Near	Camera Control Command Type 2	64
13.6	Focus Far	Camera Control Command Type 2	65
13.7	Focus Position Assignment	Camera Control Command Type 2	66
13.8	Focus Position Request	Camera Control Command Type 1	67
13.9	One Push AF	Camera Control Command Type 2	68
13.10	Focus Range Request	Camera Control Command Type 1	69
13.11	Zoom Stop	Camera Control Command Type 1	70
13.12	Zoom Wide	Camera Control Command Type 2	71
13.13	Zoom Tele	Camera Control Command Type 2	72
13.14	Zoom Hi Wide	Camera Control Command Type 2	73
13.15	Zoom Hi Tele	Camera Control Command Type 2	74
13.16	Zoom Position 1 Assignment	Camera Control Command Type 2	75
13.17	Zoom Position 1 Request	Camera Control Command Type 1	76
13.18	Zoom Position 2 Assignment	Camera Control Command Type 2	77
13.19	Zoom Position 2 Request	Camera Control Command Type 1	78
13.20	Zoom Speed Assignment	Camera Control Command Type 1	79
13.21	Zoom Speed Request	Camera Control Command Type 1	80
13.22	Zoom Position Maximum Request	Camera Control Command Type 1	81

13.23	Backlight Compensation OFF	Camera Control Command Type 2	82
13.24	Backlight Compensation ON	Camera Control Command Type 2	83
13.25	Exposure Automatic	Camera Control Command Type 1	84
13.26	Exposure Manual	Camera Control Command Type 1	85
13.27	AE Lock OFF	Camera Control Command Type 1	86
13.28	AE Lock ON	Camera Control Command Type 1	87
13.29	Shutter Speed Program	Camera Control Command Type 1	88
13.30	Shutter Speed 1/60 (PAL:1/50)	Camera Control Command Type 2	89
13.31	Shutter Speed 1/100 (PAL:1/120)	Camera Control Command Type 2	90
13.32	Shutter Speed Assignment	Camera Control Command Type 2	91
13.33	Shutter Speed Request	Camera Control Command Type 1	93
13.34	AGC Gain Assignment	Camera Control Command Type 1	95
13.35	AGC Gain Request	Camera Control Command Type 1	96
13.36	Iris Assignment	Camera Control Command Type 2	97
13.37	Iris Request	Camera Control Command Type 1	98
13.38	AE Target Value Assignment	Camera Control Command Type 2	100
13.39	AE Target Value Request	Camera Control Command Type 1	101
13.40	Auto White Balance Normal	Camera Control Command Type 1	102
13.41	Auto White Balance Lock	Camera Control Command Type 1	103
13.42	White Balance Manual Mode	Camera Control Command Type 2	104
13.43	White Balance Value Assignment	Camera Control Command Type 1	105
13.44	White Balance Value Request	Camera Control Command Type 1	106
13.45	Fade Normal	Camera Control Command Type 2	107
13.46	Fade White	Camera Control Command Type 2	108
13.47	Fade Hi Speed White	Camera Control Command Type 2	109
13.48	Fade Hi Speed Black	Camera Control Command Type 2	110
13.49	Camera Reset	Camera Control Command Type 2	111
13.50	Zoom Ratio Request	Camera Control Command Type 1	112
13.51	Pixel Size Request	Camera Control Command Type 1	113
13.52	Setting Insertion of Infrared Cut Filter	Camera Control Command Type 2	114
13.53	Settings when Infrared Cut Filter Not Inserted	Camera Control Command Type 2	115
13.54	Infrared Cut Filter Status Request	Camera Control Command Type 1	116
13.55	Electronic Zoom Setting	Camera Control Command Type 2	117
13.56	Electronic Zoom Setting Verification	Camera Control Command Type 2	118
13.57	Noise Reduction OFF	Camera Control Command Type 2	119
13.58	Noise Reduction Low Level ON	Camera Control Command Type 2	120
13.59	Noise Reduction High Level ON	Camera Control Command Type 2	121
13.60	Noise Reduction Setting Verification	Camera Control Command Type 1	122
13.61	Dome Mode Setting	Camera Control Command Type 2	123
13.62	Dome Mode Setting Verification	Camera Control Command Type 1	124
13.63	Product Version Request	Camera Control Command Type 1	125
13.64	EEPROM Version Request	Camera Control Command Type 1	126
14.	Details of System Control Commands		127
14.1	Alarm Output OFF	System Control Command Type 1	127
14.2	Alarm Output ON	System Control Command Type 1	128
14.3	Alarm Output Status Request	System Control Command Type 1	129

14.4	External Sensor Input Detection Setting	System Control Command Type 1	130
14.5	External Sensor Input Detection Status Request	System Control Command Type 1	131
14.6	External Sensor Input Detection Setting Information Request	System Control Command Type 1	132
14.7	Internal Infrared Light ON/OFF Control	System Control Command Type 1	133
14.8	Internal Infrared Light Status Request	System Control Command Type 1	134
14.9	External Light Output OFF	System Control Command Type 1	135
14.10	External Light Output ON	System Control Command Type 1	136
14.11	External Light Output Status Request	System Control Command Type 1	137
14.12	Remote Control ON	System Control Command Type 1	138
14.13	Remote Control OFF	System Control Command Type 1	139
14.14	Operation Status Request	System Control Command Type 1	140
14.15	Extended Operation Status Request	System Control Command Type 1	141
14.16	Operation Status 3 Request	System Control Command Type 1	143
14.17	Operation Status 4 Request	System Control Command Type 1	145
14.18	Product Name Request	System Control Command Type 1	147
14.19	ROM Version Request	System Control Command Type 1	148
14.20	Preset Set	System Control Command Type 1	149
14.21	Preset Move	System Control Command Type 2	150
14.22	Preset Status Request	System Control Command Type 1	152
14.23	Extended Preset Status Request	System Control Command Type 1	153
14.24	Remote Controller Through Setting	System Control Command Type 1	155
14.25	LED Normal Display	System Control Command Type 1	156
14.26	LED Forced Control	System Control Command Type 1	157
14.27	Cascade OFF	System Control Command Type 1	158
14.28	Cascade ON	System Control Command Type 2	159
14.29	Host Control Mode	System Control Command Type 1	160
14.30	Local Control Mode	System Control Command Type 1	161
14.31	Screen Control	System Control Command Type 1	162
14.32	Display Character Data Assignment	System Control Command Type 1	164
14.33	Display Character Data Request	System Control Command Type 1	166
14.34	Display Date Assignment	System Control Command Type 1	168
14.35	Display Date Request	System Control Command Type 1	169
14.36	Display Time Setting	System Control Command Type 1	170
14.37	Display Time Request	System Control Command Type 1	171
14.38	Turning ON Time Request	System Control Command Type 1	172
14.39	Default Setting	System Control Command Type 1	173
14.40	Command Termination Notification Setting	System Control Command Type 1	174
14.41	Global Notification Setting	System Control Command Type 1	175
14.42	Pedestal Model Request	System Control Command Type 1	176
14.43	Camera Model Request	System Control Command Type 1	177
15.	Connection Cable		178
15.1	Example 1 Connection with PC-AT		178
15.2	Example 2 Connection with PC-AT		179
15.3	Example Connection with Macintosh		180
15.4	Example of Connection Cables for Computer Side of VC-C50i		181
15.5	Example of Connection Cables for Next Camera Side of VC-C50i		182

15.6	Example of Connection Cables from VC-C50i to VC-C50i.....	183
16.	Example of Host Control Sequence .....	184
16.1	Assignment of Host Control Mode .....	184
16.2	Initial Setting .....	185
16.3	Command Termination Notification .....	186
16.4	Remote Controller Through .....	187
16.5	Cascade ON Assignment.....	188
16.6	Cascade Individual Assignment.....	189
16.7	Cascade Global Assignment.....	190

## 1. Getting Started

This manual describes commands which control communication camera VC-C50i through RS-232C interface from host computer.

Before reading this manual, it is recommended to read operation manual of VC-C50i.

### CAUTION:

VC-C50i/VC-C50iR Pan/Tilt operational durability is guaranteed for 100K cycles.

In case of the continuous operation by the program such as Auto Pan Tilt system, & etc., it is important not to overdrive the said value (100K).

## 2. Connection with your Computer

### 2.1 Connection

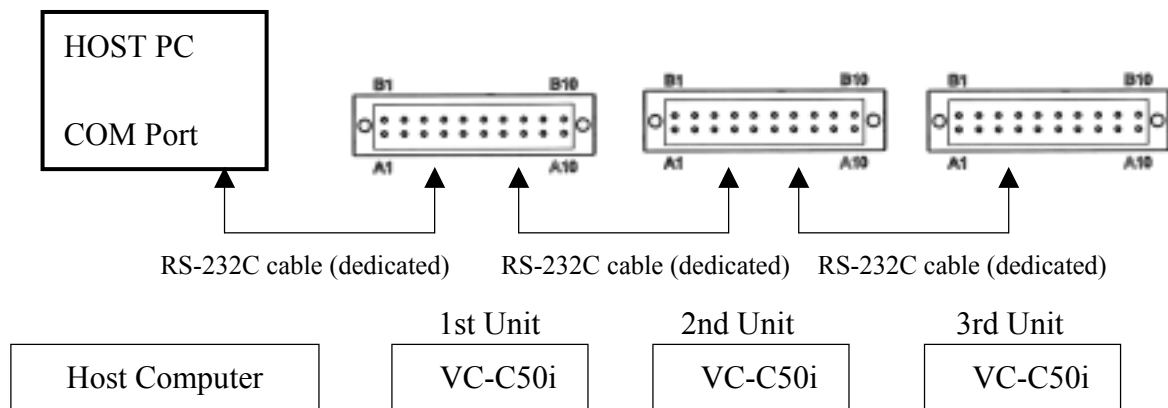

Use the supplied connector to connect the COM port on the host computer with the RS-232C terminal on the VC-C50i host side using a RS-232C dedicated cable.

For operation of multiple connected VC-C50i units, connect a RS-232C dedicated cable to the OUT side (next camera side) of the first VC-C50i unit's RS-232C terminal and to the IN side (host side) of the second VC-C50i unit's RS-232C terminal. Three or more units are connected in the same way, and up to nine VC-C50i units can be connected.

If a **Cascade ON** command is issued when multiple VC-C50i units are connected, the device numbers of the connected VC-C50i units are set as 1, 2, 3, and so on, starting from the host computer side.

If the VC-C50i is used as a single unit, there is no need for connections of a second or more units.

## 2.2 Connector & Pin Assignment

### RS-232C OUT

(Connection to Next Camera Side in Cascade Connection)

A3	RTS	Output	→ NEXT CAMERA	RS-232C cascade output send request
B3	CTS	Input	NEXT CAMERA →	RS-232C cascade output send permit
A4	TXD	Output	→ NEXT CAMERA	RS-232C cascade output send data
B4	RXD	Input	NEXT CAMERA →	RS-232C cascade output receive data
A5	GND			RS-232C cascade output GND

### RS-232C IN

(Connection to Host Side in Cascade Connection)

B5	GND			RS-232C input GND
A6	RTS	Output	→ Host PC	RS-232C input send request
B6	CTS	Input	Host PC →	RS-232C input send permit
A7	TXD	Output	→ Host PC	RS-232C input send data
B7	RXD	Input	Host PC →	RS-232C input receive data

Connector model: B2L 3.5/20 LH SN OR

Manufacturer: Weidmuller (supplied with product)

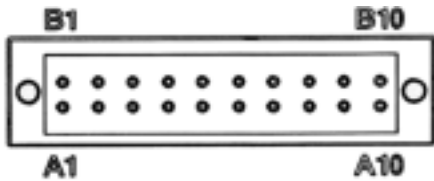

Camera side connector diagram



### 3. Communication Format

#### 3.1 Signal Format

RS-232C Conformity	Connector & Pin assignment of connector are referred to 2.2
Transmission Mode	: Half Duplex (Full duplex for notification)
Transfer Speed	: 4800, 9600, 14400, 19200bps. (selected through menu window)
Data Bit	: 8 bit
Parity	: None
Stop Bit	: 1 bit or 2 bit (selected through menu window)
Handshake	: RTS/CTS Control
Others	: One Acknowledge per command

#### RS-232C level Definitions

ON	: +5V to +15V
OFF	: -5V to -15V

#### 3.2 Understanding

The followings are described based on the signal from the computer terminal (RS-232C).

- The flow is controlled by RTS/CTS terminal control.
- When the VC-C50i is ready to receive control commands, the CTS line of the computer is ON. And as long as VC-C50i is turned on, the CTS line is always ON because VC-C50i is ready to receive the control commands.
- In case of starting the communication from the computer, the RTS line of computer must be ON.
- After receiving the answer corresponding to the control command, the next control commands will be ready to transmit.  
Before transmitting the answer corresponding to the control command, VC-C50i cancels the received code, in case of receiving the next control commands.
- In case of not receiving the answer to the computer, the RTS line of the computer must be OFF. In this case, VC-C50i will suspend to issue the answer. If VC-C50i, however, suspends more than one second, the issue of the answer will be forced to stop and VC-C50i returns to the receiving status.
- In case of using the notification functions, the communication format must correspond to full duplex. There are some cases for VC-C50i to issue the notification data, while the computer issues the commands.
- The standard waiting time of the answer is 300ms. If VC-C50i does not return the answer more than 300ms, there must be some errors.
- Note that VC-C50i is unable to execute remote control and communication control at a one time. After turn on, VC-C50i is under the condition of remote control. If the communication control is required, **Host Control Mode** command or **Cascade ON** command must be issued. Note that the VC-C50i can not shift the remote control status to the host communication control mode during menu processing.

### 3.3 Communication Timing Diagram

#### Example 1: Basic communication

##### Computer Side

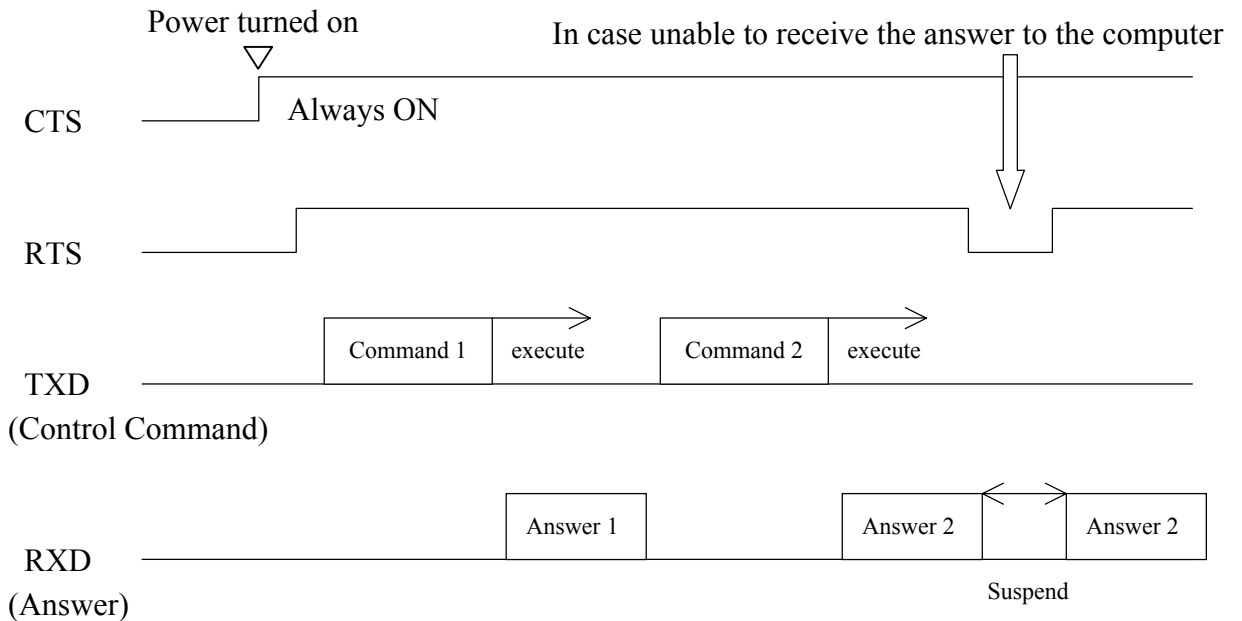

#### Example 2: Unable to execute the commands due to error

The details are referring to **12.1 Pan Speed Assignment** command.

The followings shows the case which causes the error by **Pan Speed Assignment** command, when the communication mode isn't host mode. **Pan Speed Assignment** commands will cause the error mode under the condition that the communication mode is not host mode.

After the error generated by **Pan Speed Assignment** command, the **Operation Status Request** command is issued and confirms that the error source isn't host mode, then the **Host Control** command is issued and **Pan Speed Assignment** command is again executed.

##### Computer Side

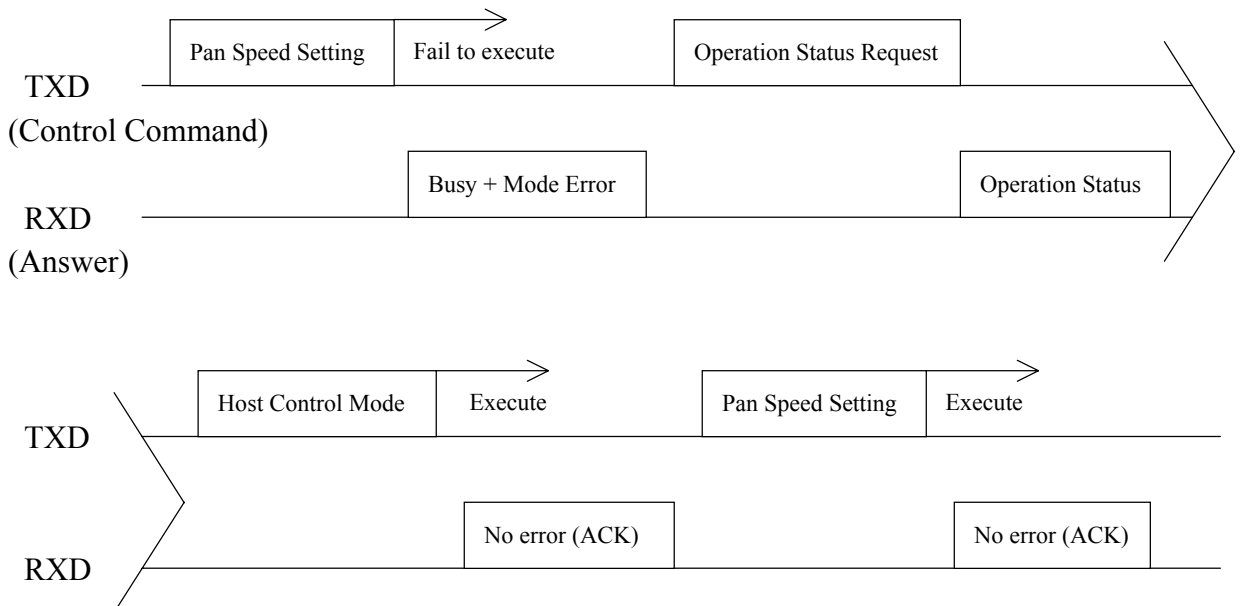

### **Example 3: The case using Remote Control Through Function**

The details are referring to **9. Function of Remote Control**.

As shown below, there are some cases that the commands and remote control through data are generated at the same time, while remote control through function turns on the RTS line of computer. In this case, the software of computer must correspond to full duplex.

#### **Computer Side**

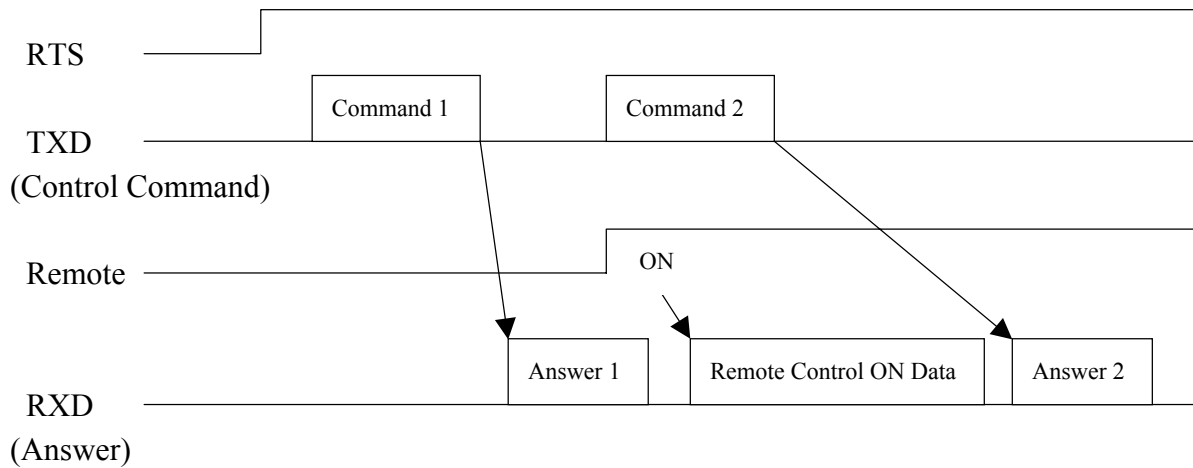

### **Example 4: The case using the Function of Command Termination Notification**

The details are referring to **6. Function of Command Termination Notification**.

As shown below, there are some cases that the commands and remote control through data are generated at the same time, while the function of command termination notification turns on the RTS line of computer. In this case, the software of computer must correspond to full duplex.

#### **Computer Side**

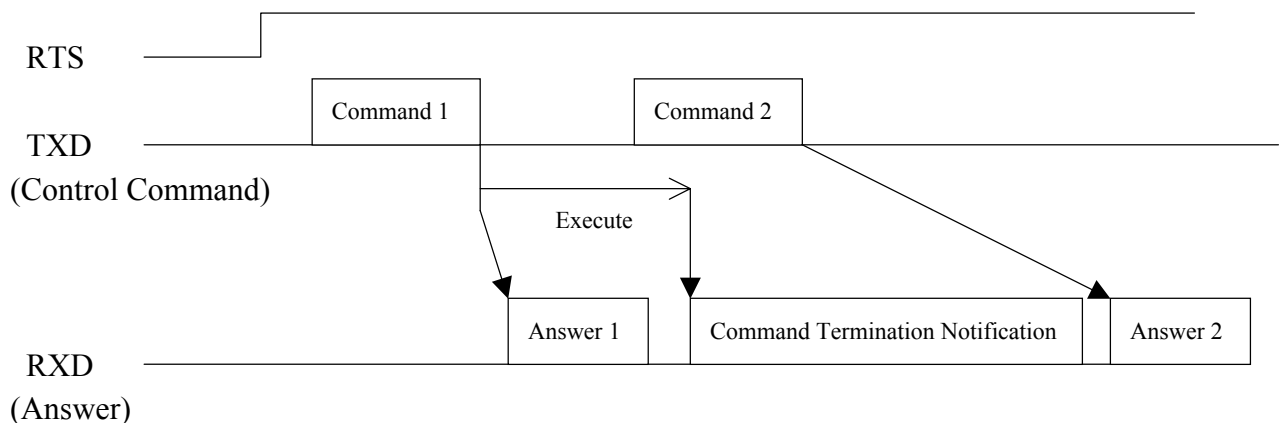

#### 4. Control Command Format

This format is to transmit from the computer to VC-C50i.

Header	Device Num	Command	Parameter	End mark
--------	------------	---------	-----------	----------

Header : 1 byte FFh

Device Num : 2 byte 3030h~3039h (Device number in cascade connection)

Command : 2 byte (refer to **12. Details of Pedestal Control Commands**  
~ **14. Details of System Control Commands**)

Parameter : Variable length If not specified, parameter manifests hexadecimal, transmits its ASCII code.

End mark : 1 byte EFh

Just after power on, device number is 3030 and each device number is determined by **Cascade ON** control command.

The control command (Global Command) of device number 3030 became valid to all VC-C50i connected in **Cascade ON** status.

#### 5. Answer Format

##### 5.1 Answer Format

This answer format corresponds to the control command transmitted from the computer to VC-C50i.

Header	Device Num	Error Code	Status	End mark
--------	------------	------------	--------	----------

Header : 1 byte FEh

Device Num : 2 byte 3030h~3039h (Device number in cascade connection)

Error Code : 2 byte manifested error flag In hexadecimal and return it's ASCII code.

Status : Variable length If not specified, status manifests hexadecimal, transmits its ASCII code.

End mark : 1 byte EFh

Under the condition in **Cascade Connection ON**, the answer corresponding to control command of device number 3030, is returned only to the last device connected in cascade.

##### 5.2 Error Code

Error code manifests error flag in hexadecimal and returns it's ASCII code. If not exists error, all bits of error flags are cleared and becomes zero.

- The bit assignment of error flag.

b7(MSB)	b6	b5	b4	b3	b2	b1	b0(LSB)
Mode error	Parameter error	Command error	Busy	System reservation	System reservation	System reservation	System error

1st byte	b7: Mode Error	In case of wrong mode
	b6: Parameter Error	In case of receiving wrong parameter
	b5: Command Error	In case of receiving wrong command
	b4: Busy	In case of unable to execute by error

2nd byte	b3: System Reservation	Always zero
	b2: System Reservation	Always zero
	b1: System Reservation	Always zero
	b0: System Error	In case of the fatal error to the system

The details of error flags are described as below.

Busy	: VC-C50i is unable to execute the commands in process to execute the former command.
	: In case of generating Command Error, Parameter Error, Mode Error or System Error.
Command Error	: In case of receiving the wrong commands (not prepared commands).
Parameter Error	: In case of over value of parameter or wrong parameter length.
Mode Error	: In case of receiving the command unable to execute under VC-C50i during the receiving status.
System Error	: In case that the fatal accidents occur for some reason.

### **CAUTION**

- If the device number is wrong, its control command code will be ignored.
- By **Operation Status Request**, the cause of error can be found.
- The error check will be executed by the following priority order.
  - (1) Mode Error
  - (2) Command Error
  - (3) Parameter Error, Busy

VC-C50i sets the error flag corresponding to any, after the detection of error, and returns the answer, then multiple error flags can't be set. Busy, however, is exceptional and set, whenever any of Command Error, Parameter Error, Mode Error or System Error occurs.

Example: Wrong command to be transmitted.

<u>1st byte</u> b7 = 0, b6 = 0, b5 = 1, b4 = 1 3h → 33h	<u>2nd byte</u> b3 = 0, b2 = 0, b1 = 0, b0 = 0 0h → 30h
(Hexadecimal indication → ASCII code conversion)	

Note: When the command errors occur and unable to execute, busy flag and command error flag will be set at the 1.

### **5.3 Status**

In case of having received status request command, this status adds status value to the answer. The details of **Operation Status Request** command and status value are described later. (Refer to **14. Details of System Control Commands**)

The **Operation Status Request** will accept the command, if not host control mode.

## 6. Function of Command Termination Notification

### 6.1 Function In General

Among the control commands of VC-C50i, the **executive format type 2** has the function of the termination notification at the time terminated to executed. (the details of executive format refers to **10. Classification of Command**) The termination notification to be admitted or forbidden will be executed by the ON/OFF command of the termination notification.

Note 1 : After just turn on, the function of command termination notification is set under the condition of forbidden status.

Note 2 : In case of using this function, the software of computer must correspond to full duplex, in order to be able to receive the termination notification data, even if the computer issues the commands.

Note 3 : The RTS line must be always ON, in order not to forbid the transmission of notification data during the flow control.

Note 4 : The details of the communication timing are referring to **3.3 Communication Timing Diagram**.

### 6.2 Format of Command Termination Notification

Before the time to terminate the execution, the data format from VC-C50i to the computer is configured as shown below.

Header	Device Num	Command	Parameter	End mark
--------	------------	---------	-----------	----------

Header : 1 byte FAh

Device Num : 2 byte 3030h~3039h (Device number in cascade connection.)

Command : 2 byte Command at the time of the operation terminated.

Parameter : Variable length Parameter at the time of the operation terminated.

End mark : 1 byte EFh

Under the status of **Cascade ON**, the command termination notification will be returned from each device, corresponding to the control command of Device Num. 3030. (device number 3031~3039)

## 7. Cascade Global Notification

### 7.1 In General

In case of using VC-C50i connected in cascade, the global commands (Device number 3030h) can execute the identical operation to all VC-C50i connected in cascade. But the only last device will return the answer to the computer. In case of the cascade global notification function admitted and global command issued, the only error information integrated among the answer information of VC-C50i is notified to the computer.

Note 1 : After just turn on, the function of command termination notification is of setting the forbidden status.

Note 2 : In case of using this function, the software of computer must correspond to full duplex, in order to be able to receive the termination notification data, even if the computer issues the commands.

Note 3 : The RTS line must be always ON, in order not to forbid the transmission of notification data during the flow control.

Note 4 : The details of the communication timing are referring to **3.3 Communication Timing Diagram**.

## 7.2 Format of Cascade Global Notification Data

Before the time to terminate the execution, the data format from VC-C50i to the computer is configured as shown below.

Header	Device Num	Notification Code	End mark
Header	: 1 byte	F8h	
Device Num	: 2 byte	3031h~3039h (Last device number connected in cascade.)	
Notification Code	: 4 byte	Present information of VC-C50i connected.	
End mark	: 1 byte	EFh	

## 7.3 Notification Code

The error information of VC-C50i connected in cascade indicates in hexadecimal, returns its ASCII code. If the error does not exist, all bits of notification flags will be cleared and become zero.

### • Bit Assignment of Error Flags.

b15(MSB)	b14	b13	b12	b11	b10	b9	b8
System Resv.(0)	System Resv.(0)	System Resv.(0)	System Resv.(0)	System Resv.(0)	System Resv.(0)	System Resv.(0)	Cascade 9 <sup>th</sup>
b7	b6	b5	b4	b3	b2	b1	b0(LSB)
Cascade 8 <sup>th</sup>	Cascade 7 <sup>th</sup>	Cascade 6 <sup>th</sup>	Cascade 5 <sup>th</sup>	Cascade 4 <sup>th</sup>	Cascade 3 <sup>rd</sup>	Cascade 2 <sup>nd</sup>	Cascade 1 <sup>st</sup>

Example: 6 units are connected in cascade, and the errors occur in 1<sup>st</sup> unit and 5<sup>th</sup> unit.

<u>1st byte</u> b15 = 0, b14 = 0, b13 = 0, b12 = 0 0h → 30h (Hexadecimal indication → ASCII code conversion)	<u>2nd byte</u> b11 = 0, b10 = 0, b9 = 0, b8 = 0 0h → 30h (Hexadecimal indication → ASCII code conversion)
<u>3<sup>rd</sup> byte</u> b7 = 0, b6 = 0, b5 = 0, b4 = 1 1h → 31h (Hexadecimal indication → ASCII code conversion)	<u>4<sup>th</sup> byte</u> b3 = 0, b2 = 0, b1 = 0, b0 = 1 1h → 31h (Hexadecimal indication → ASCII code conversion)

Example of Notification data

d0	d1	d2	d3	d4	d5	d6	d7
Header	Device Num		Notification Code			End mark	
F8h	30h	36h	30h	30h	31h	31h	EFh

## 8. Event Generation Notification Function

### 8.1 Overview of Event Generation Notification Function

This function notifies the computer side about event information generated in the VC-C50i. The types of notification events can be set by selecting the commands for the event generation notification function.

### 8.2 Event Generation Notification Data Format

When an event is generated, the data sent from the VC-C50i to the computer has the following format.

Header	Device Num	Notification Code	Parameter	End mark
Header	: 1 byte	FBh		
Device Num	: 2 byte	3031h~3039h (Device number in cascade connection.)		
Notification Code	: 2 byte	Event generation factor code.		
Parameter	: 2 byte	Event generation factor parameter.		
End mark	: 1 byte	EFh		

### 8.3 Event Generation Factor Codes

Commands related to the generated event are set.

Example: When the detection conditions are found with the external sensor input detection set (74h command) .

d0	d1	d2	d3	d4	d5	d6	d7
Header	Device Num		Notification Code		Parameter		End mark
FBh	30h	3Xh	00h	74h	30h	30h	EFh



The external sensor input detection setting command is set.



## 9. Function of Remote Control

### 9.1 In General

The ON/OFF status of remote control can be monitored by the computer.

By **Remote Control Through** command ON, VC-C50i is in the status of through mode and notify the status of ON/OFF to the computer.

If the control mode is set to remote through ON by host control, the VC-C50i sends the status corresponding to the pressed key directly to the computer side without performing any operation for any received remote control code. If the control mode is set to remote through ON by remote control, the VC-C50i performs the operation corresponding to the received remote control code, and then sends the status to the computer side.

Note 1 : After just turn on, the function of remote control is of setting the status OFF.

Note 2 : In case of using this function, the software of computer must correspond to full duplex, in order to be able to receive the remote control through data, even if the computer issues the commands.

Note 3 : The RTS line must be always ON, in order not to forbid the remote control through data during the flow control.

Note 4 : The details of the communication timing are referring to **3.3 Communication Timing Diagram**.

### 9.2 Data Format of Remote Control Through

At the time to receive remote control data, the data format from VC-C50i to the computer is configured as shown below.

Header	Device Num	Status	End mark
Header	: 1 byte	FDh Remote Button ON (Pushed) FCh Remote Button OFF (Released)	
Device Num	: 2 byte	3030h~3039h (Device number in cascade connection.)	
Status	: 2 byte	Remote control code indicates hexadecimal, returns its ASCII code. (refer to <b>9.3. Table of Remote Control Code</b> )	
End mark	: 1 byte	EFh	

Each device return the data of remote control in the status of cascade connection (3031~3039).

Example: Remote Control Button [1] ON

d0	d1	d2	d3	d4	d7
Header	Device Num		Remote control Code		End mark
FDh	30h	3Xh	30h	31h	EFh

Example: Remote Control Button [1] OFF

d0	d1	d2	d3	d4	d7
Header	Device Num		Remote control Code		End mark
FCh	30h	3Xh	30h	31h	EFh

### 9.3 Table of Remote Control Code

At the remote control through mode, the code corresponding to the key transmitted by VC-C50i, is described below.

Command of remote control (Remote Key)	Code	Status Value
MF	00h	30 30h
1	01h	30 31h
2	02h	30 32h
3	03h	30 33h
4	04h	30 34h
5	05h	30 35h
6	06h	30 36h
AF	07h	30 37h
NEAR	08h	30 38h
FAR	09h	30 39h
WIDE	0Ah	30 41h
TELE	0Bh	30 42h
UP	0Ch	30 43h
DOWN	0Dh	30 44h
LEFT	0Eh	30 45h
RIGHT	0Fh	30 46h
HOME	10h	31 30h
ID	11h	31 31h
BRIGHT-	12h	31 32h
ON SCREEN	13h	31 33h
CAMERA	14h	31 34h
SET/OK	15h	31 35h
CANCEL	16h	31 36h
*	17h	31 37h
#	18h	31 38h
BRIGHT+	19h	31 39h
Fn	1Ah	31 41h
MENU	1Bh	31 42h
7	1Ch	31 43h
8	1Dh	31 44h
9	1Eh	31 45h
0	1Fh	31 46h

## 10. Classification of Command

### 10.1 Classification by Operation

VC-C50i consists of pedestal and camera sections, and command consists of Pedestal Control, Camera Control and System Control. This manual describes according to this classification.

#### (1) Pedestal Control

This control is to set each parameter, to inquire and to indicate operation for pedestal.

**Pan Speed Assignment, Pan Speed Request, Pan Angle Request**, etc. are counted among this classification. See the table **11.1 Pedestal Control Command Table**, and **12. Details of Pedestal Control Commands**.

#### (2) Camera Control

This control is to set each parameter, to inquire and to indicate operation for camera.

**Zoom Position Request, Parameter Setting**, etc.. are counted among this classification. See the Table **11.2 Camera Control Command Table**, and **13. Details of Camera Control Commands**.

#### (3) System Control

This control is to control the operation by remote control, to control LED display, operation of both camera and pedestal, to inquire the inside status and etc.

**Remote ON/OFF, LED Forced Control, Preset Setting, Status Request of Operation** are counted among this classification.

See the table **11.3 System Control Command Table**, and **14. Details of System Control Commands**.

### 10.2 Classification by Executive Format

Each command classify as one of Synchronous Execution (type 1) and other of Non-Synchronous Execution A (type 2).

#### (1) Synchronous Execution (type 1)

This command executes immediately at the time of command receipt, and complete the execution at the time of the answer completed.

The command among this classification enable to accept the next command at the moment of answer transmission. This classified commands describe as **type 1** in **12. Detail of Pedestal Control Commands ~ 14. Details of System Control Commands**.

Timing diagram describes below.

The answering time after receipt of the command code is 10 ms in standard, and 30 ms Max. And the execution completes at the beginning of transmission.

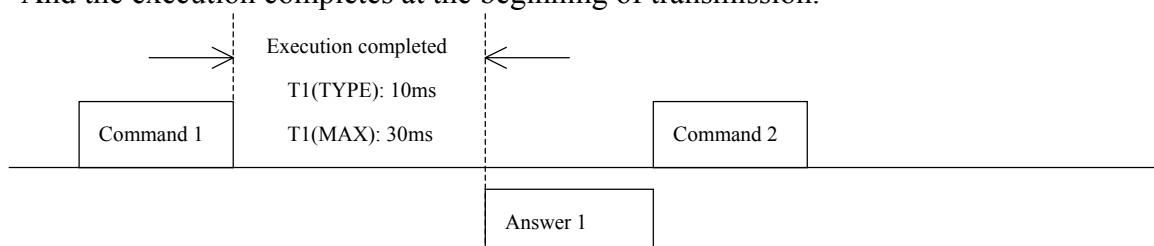

(2) Non-Synchronous Execution A (type 2)

On receipt of the command code, this command transmits the command without waiting of the completion to execute. The completion of operation can be found by the status of flag among the operation status, or by the Termination Notification of **Command Termination Notification**.

The commands classified in this, describe in **12. Details of Pedestal Control Command ~ 14. Details of System Control Commands as type 2**.

Timing diagram of the operation describes below.

The answering time after receipt of the command code, is 10 ms standard, 30 ms Max.

The time between start and stop, is depend on the class of commands and condition to be executed.

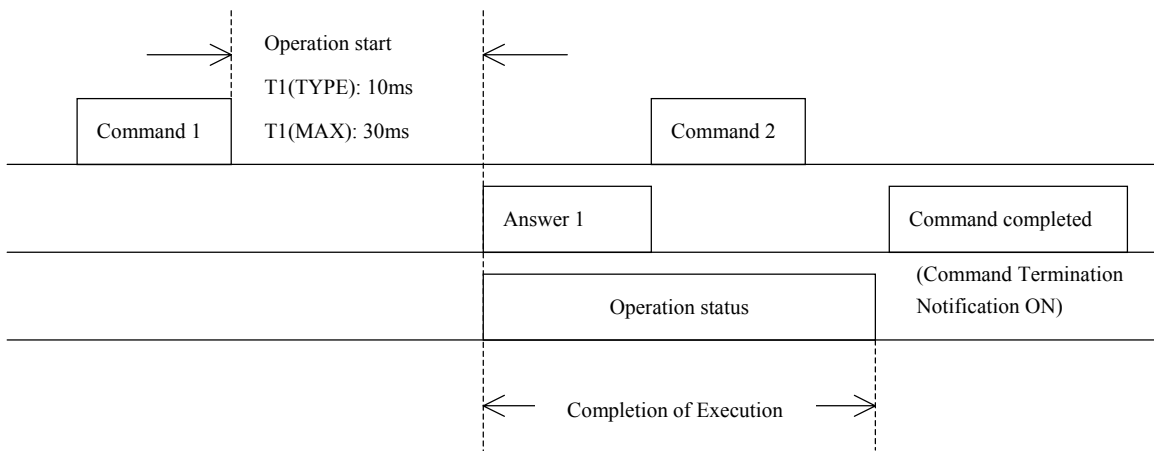

**NOTE**

The time shown above indicates the case of single VC-C50i to be connected with the host computer.

In case of multiple connection in cascade, the time delay (30 ms Max.) will occur according to the number of VC-C50i.

## 11. Control Command Table

### 11.1 Pedestal Control Command Table

Function	Meaning	Command	Parameter	Status	Ref
Pan Speed Assignment	To set running speed for Pan	0050h	008h~320h	None	P 25
Tilt Speed Assignment	To set running speed for Tilt	0051h	008h~26Eh	None	P 26
Pan Speed Request	To return present running speed for Pan	0052h	0h	008h~320h	P 27
Tilt Speed Request	To return present running speed for Tilt	0052h	1h	008h~26Eh	P 28
Pan Tilt Stop	To stop running of Pan/Tilt	0053h	0h	None	P 29
Pan Right Start	To start Pan running to right	0053h	1h	None	P 30
Pan Left Start	To start Pan running to left	0053h	2h	None	P 31
Tilt Up Start	To start Tilt running to up	0053h	3h	None	P 32
Tilt Down Start	To start Tilt running to down	0053h	4h	None	P 33
Home Position	To move Home position	0057h	None	None	P 34
Pedestal Initialize 1	After Initialization, to move home position	0058h	0h	None	P 35
Pedestal Initialize 2	After Initialized, to move the origin position	0058h	1h	None	P 36
Pan Slowest Speed Request	To return the slowest speed of Pan	0059h	0h	008h	P 37
Pan Fastest Speed Request	To return the fastest speed of Pan	0059h	1h	320h	P 38
Tilt Slowest Speed request	To return the slowest speed for Tilt	0059h	2h	008h	P 39
Tilt Fastest Speed request	To return the fastest speed for Tilt	0059h	3h	26Eh	P 40
Pan Angle Pulse Ratio Request	To return coefficient of Pan angle conversion	005Bh	0h	2BF2h	P 41
Tilt Angle Pulse Ratio Request	To return coefficient of Tilt angle conversion	005Bh	1h	2BF2h	P 42
Pan Minimum Angle Request	To return minimum angle of Pan	005Ch	0h	7C87h (7A19h)	P 43
Pan Maximum Angle Request	To return maximum angle of Pan	005Ch	1h	8379h (85E7h)	P 44
Tilt Minimum Angle Request	To return minimum angle of Tilt	005Ch	2h	7EF5h (7CE0h)	P 45
Tilt Maximum Angle Request	To return maximum angle of Tilt	005Ch	3h	8320h (8059h)	P 46
Pan/Tilt Stop	To stop Pan/tilt running	0060h	00h	None	P 47
Pan/Tilt Start Stop	To start and stop Pan/tilt running	0060h	01h~22h	None	P 48
Pan/Tilt Angle Assignment	To move assign position of Pan/Tilt	0062h	XXXX, YYYYh	None	P 50
Pan/Tilt Angle Request	To return present position of Pan/Tilt	0063h	None	XXXX, YYYYh	P 52
Pan Movable Range Assignment	To assign movable limit for Pan	0064h	0h, PMIN, PMAX	None	P 54
Tilt Movable Range Assignment	To assign movable limit for Tilt	0064h	1h, TMIN, TMAX	None	P 56
Pan Movable Range Request	To return present position of Pan	0065h	0h	PMIN, PMAX	P 58
Tilt Movable Range Request	To return present position of Tilt	0065h	1h	TMIN, TMAX	P 59

Note: XXXX, YYYY means Pan angel, Tilt angle in hexadecimal.

PMIN, PMAX means Pan min. movable range, max. movable range in hexadecimal.

TMIN, TMAX means Tilt mini. movable range, max. movable range in hexadecimal.

The value inside ( ) means status value in the inverse mount type.

## 11.2 Camera Control Command Table

Function	Meaning	Command	Parameter	Status	Ref
Camera OFF	To turn OFF power for Camera section	00A0h	0h	None	P 60
Camera ON	To turn ON power for Camera section	00A0h	1h	None	P 61
Focus Auto	To change mode of focus to AF	00A1h	0h	None	P 62
Focus Manual	To stop and change of focus to Manual	00A1h	1h	None	P 63
Focus Near	To move to near focus	00A1h	2h	None	P 64
Focus Far	To move to far focus	00A1h	3h	None	P 65
Focus Position Assignment	To move to focus position assigned	00B0h	XXXXh *1	None	P 66
Focus Position Request	To return present focus position	00B1h	0h	XXXXh *1	P 67
One Push AF	After adjustment of focus, change to MF	00B1h	1h	None	P 68
Focus Range Request	To return movable range of focus	00B1h	2h	XXXXXXXXh *2	P 69
Zoom Stop	To stop zoom operation	00A2h	0h	None	P 70
Zoom Wide	To zooming to wide	00A2h	1h	None	P 71
Zoom Tele	To zooming to tele	00A2h	2h	None	P 72
Zoom Hi Wide	To zooming to wide high speed	00A2h	3h	None	P 73
Zoom Hi Tele	To zooming to tele high speed	00A2h	4h	None	P 74
Zoom Position 1 Assignment	To move to zoom position assigned	00A3h	00h~80h	None	P 75
Zoom Position 1 Request	To return present zoom position	00A4h	None	00h~80h	P 76
Zoom Position 2 Assignment	To move to zoom position assigned	00B3h	0000h~07A8h	None	P 77
Zoom Position 2 Request	To return present zoom position	00B4h	0h	0000h~07A8h	P 78
Zoom Speed Assignment	To assign running speed of zoom	00B4h	“31h”, 0h~7h	None	P 79
Zoom Speed Request	To return present running speed	00B4h	2h	0h~7h	P 80
Zoom Maximum Request	To return maximum movable position	00B4h	3h	07A8h	P 81
Backlight Compensation OFF	To eliminate compensation of backlight	00A5h	0h	None	P 82
Backlight Compensation ON	To compensate backlight	00A5h	1h	None	P 83
Exposure Auto	To control exposure automatically	00A5h	2h	None	P 84
Exposure Manual	To control exposure manually	00A5h	3h	None	P 85
AE Lock OFF	To cancel AE lock ON	00A5h	40h	None	P 86
AE Lock ON	To lock the exposure of AE mode	00A5h	41h	None	P 87
Shutter Speed Program	To change shutter speed to program mode	00A8h	0h	None	P 88
Shutter Speed 1/60 (PAL: 1/50)	To change shutter speed to 1/60 (PAL: 1/50)	00A8h	1h	None	P 89
Shutter Speed 1/100 (PAL: 1/120)	To change shutter speed to 1/100 (0PAL: 1/120)	00A8h	2h	None	P 90
Shutter Speed Assignment	To assign shutter speed	00A5h	“35h”, 00h~1Bh 80h~83h	None	P 91
Shutter Speed Request	To return present shutter speed	00A5h	6h	00h~1Bh 80h~83h	P 92
AGC Gain Assignment	To assign AGC Gain	00A5h	“37h”, 00h~FFh	None	P 94
AGC Gain Request	To return present AGC gain	00A5h	8h	00h~FFh	P 95
Iris Assignment	To assign iris	00A5h	“39h”, 02h~11h	None	P 96
Iris Request	To return iris value	00A5h	“3Ah”	00h~12h	P 97
AE Target Value Assignment	To assign target value of AE brightness	00A5h	“3Bh”, 10h~FFh	None	P 99
AE Target Value Request	To return target value of AE brightness	00A5h	“3Ch”	10h~FFh	P 100
Auto White Balance Normal	To adjust white balance automatically	00A7h	0h	None	P 101
Auto White Balance Lock	To stop white balance control	00A7h	1h	None	P 102
White Balance Manual Mode	To set white balance manually	00A7h	2h	None	P 103
White Balance Value Assignment	To assign white balance manually	00A7h	“34h”, 00h~FFh	None	P 104
White Balance Value Request	To return present white balance manually	00A7h	5h	00h~FFh	P 105
Fade Normal	To fade out normal image slowly	00A9h	0h	None	P 106
Fade White	To fade in white image slowly	00A9h	1h	None	P 107
Fade Hi Speed White	To change to white image high speed	00A9h	2h	None	P 108
Fade Hi Speed Black	To change to black image high speed	00A9h	3h	None	P 109
Camera Reset	To reset Camera section	00AAh	None	None	P 110
Zoom Ratio request	To return zoom ratio of camera	00ABh	None	10h	P 111
Pixel Size Request	To return CCD pixel size	00ACh	None	14h	P 112
Insertion of Infrared Cut Filter	Sets the status when infrared cut filter is inserted	00B5h	1h	None	P 113
Settings when Infrared Cut Filter Not Inserted	Sets the status when infrared cut filter is not inserted.	00B5h	0h	None	P 114
Infrared Cut Filter Status Request	Returns the setting status of the infrared cut filter.	00B6h	None	0h or 1h	P 115
Electronic Zoom Setting	Sets the electronic zoom to the designated magnification.	00B7h	2 byte (magnification)	None	P 116
Electronic Zoom Setting Verification	Returns the electronic zoom magnification that was set.	00B8h	None	00h~10h	P 117

Noise Reduction OFF	Sets the noise reduction to OFF.	00b9h	0h	None	P 118
Noise Reduction Low Level ON	Sets the noise reduction to low level ON.	00B9h	1h	None	P 119
Noise Reduction High Level ON	Sets the noise reduction to high level ON.	00B9h	2h	None	P 120
Noise Reduction Setting Verification	Returns the noise reduction setting value.	00BAh	None	0h~2h	P 121
Dome Mode Setting	Sets the Dome mode to the designated value.	00BDh	“30 30h”, 0h~03h	None	P 122
Dome Mode Setting Verification	Returns the Dome mode setting value.	00BDh	01h	0h~03h	P 123
Product Version Request	To return version value of camera section	00BEh	0h	00h~FFh	P 124
EEPROM Version Request	to return version of camera EEPROM	00BEh	1h	00h~FFh	P 125

\*1 4 figures hexadecimal value within the request of focus limit.

\*2 The focus range changes according to the zoom position. The value indicates Max/Min 4 figures in hexadecimal.

### 11.3 System Control Command Table

Function	Meaning	Command	Parameter	Status	Ref
Alarm Output OFF	Sets the alarm output (+/- terminal) to Open.	0072h	0h	None	P 126
Alarm Output ON	Sets the alarm output (+/- terminal) to Closed.	0072h	1h	None	P 127
Alarm Output Status Request	Returns the alarm output setting status.	0073h	None	0h or 1h	P 128
External Sensor Input Detection Setting	External sensor input detection disabled	0074h	00h	None	P 129
External Sensor Input Detection Setting	External sensor input detection enabled with notification of changes from Closed to Open	0074h	01h	None	P 129
External Sensor Input Detection Setting	External sensor input detection enabled with notification of changes from Open to Closed	0074h	10h	None	P 129
External Sensor Input Detection Setting	External sensor input detection enabled with notification of changes from Closed to Open and notification of changes from Open to Closed	0074h	11h	None	P 129
External Sensor Input Detection Status Request	Returns external sensor input detection status.	0075h	None	0h or 1h	P 130
External Sensor Input Detection Setting Information Request	Returns the external sensor input detection setting status.	0075h	0h	00h or 01h or 10h or 11h	P 131
Internal Infrared Light ON/OFF Control	Sets the internal infrared light ON/OFF control.	0076h	0h~6h	None	P 132
Internal Infrared Light Status Request	Returns the internal infrared light ON/OFF setting status.	0077h	None	1 byte	P 133
External Light Output OFF	Sets the external light output (+/- terminal) to Open.	0078h	0h	None	P 134
External Light Output ON	Sets the external light output (+/- terminal) to Closed.	0078h	1h	None	P 135
External Light Output Status Request	Returns the setting status of the external light output terminal.	0079h	None	1 byte	P 136
Remote Control ON	To available remote controller	0080h	0h	None	P 137
Remote Control OFF	To inhibited remote controller	0080h	1h	None	P 138
Operation Status Request	To return information of operate status	0086h	None	3 byte	P 139
Extended Operation Status Request	To return extended information of operate status	0086h	0h	5 byte	P 140
Operation Status 3 Request	To return information of operate status 3	0086h	1h	4 byte	P 142
Operation Status 4 Request	To return information of operate status 4	0086h	2h	2 byte	P 144
Product Name Request	To return product name	0087h	None	"C50i" or "C50iR"	P 146
ROM Version Request	To return ROM version of VC-C4	0088h	None	"V1-01"	P 147
Preset Set	To memory preset position	0089h	1h~9h	None	P 148
Preset Move	To move preset position	008Ah	1h~9h	None	P 149
Preset Status Request	To request preset status	008Bh	None	2 byte	P 151
Extended Preset Status Request	To request extended preset status	008Bh	0h	3 byte	P 152
Remote Controller Through Setting	To set ON/OFF of remote controller through	008Dh	0h~1h	None	P 154
LED Normal Display	To set normal display of LED	008Eh	0h	None	P 155
LED Forced Control	To set forced ON/OFF of LED	008Eh	1h~4h	None	P 156
Cascade OFF	To release cascade connection OFF	008Fh	0h	None	P 157
Cascade ON	To connect cascade connection ON	008Fh	1h	None	P 158
Host Control Mode	To control by host computer	0090h	0h	None	P 159
Local Control Mode	To control by remote controller	0090h	1h	None	P 160
Screen Control	To set screen display of date, time, characters	0091h	00h~09h	None	P 161
Display Character Data Assignment	To assign character data of display	0091h	1h XX,Y,DD	None	P 163
Display Character Data Request	To request character data of display	0091h	2h XX,Y	2 byte	P 165
Display Date Setting	To set display date (yy/mm/dd)	0091h	3h YY,MM,DD	None	P 167



Display Date Request	To request display date (yy/mm/dd)	0091h	4h	YY,MM,DD	P 168
Display Time Setting	To set display time (hh/mm/ss)	0091h	5h,HH,MM,SS	None	P 169
Display Time Request	To request display time (hh/mm/ss)	0091h	6h	HH,MM,SS	P 170
Turning On Time Request	To request total accumulated turn on time	0092h	0h~1h	0000h~FFFFh	P 171
Default Setting	To initialize in status of factory setting	0093h	None	None	P 172
Command Termination Notification Setting	To set termination notification ON/OFF	0094h	0h~1h	None	P 173
Global Notification Setting	To set global notification ON/OFF	0095h	0h~1h	None	P 174
Pedestal Model Request	To return pedestal model (normal/inverse)	009Ah	0h	0h or 1h	P 175
Camera Model Request	To return camera model (NTSC/PAL)	009Ah	1h	0h or 1h	P 176

Note: XX, Y, DD indicate X address, Y address, character data of display in hexadecimal  
YY, MM, DD indicate year, month, day in hexadecimal.  
HH, MM, SS indicate hour, minute, second in hexadecimal.

## 12. Details of Pedestal Control Commands

### 12.1 Pan Speed Assignment

Pedestal Control Command Type 1

Function	To set running speed of Pan direction.	
Command	0050h	
Parameter	Length	3 byte
	Range	8~800PPS (008h~320h)
	Default Value	800PPS (320h)
Status	None	
Reference	<ul style="list-style-type: none"> <li>•1LSB of parameter value is equal to 0.1125 degree/s</li> <li>•The running time of Pan can calculate as under  <math display="block">\frac{(\text{Pan position after run}) - (\text{Pan position before run})}{(\text{Pan running speed})}</math>                     (refer to <b>12.27</b>, <b>12.29</b> concerning Pan position of pedestal)                      Example set Pan running speed 800. In this case, the running time is approx. 2 seconds from +800 position to -800 position of pedestal.  <math display="block">\frac{800\{\text{position} +90 \text{ degree}\} - (-800)\{\text{position} -90 \text{ degree}\}}{800\{\text{Pan running speed}\}}</math> </li> <li>•The command unable to set speed, is <b>Home Position, Pedestal Initialize 1</b> and <b>Pedestal Initialize 2</b>, total 3 commands.</li> <li>•Pan running speed can modify by this command during even running Pan.</li> </ul>	

● Format of Control Code

d0	d1	d2	d3	d4	d5	d6	d7	d8
Header	Device Num		Command		Parameter			End mark
FFh	30h	3Xh	00h	50h	p0	p1	p2	EFh

↓

The running speed indicates in 3 figures hexadecimal, and its ASCII code treats as parameter.		
Example:	150	⇒ 096h ⇒ p0 p1 p2 30h 39h 36h

● Answer Format

d0	d1	d2	d3	d4	d5
Header	Device Num		Error Code		End mark
FFh	30h	3Xh	e0	e1	EFh

↓

Error Flag indicates in 2 figures hexadecimal and returns ASCII code value.	
Example:	e0 e1
■ In case of No Error :	0000000B ⇒ 00h ⇒ 30h 30h
■ In case of Parameter Error :	0101000B ⇒ 50h ⇒ 35h 30h
■ In case of Mode Error :	1001000B ⇒ 90h ⇒ 39h 30h

● Condition of Error flag to be set

Parameter Error	<ul style="list-style-type: none"> <li>•Assigned parameter comes out less than minimum value.</li> <li>•Assigned parameter comes out more than maximum value.</li> </ul>
Mode Error	<ul style="list-style-type: none"> <li>•Not in status of <b>Camera ON</b>.</li> <li>•Not in status of <b>Host Control Mode</b>.</li> </ul>

## 12.2 Tilt Speed Assignment

## Pedestal Control Command Type 1

Function	To set the running speed of Tilt direction.	
Command	0051h	
Parameter	Length	3 byte
	Range	8~6222PPS (008h~26Eh)
	Default Value	622PPS (26Eh)
Status	None	
Reference	<ul style="list-style-type: none"> <li>•1LSB of parameter value is equal to 0.1125 degree/s</li> <li>•The running time of Tile can calculate as under  <math display="block">\frac{(\text{Tilt position after run}) - (\text{Tilt position before run})}{(\text{Tilt running speed})}</math>                     (refer to <b>12.28, 12.30</b> concerning Tilt position of pedestal)                      Example set Tilt running speed 600. In this case, the running time is approx. 0.9 seconds from +267 position to -267 position of pedestal.  <math display="block">\frac{267\{\text{position} +30 \text{ degree}\} - (-267)\{\text{position} -30 \text{ degree}\}}{600\{\text{Tilt running speed}\}}</math> </li> <li>•The command unable to set speed, is <b>Home Position, Pedestal Initialize 1</b> and <b>Pedestal Initialize 2</b>, total 3 commands.</li> <li>•Tilt running speed can modify by this command during even Tilt running.</li> </ul>	

### ● Format of Control Code

d0	d1	d2	d3	d4	d5	d6	d7	d8
Header	Device Num		Command		Parameter			End mark
FFh	30h	3Xh	00h	51h	p0	p1	p2	EFh

↓

The running speed indicates in 3 figures hexadecimal, and its ASCII code treats as parameter.		
Example:	350	⇒ 15Eh ⇒ p0 p1 p2 31h 35h 45h

### ● Answer Format

d0	d1	d2	d3	d4	d5
Header	Device Num		Error Code		End mark
FFh	30h	3Xh	e0	e1	EFh

↓

Error Flag indicates in 2 figures hexadecimal and returns ASCII code value.		
Example:		e0 e1
■ In case of No Error :	0000000B ⇒ 00h ⇒	30h 30h
■ In case of Parameter Error :	0101000B ⇒ 50h ⇒	35h 30h
■ In case of Mode Error :	1001000B ⇒ 90h ⇒	39h 30h

### ● Condition of Error flag to be set

Parameter Error	<ul style="list-style-type: none"> <li>•Assigned parameter comes out less than minimum value.</li> <li>•Assigned parameter comes out more than maximum value.</li> </ul>
Mode Error	<ul style="list-style-type: none"> <li>•Not in status of <b>Camera ON</b>.</li> <li>•Not in status of <b>Host Control Mode</b>.</li> </ul>

### 12.3 Pan Speed Request

Function	To request the running speed of Pan direction.	
Command	0052h	
Parameter	Length	1 byte
	Value	0h
Status	Length	3 byte
	Range	8~800 (008h~320h)
Reference	•1 LSB of status value is equal to 0.1125 degree/s.	

● Format of Control Code

	d0	d1	d2	d3	d4	d5	d6
Header	Device Num		Command		Parameter	End mark	
FFh	30h	3Xh	00h	52h	30h	EFh	

● Answer Format

■ In case of No Error

	d0	d1	d2	d3	d4	d5	d6	d7	d8
Header	Device Num		Error Code		Status			End mark	
FEh	30h	3Xh	30h	30h	s0	s1	s2	EFh	



The running speed indicates in 3 figures hexadecimal, and its ASCII code treats as status.

Example:

150	⇒	096h	⇒	s0	s1	s2
				30h	39h	36h

■ In case of Error

	d0	d1	d2	d3	d4	d5
Header	Device Num		Error Code		End mark	
FEh	30h	3Xh	e0	e1	EFh	



Error Flag indicates in 2 figures hexadecimal and returns ASCII code value.

Example:

				e0	e1
■ In case of Parameter Error :	01010000B	⇒	50h	⇒	35h 30h
■ In case of Mode Error :	10010000B	⇒	90h	⇒	39h 30h

● Condition of Error flag to be set

Parameter Error	•Assign illegal parameters.
Mode Error	•Not in status of <b>Camera ON</b> . •Not in status of <b>Host Control Mode</b> .

## 12.4 Tilt Speed Request

Pedestal Control Command Type 1

Function	To request the running speed of Tilt direction.	
Command	0052h	
Parameter	Length	1 byte
	Value	1h
Status	Length	3 byte
	Range	8~622 (008h~26Eh)
Reference	•1 LSB of status value is equal to 0.1125 degree/s.	

### ● Format of Control Code

d0	d1	d2	d3	d4	d5	d6
Header	Device Num		Command		Parameter	End mark
FFh	30h	3Xh	00h	52h	31h	EFh

### ● Answer Format

#### ■ In case of No Error

d0	d1	d2	d3	d4	d5	d6	d7	d8
Header	Device Num		Error Code		Status			End mark
FEh	30h	3Xh	30h	30h	s0	s1	s2	EFh

↓

The running speed indicates in 3 figures hexadecimal, and its ASCII code treats as status.		
Example:	350	⇒ 15Eh ⇒ s0 s1 s2 31h 35h 45h

#### ■ In case of Error

d0	d1	d2	d3	d4	d5
Header	Device Num		Error Code		End mark
FEh	30h	3Xh	e0	e1	EFh

↓

Error Flag indicates in 2 figures hexadecimal and returns ASCII code value.		
Example:		e0 e1
■ In case of Parameter Error :	01010000B ⇒ 50h	⇒ 35h 30h
■ In case of Mode Error :	10010000B ⇒ 90h	⇒ 39h 30h

### ● Condition of Error flag to be set

Parameter Error	•Assign illegal parameters.
Mode Error	•Not in status of <b>Camera ON</b> . •Not in status of <b>Host Control Mode</b> .

## 12.5 Pan Tilt Stop

Pedestal control Command Type 1

Function	To stop the running of Pan/Tilt.	
Command	0053h	
Parameter	Length	1 byte
	Value	0h
Status	None	
Reference	<ul style="list-style-type: none"> <li>•To stop the running of Pan/Tilt except the running by <b>Pedestal Initialize 1</b> and <b>Pedestal Initialize 2</b> commands.</li> <li>•By issuing this command, the <b>Panning</b> flag and <b>Tilting</b> flag to clear.</li> <li>•By issuing this command, the <b>Command Termination Notification</b> flag to clear.</li> </ul>	

### ● Format of Control Code

d0	d1	d2	d3	d4	d5	d6
Header	Device Num		Command		Parameter	End mark
FFh	30h	3Xh	00h	53h	30h	EFh

### ● Answer Format

d0	d1	d2	d3	d4	d5
Header	Device Num		Error Code		End mark
EFh	30h	3Xh	e0	e1	EFh

↓

Error Flag indicates in 2 figures hexadecimal and returns ASCII code value.	
Example:	e0 e1
■ In case of No Error :	0000000B ⇒ 00h ⇒ 30h 30h
■ In case of Busy :	00010000B ⇒ 10h ⇒ 31h 30h
■ In case of Parameter Error :	01010000B ⇒ 50h ⇒ 35h 30h
■ In case of Mode Error :	10010000B ⇒ 90h ⇒ 39h 30h

### ● Condition of Error flag to be set

Busy	•In case of executing <b>Pedestal Initialize 1</b> and <b>Pedestal Initialize 2</b> commands.
Parameter Error	•Assign illegal parameters.
Mode Error	<ul style="list-style-type: none"> <li>•Not in status of <b>Camera ON</b>.</li> <li>•Not in status of <b>Host Control Mode</b>.</li> </ul>

## 12.6 Pan Right Start

## Pedestal Control Command Type 2

Function	To start Pan running to the right.	
Command	0053h	
Parameter	Length	1 byte
	Value	1h
Status	None	
Reference	<ul style="list-style-type: none"> <li>•Until <b>Pan Tilt Stop</b> command issues, or right limit position, continue to run.</li> <li>•The running speed is able to set by <b>Pan Speed Assignment</b> command.</li> <li>•By issuing this command, 1 is set in <b>Panning</b> flag among the operating status. The setting flag will be done, just before running pedestal. When pedestal reaches to the right limit, Pan running will stop and clear <b>Panning</b> flag and 1 of <b>Pan Limit Position</b> flag will be set.</li> </ul> <p>Note: After power ON, at the moment of receipt of this command without executing <b>Pedestal Initialize 1</b> or <b>Pedestal Initialize 2</b>, returns mode error and executes <b>Pedestal Initialize 2</b>.</p>	

### ● Format of Control Code

d0	d1	d2	d3	d4	d5	d6
Header	Device Num		Command		Parameter	End mark
FFh	30h	3Xh	00h	53h	31h	EFh

### ● Answer Format

d0	d1	d2	d3	d4	d5
Header	Device Num		Error Code		End mark
EFh	30h	3Xh	e0	e1	EFh



Error Flag indicates in 2 figures hexadecimal and returns ASCII code value.		
Example:		e0 e1
■ In case of No Error :	0000000B ⇒ 00h ⇒	30h 30h
■ In case of Busy :	0001000B ⇒ 10h ⇒	31h 30h
■ In case of Parameter Error :	0101000B ⇒ 50h ⇒	35h 30h
■ In case of Mode Error :	1001000B ⇒ 90h ⇒	39h 30h

### ● Condition of Error flag to be set

Busy	<ul style="list-style-type: none"> <li>•In case of executing <b>Home Position</b>, <b>Pedestal Initialize 1</b> and <b>Pedestal Initialize 2</b> commands.</li> <li>•In case of executing <b>Pan/Tilt Angle Assignment</b> and <b>Preset Move</b> commands.</li> <li>•Executing Pan running by <b>Pedestal Control</b> command.</li> </ul>
Parameter Error	•Assign illegal parameters.
Mode Error	<ul style="list-style-type: none"> <li>•After power ON, not executed pedestal initialize.</li> <li>•Not in status of <b>Camera ON</b>.</li> <li>•Not in status of <b>Host Control Mode</b>.</li> </ul>

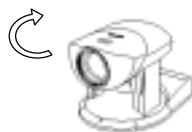

Normal Mounting: Right direction      Inverse Mounting: Right direction

## 12.7 Pan Left Start

## Pedestal Control Command Type 2

Function	To start Pan running to the left.	
Command	0053h	
Parameter	Length	1 byte
	Value	2h
Status	None	
Reference	<ul style="list-style-type: none"> <li>•Until <b>Pan/Tilt Stop</b> command issues, or reaches to the left limit, continue to run.</li> <li>•The running speed is able to set by <b>Pan Speed Assignment</b> command.</li> <li>•By issuing this command, 1 is set in Pan running flag among the running status. The setting flag will be done, just before running pedestal. When pedestal reaches to the left limit, Pan running will stop and clear <b>Pan running</b> flag and 1 of <b>Pan Limit Position</b> will be set.</li> </ul> <p>Note: After power ON, at the moment of receipt of this command without executing <b>Pedestal Initialize 1</b> or <b>Pedestal Initialize 2</b>, returns mode error and executes <b>Pedestal Initialize 2</b>.</p>	

### ● Format of Control Code

d0	d1	d2	d3	d4	d5	d6
Header	Device Num		Command		Parameter	End mark
FFh	30h	3Xh	00h	53h	32h	EFh

### ● Answer Format

d0	d1	d2	d3	d4	d5
Header	Device Num		Error Code		End mark
EFh	30h	3Xh	e0	e1	EFh



Error Flag indicates in 2 figures hexadecimal and returns ASCII code value.		
Example:		e0 e1
■ In case of No Error :	00000000B ⇒ 00h ⇒	30h 30h
■ In case of Busy :	00010000B ⇒ 10h ⇒	31h 30h
■ In case of Parameter Error :	01010000B ⇒ 50h ⇒	35h 30h
■ In case of Mode Error :	10010000B ⇒ 90h ⇒	39h 30h

### ● Condition of Error flag to be set

Busy	<ul style="list-style-type: none"> <li>•In case of executing <b>Home Position</b>, <b>Pedestal Initialize 1</b> and <b>Pedestal Initialize 2</b> commands.</li> <li>•In case of executing <b>Pan/Tilt Angle Assignment</b> and <b>Preset Move</b> commands.</li> <li>•Executing Pan running by <b>Pedestal Control</b> command.</li> </ul>
Parameter Error	•Assign illegal parameters.
Mode Error	<ul style="list-style-type: none"> <li>•After turn ON, pedestal initialize has never been done.</li> <li>•Not in status of <b>Camera ON</b>.</li> <li>•Not in status of <b>Host Control Mode</b>.</li> </ul>



Normal Mounting: Left direction



Inverse Mounting: Left direction



## 12.8 Tilt Up Start

## Pedestal Control Command Type 2

Function	To start Tilt running to the up.	
Command	0053h	
Parameter	Length	1 byte
	Value	3h
Status	None	
Reference	<ul style="list-style-type: none"> <li>•Until <b>Pan/Tilt Stop</b> command issues, or reaches to the upper limit, continue to run.</li> <li>•The running speed is able to set by <b>Tilt Speed Assignment</b> command.</li> <li>•By issuing this command, 1 is set in Tilt running flag among the running status. The setting flag will be done, just before running pedestal. When pedestal reaches to the upper limit, Tilt running will stop and clear <b>Tilt Running</b> flag and 1 of <b>Tilt Limit Position</b> will be set.</li> </ul> <p>Note: After power ON, at the moment of receipt of this command without executing <b>Pedestal Initialize 1</b> or <b>Pedestal Initialize 2</b>, returns mode error and executes <b>Pedestal Initialize 2</b>.</p>	

### ● Format of Control Code

d0	d1	d2	d3	d4	d5	d6
Header	Device Num		Command		Parameter	End mark
FFh	30h	3Xh	00h	53h	33h	EFh

### ● Answer Format

d0	d1	d2	d3	d4	d5
Header	Device Num		Error Code		End mark
EFh	30h	3Xh	e0	e1	EFh



Error Flag indicates in 2 figures hexadecimal and returns ASCII code value.	
Example:	e0 e1
■ In case of No Error :	00000000B ⇒ 00h ⇒ 30h 30h
■ In case of Busy :	00010000B ⇒ 10h ⇒ 31h 30h
■ In case of Parameter Error :	01010000B ⇒ 50h ⇒ 35h 30h
■ In case of Mode Error :	10010000B ⇒ 90h ⇒ 39h 30h

### ● Condition of Error flag to be set

Busy	<ul style="list-style-type: none"> <li>•In case of executing <b>Home Position, Pedestal Initialize 1</b> and <b>Pedestal Initialize 2</b> commands.</li> <li>•In case of executing <b>Pan/Tilt Angle Assignment</b> and <b>Preset Move</b> commands.</li> <li>•Executing Tilt running by <b>Pedestal Control</b> command.</li> </ul>
Parameter Error	•Assign illegal parameters.
Mode Error	<ul style="list-style-type: none"> <li>•After turn ON, Pedestal Initialize has never been done.</li> <li>•Not in status of <b>Camera ON</b>.</li> <li>•Not in status of <b>Host Control Mode</b>.</li> </ul>

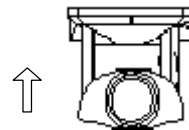
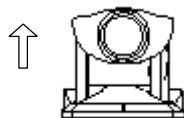

Normal Mounting: Up direction

Inverse Mounting: Up direction

## 12.9 Tilt Down Start

## Pedestal Control Command Type 2

Function	To start Tilt running to the down.	
Command	0053h	
Parameter	Length	1 byte
	Value	4h
Status	None	
Reference	<ul style="list-style-type: none"> <li>•Until <b>Pan/Tilt Stop</b> command issues, or reaches to the lower limit, continue to run.</li> <li>•The running speed is able to set by <b>Tilt Speed Assignment</b> command.</li> <li>•By issuing this command, 1 is set in <b>Tilt Running</b> flag among the running status. The setting flag will be done, just before running pedestal. When pedestal reaches to the low limit, Tilt running will stop and clear <b>Tilt Running</b> flag and 1 of <b>Tilt Limit Position</b> will be set.</li> </ul> <p>Note: After power ON, at the moment of receipt of this command without executing <b>Pedestal Initialize 1</b> or <b>Pedestal Initialize 2</b>, returns mode error and executes <b>Pedestal Initialize 2</b>.</p>	

### ● Format of Control Code

d0	d1	d2	d3	d4	d5	d6
Header	Device Num		Command		Parameter	End mark
FFh	30h	3Xh	00h	53h	33h	EFh

### ● Answer Format

d0	d1	d2	d3	d4	d5
Header	Device Num		Error Code		End mark
EFh	30h	3Xh	e0	e1	EFh



Error Flag indicates in 2 figures hexadecimal and returns ASCII code value.	
Example:	e0 e1
■ In case of No Error :	00000000B ⇒ 00h ⇒ 30h 30h
■ In case of Busy :	00010000B ⇒ 10h ⇒ 31h 30h
■ In case of Parameter Error :	01010000B ⇒ 50h ⇒ 35h 30h
■ In case of Mode Error :	10010000B ⇒ 90h ⇒ 39h 30h

### ● Condition of Error flag to be set

Busy	<ul style="list-style-type: none"> <li>•In case of executing <b>Home Position</b>, <b>Pedestal Initialize 1</b> and <b>Pedestal Initialize 2</b> commands.</li> <li>•In case of executing <b>Pan/Tilt Angle Assignment</b> and <b>Preset Move</b> commands.</li> <li>•Executing Tilt running by <b>Pedestal Control</b> command.</li> </ul>
Parameter Error	•Assign illegal parameters.
Mode Error	<ul style="list-style-type: none"> <li>•After turn ON, pedestal initialize has never been done.</li> <li>•Not in status of <b>Camera ON</b>.</li> <li>•Not in status of <b>Host Control Mode</b>.</li> </ul>

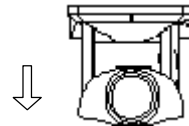

Normal Mounting: Down direction

Inverse mounting: Down direction

## 12.10 Home Position

## Pedestal Control Command Type 2

Function	To move home position (front).
Command	0057h
Parameter	None
Status	None
Reference	<ul style="list-style-type: none"> <li>•Home position (front) is originally set at the following position.            Angle of Pan direction (position)                    0 (8000h)            Angle of Tilt direction (position)                    0 (8000h)</li> <li>•Regardless of the running speed setting of Pan/Tilt direction, Pan/Tilt will return to home position with the fastest speed.</li> <li>•After power ON, at the moment of receipt of this command without executing <b>Pedestal Initialize 1</b> or <b>Pedestal Initialize 2</b>, execute <b>Pedestal Initialize 1</b>.</li> <li>•In process of home position running, <b>Pan/Tilt Stop</b> command is effective.</li> <li>•By issuing this command, Pan &amp; Tilt run simultaneously and flags of <b>Pan &amp; Tilt Running</b> among of running status, come out 1. When Pan running stops flag of Pan running comes out 0, then Tilt will stop and the flag of Tilt comes out zero.</li> </ul> <p>Note:            In case that Pan &amp; Tilt are in home position, Pan &amp; Tilt do not run.</p>

### ● Format of Control Code

d0	d1	d2	d3	d4	d5
Header	Device Num		Command		End mark
FFh	30h	3Xh	00h	57h	EFh

### ● Answer Format

d0	d1	d2	d3	d4	d5
Header	Device Num		Error Code		End mark
FEh	30h	3Xh	e0	e1	EFh

↓d

Error Flag indicates in 2 figures hexadecimal and returns ASCII code value.	
Example:	e0 e1
■ In case of No Error :	00000000B ⇒ 00h ⇒ 30h 30h
■ In case of Busy :	00010000B ⇒ 10h ⇒ 31h 30h
■ In case of Mode Error :	10010000B ⇒ 90h ⇒ 39h 30h

### ● Condition of Error flag to be set

Busy	<ul style="list-style-type: none"> <li>•In case of executing <b>Pedestal Initialize 1</b> and <b>Pedestal Initialize 2</b> commands.</li> <li>•In case of executing <b>Pan/Tilt Angle Assignment</b> and <b>Preset Move</b> commands.</li> <li>•Executing Pan/Tilt running by <b>Pedestal Control</b> command.</li> </ul>
Mode Error	<ul style="list-style-type: none"> <li>•Not in status of <b>Camera ON</b>.</li> <li>•Not in status of <b>Host Control Mode</b>.</li> </ul>

## 12.11 Pedestal Initialize 1

## Pedestal Control Command Type 2

Function	After initialize pedestal, to run to home position.	
Command	0058h	
Parameter	Length	1 byte
	Value	0h
Status	None	
Reference	<ul style="list-style-type: none"> <li>•After initialization, run to home position.</li> <li>•Home Position (Front) is originally set at the following position. <ul style="list-style-type: none"> <li>Angle of Pan direction (position) 0 (8000h)</li> <li>Angle of Tilt direction (position) 0 (8000h)</li> </ul> </li> <li>•By issuing this command, at first to centralize with high speed, then approach to the right central position with low speed and determine the central position. This central position will be home position.</li> </ul> <p>The flag of Pan &amp; Tilt running during <b>Pan &amp; Tilt Running</b> come out 1 and when every operation stops, it comes out zero.</p>	

### ● Format of Control Code

d0	d1	d2	d3	d4	d5	d6
Header	Device Num		Command		Parameter	End mark
FFh	30h	3Xh	00h	58h	30h	EFh

### ● Answer Format

d0	d1	d2	d3	d4	d5
Header	Device Num		Error Code		End mark
FEh	30h	3Xh	e0	e1	EFh



Error Flag indicates in 2 figures hexadecimal and returns ASCII code value.	
Example:	e0 e1
■ In case of No Error :	0000000B ⇒ 00h ⇒ 30h 30h
■ In case of Busy :	00010000B ⇒ 10h ⇒ 31h 30h
■ In case of Parameter Error :	01010000B ⇒ 50h ⇒ 35h 30h
■ In case of Mode Error :	10010000B ⇒ 90h ⇒ 39h 30h

### ● Condition of Error flag to be set

Busy	<ul style="list-style-type: none"> <li>•In case of executing Pan running by <b>Pedestal Control</b> command.</li> <li>•In case of executing Tilt running by <b>Pedestal Control</b> command.</li> <li>•In case of executing <b>Preset Move</b> command.</li> </ul>
Parameter Error	•Assign illegal parameters.
Mode Error	<ul style="list-style-type: none"> <li>•Not in status of <b>Camera ON</b>.</li> <li>•Not in status of <b>Host Control Mode</b>.</li> </ul>

## 12.12 Pedestal Initialize 2

## Pedestal Control Command Type 2

Function	After initialize pedestal, to run to original position.	
Command	0058h	
Parameter	Length	1 byte
	Value	1h
Status	None	
Reference	<ul style="list-style-type: none"> <li>•After initialization, runs to former position.</li> <li>•By issuing this command, at first to centralize in Pan with high speed, then approaches to Pan central position with low speed and determine Pan central position and secondly to try to centralize in Tilt with high speed, then approach to Tilt central position with low speed and determines Pan &amp; Tilt central position. This Pan &amp; Tilt central position will be home position and returns to the position, when this command issued.</li> </ul> <p>The flag of <b>Pan &amp; Tilt Running</b> during <b>Pan &amp; Tilt Running</b> comes out 1 and when every operation stops, it comes out zero.</p>	

### ● Format of Control Code

d0	d1	d2	d3	d4	d5	d6
Header	Device Num		Command		Parameter	End mark
FFh	30h	3Xh	00h	58h	31h	EFh

### ● Answer Format

d0	d1	d2	d3	d4	d5
Header	Device Num		Error Code		End mark
FEh	30h	3Xh	e0	e1	EFh



Error Flag indicates in 2 figures hexadecimal and returns ASCII code value.	
Example:	e0 e1
■ In case of No Error :	00000000B ⇒ 00h ⇒ 30h 30h
■ In case of Busy :	00010000B ⇒ 10h ⇒ 31h 30h
■ In case of Parameter Error :	01010000B ⇒ 50h ⇒ 35h 30h
■ In case of Mode Error :	10010000B ⇒ 90h ⇒ 39h 30h

### ● Condition of Error flag to be set

Busy	<ul style="list-style-type: none"> <li>•In case of executing Pan running by <b>Pedestal Control</b> command.</li> <li>•In case of executing Tilt running by <b>Pedestal Control</b> command.</li> <li>•In case of executing <b>Preset Move</b> command.</li> </ul>
Parameter Error	•Assign illegal parameters.
Mode Error	<ul style="list-style-type: none"> <li>•Not in status of <b>Camera ON</b>.</li> <li>•Not in status of <b>Host Control Mode</b>.</li> </ul>

### 12.13 Pan Slowest Speed Request

Pedestal Control Command Type 1

Function	To return the slowest running speed in Pan direction.	
Command	0059h	
Parameter	Length	1 byte
	Value	0h
Status	Length	3 byte
	Value	8 (008h)
Reference	<ul style="list-style-type: none"> <li>•To return the slowest speed enable to set the running speed of Pan direction.</li> <li>•The status value 8 is equal to approx. 0.9 degree/s.</li> </ul>	

● Format of Control Code

d0	d1	d2	d3	d4	d5	d6
Header	Device Num		Command		Parameter	End mark
FFh	30h	3Xh	00h	59h	30h	EFh

● Answer Format

■ In case of No Error

d0	d1	d2	d3	d4	d5	d6	d7	d8
Header	Device Num		Error Code		Status			End mark
FEh	30h	3Xh	30h	30h	30h	30h	38h	EFh

■ In case of Error

d0	d1	d2	d3	d4	d5
Header	Device Num		Error Code		End mark
FEh	30h	3Xh	e0	e1	EFh



Error Flag indicates in 2 figures hexadecimal and returns ASCII code value.		
Example:		e0 e1
■ In case of Parameter Error :	01010000B ⇒ 50h ⇒	35h 30h
■ In case of Mode Error :	10010000B ⇒ 90h ⇒	39h 30h

● Condition of Error flag to be set

Parameter Error	•Assign illegal parameters.
Mode Error	<ul style="list-style-type: none"> <li>•Not in status of <b>Camera ON..</b></li> <li>•Not in status of <b>Host Control Mode.</b></li> </ul>

## 12.14 Pan Fastest Speed Request

Pedestal Control Command Type 1

Function	To return the fastest running speed in Pan direction.	
Command	0059h	
Parameter	Length	1 byte
	Value	1h
Status	Length	3 byte
	Value	800 (320h)
Reference	<ul style="list-style-type: none"> <li>•To return the fastest speed enable to set the running speed of Pan direction.</li> <li>•The status value 800 is equal to approx. 90 degrees/s.</li> </ul>	

### ● Format of Control Code

d0	d1	d2	d3	d4	d5	d6
Header	Device Num		Command		Parameter	End mark
FFh	30h	3Xh	00h	59h	31h	EFh

### ● Answer Format

#### ■ In case of No Error

d0	d1	d2	d3	d4	d5	d6	d7	d8
Header	Device Num		Error Code		Status			End mark
FEh	30h	3Xh	30h	30h	33h	32h	30h	EFh

#### ■ In case of Error

d0	d1	d2	d3	d4	d5
Header	Device Num		Error Code		End mark
FEh	30h	3Xh	e0	e1	EFh



Error Flag indicates in 2 figures hexadecimal and returns ASCII code value.	
Example:	e0 e1
■ In case of Parameter Error :	01010000B ⇒ 50h ⇒ 35h 30h
■ In case of Mode Error :	10010000B ⇒ 90h ⇒ 39h 30h

### ● Condition of Error flag to be set

Parameter Error	•Assign illegal parameters.
Mode Error	<ul style="list-style-type: none"> <li>•Not in status of <b>Camera ON</b>.</li> <li>•Not in status of <b>Host Control Mode</b>.</li> </ul>

## 12.15 Tilt Slowest Speed Request

Pedestal Control Command Type 1

Function	To return the slowest running speed in Tilt direction.	
Command	0059h	
Parameter	Length	1 byte
	Value	2h
Status	Length	3 byte
	Value	8 (008h)
Reference	<ul style="list-style-type: none"> <li>•To return the slowest speed enable to set the running speed of Tilt direction.</li> <li>•The status value 8 is equal to approx. 0.9 degree/s.</li> </ul>	

### ● Format of Control Code

d0	d1	d2	d3	d4	d5	d6
Header	Device Num		Command		Parameter	End mark
FFh	30h	3Xh	00h	59h	32h	EFh

### ● Answer Format

#### ■ In case of No Error

d0	d1	d2	d3	d4	d5	d6	d7	d8
Header	Device Num		Error Code		Status			End mark
FEh	30h	3Xh	30h	30h	30h	30h	38h	EFh

#### ■ In case of Error

d0	d1	d2	d3	d4	d5
Header	Device Num		Error Code		End mark
FEh	30h	3Xh	e0	e1	EFh



Error Flag indicates in 2 figures hexadecimal and returns ASCII code value.		
Example:		e0 e1
■ In case of Parameter Error :	01010000B ⇒ 50h ⇒	35h 30h
■ In case of Mode Error :	10010000B ⇒ 90h ⇒	39h 30h

### ● Condition of Error flag to be set

Parameter Error	•Assign illegal parameters.
Mode Error	<ul style="list-style-type: none"> <li>•Not in status of <b>Camera ON</b>.</li> <li>•Not in status of <b>Host Control Mode</b>.</li> </ul>



## 12.16 Tilt Fastest Speed Request

Pedestal Control Command Type 1

Function	To return the fastest running speed in Tilt direction.	
Command	0059h	
Parameter	Length	1 byte
	Value	3h
Status	Length	3 byte
	Value	622 (26Eh)
Reference	<ul style="list-style-type: none"> <li>•To return the fastest speed enable to set the running speed of Tilt direction.</li> <li>•The status value 622 is equal to approx. 70 degrees/s.</li> </ul>	

### ● Format of Control Code

	d0	d1	d2	d3	d4	d5	d6
Header	Device Num		Command		Parameter	End mark	
FFh	30h	3Xh	00h	59h	33h	EFh	

### ● Answer Format

#### ■ In case of No Error

	d0	d1	d2	d3	d4	d5	d6	d7	d8
Header	Device Num		Error Code		Status			End mark	
FEh	30h	3Xh	30h	30h	32h	36h	45h	EFh	

#### ■ In case of Error

	d0	d1	d2	d3	d4	d5
Header	Device Num		Error Code		End mark	
FEh	30h	3Xh	e0	e1	EFh	



Error Flag indicates in 2 figures hexadecimal and returns ASCII code value.		
Example:		e0 e1
■ In case of Parameter Error :	01010000B ⇒ 50h ⇒	35h 30h
■ In case of Mode Error :	10010000B ⇒ 90h ⇒	39h 30h

### ● Condition of Error flag to be set

Parameter Error	•Assign illegal parameters.
Mode Error	<ul style="list-style-type: none"> <li>•Not in status of <b>Camera ON</b>.</li> <li>•Not in status of <b>Host Control Mode</b>.</li> </ul>

### 12.17 Pan Angle Pulse Ratio Request

Pedestal Control Command Type 1

Function	To return the coefficient to convert parameter value using <b>Pan angle</b> (position) and <b>Pan speed</b> commands to angle unit.	
Command	005Bh	
Parameter	Length	1 byte
	Value	0h
Status	Length	4 byte
	Value	11250 (2BF2h)
Reference	<p>•To return integral value multiplied 100000 to the conversion coefficient of true Pan angle. In case of angle conversion, divide it by 100000. Example below, Status value /100000 = 11250 /100000 = 0.1125</p> <p>Note: The parameter of <b>12.1 Pan Speed Assignment</b> command can be converted as under. Pan speed = 800PPS = 800 × 0.1125 = 90 degrees/s</p>	

● Format of Control Code

d0	d1	d2	d3	d4	d5	d6
Header	Device Num		Command		Parameter	End mark
FFh	30h	3Xh	00h	5Bh	30h	EFh

● Answer Format

■ In case of No Error

d0	d1	d2	d3	d4	d5	d6	d7	d8	d9
Header	Device Num		Error Code		Status				End mark
FEh	30h	3Xh	30h	30h	32h	42h	46h	32h	EFh

■ In case of Error

d0	d1	d2	d3	d4	d5
Header	Device Num		Error Code		End mark
FEh	30h	3Xh	e0	e1	EFh



Error Flag indicates in 2 figures hexadecimal and returns ASCII code value.		
Example:		e0 e1
■ In case of Parameter Error :	01010000B ⇒ 50h ⇒	35h 30h
■ In case of Mode Error :	10010000B ⇒ 90h ⇒	39h 30h

● Condition of Error flag to be set

Parameter Error	•Assign illegal parameters.
Mode Error	•Not in status of <b>Camera ON</b> . •Not in status of <b>Host Control Mode</b> .

## 12.18 Tilt Angle Pulse Ratio Request

Pedestal Control Command Type 1

Function	To return the coefficient to convert parameter value using <b>Tilt angle</b> (position) and <b>Tilt speed</b> commands to angle unit.	
Command	005Bh	
Parameter	Length	1 byte
	Value	1h
Status	Length	4 byte
	Value	11250 (2BF2h)
Reference	<p>•To return integral value multiplied 100000 to the conversion coefficient of true Tilt angle. In case of angle conversion, divide it by 100000. Example below, Status value /100000 = 11250 /100000 = 0.1125</p> <p>Note: The parameter of <b>12.2 Tilt Speed Assignment</b> command can be converted as under. Tilt speed = 622 PPS = <math>622 \times 0.1125 \approx 70</math> degrees/s</p>	

### ● Format of Control Code

d0	d1	d2	d3	d4	d5	d6
Header	Device Num		Command		Parameter	End mark
FFh	30h	3Xh	00h	5Bh	31h	EFh

### ● Answer Format

#### ■ In case of No Error

d0	d1	d2	d3	d4	d5	d6	d7	d8	d9
Header	Device Num		Error Code		Status				End mark
FEh	30h	3Xh	30h	30h	32h	42h	46h	32h	EFh

#### ■ In case of Error

d0	d1	d2	d3	d4	d5
Header	Device Num		Error Code		End mark
FEh	30h	3Xh	e0	e1	EFh



Error Flag indicates in 2 figures hexadecimal and returns ASCII code value.		
Example:		e0 e1
■ In case of Parameter Error :	01010000B ⇒ 50h ⇒	35h 30h
■ In case of Mode Error :	10010000B ⇒ 90h ⇒	39h 30h

### ● Condition of Error flag to be set

Parameter Error	•Assign illegal parameters.
Mode Error	•Not in status of <b>Camera ON</b> . •Not in status of <b>Host Control Mode</b> .

## 12.19 Pan Minimum Angle Request

Pedestal Control Command Type 1

Function	To return the minimum value (left) in Pan direction.	
Command	005Ch	
Parameter	Length	1 byte
	Value	0h
Status	Length	4 byte
	Value	Normal Mounting: -889 (7C87h) Inverse Mounting: -1511 (7A19h)
Reference	<ul style="list-style-type: none"> <li>•Status Value (-889) in normal mounting is the position rotated approx. 100 degree to left as zero degree for front.</li> <li>•Status Value (-1511) in inverse mounting is the position rotated approx. 170 degrees to left as zero degree for front.</li> </ul>	

### ● Format of Control Code

d0	d1	d2	d3	d4	d5	d6
Header	Device Num		Command		Parameter	End mark
FFh	30h	3Xh	00h	5Ch	30h	EFh

### ● Answer Format

#### ■ In case of No Error

d0	d1	d2	d3	d4	d5	d6	d7	d8	d9
Header	Device Num		Error Code		Status				End mark
FEh	30h	3Xh	30h	30h	37h	43h	38h	37h	EFh

or

d0	d1	d2	d3	d4	d5	d6	d7	d8	d9
Header	Device Num		Error Code		Status				End mark
FEh	30h	3Xh	30h	30h	37h	41h	31h	39h	EFh

#### ■ In case of Error

d0	d1	d2	d3	d4	d5
Header	Device Num		Error Code		End mark
FEh	30h	3Xh	e0	e1	EFh

↓

Error Flag indicates in 2 figures hexadecimal and returns ASCII code value.	
Example:	e0 e1
■ In case of Parameter Error :	01010000B ⇒ 50h ⇒ 35h 30h
■ In case of Mode Error :	10010000B ⇒ 90h ⇒ 39h 30h

### ● Condition of Error flag to be set

Parameter Error	•Assign illegal parameters.
Mode Error	•Not in status of <b>Camera ON</b> . •Not in status of <b>Host Control Mode</b> .

## 12.20 Pan Maximum Angle Request

Pedestal Control Command Type 1

Function	To return the maximum value (right) in Pan direction.	
Command	005Ch	
Parameter	Length	1 byte
	Value	1h
Status	Length	4 byte
	Value	Normal Mounting: +889 (8379h) Inverse Mounting: +1511 (85E7h)
Reference	<ul style="list-style-type: none"> <li>•Status Value (+889) in normal mounting is the position rotated approx. 100 degree to right as zero degree for front.</li> <li>•Status Value (+1511) in inverse mounting is the position rotated approx. 170 degrees to right as zero degree for front.</li> </ul>	

### ● Format of Control Code

d0	d1	d2	d3	d4	d5	d6
Header	Device Num		Command		Parameter	End mark
FFh	30h	3Xh	00h	5Ch	31h	EFh

### ● Answer Format

#### ■ In case of No Error

d0	d1	d2	d3	d4	d5	d6	d7	d8	d9
Header	Device Num		Error Code		Status				End mark
FEh	30h	3Xh	30h	30h	38h	33h	37h	39h	EFh

or

d0	d1	d2	d3	d4	d5	d6	d7	d8	d9
Header	Device Num		Error Code		Status				End mark
FEh	30h	3Xh	30h	30h	38h	35h	46h	37h	EFh

#### ■ In case of Error

d0	d1	d2	d3	d4	d5
Header	Device Num		Error Code		End mark
FEh	30h	3Xh	e0	e1	EFh

↓

Error Flag indicates in 2 figures hexadecimal and returns ASCII code value.	
Example:	e0 e1
■ In case of Parameter Error :	01010000B ⇒ 50h ⇒ 35h 30h
■ In case of Mode Error :	10010000B ⇒ 90h ⇒ 39h 30h

### ● Condition of Error flag to be set

Parameter Error	•Assign illegal parameters.
Mode Error	•Not in status of <b>Camera ON</b> . •Not in status of <b>Host Control Mode</b> .

## 12.21 Tilt Minimum Angle Request

Pedestal Control Command Type 1

Function	To return the minimum value (down) in Tilt direction.	
Command	005Ch	
Parameter	Length	1 byte
	Value	2h
Status	Length	4 byte
	Value	Normal Mounting: -267 (7EF5h) Inverse Mounting: -800 (7CE0h)
Reference	<ul style="list-style-type: none"> <li>•Status Value (-267) in normal mounting is the position rotated approx. 30 degree to down as zero degree for horizontal.</li> <li>•Status Value (-800) in inverse mounting is the position rotated approx. 90 degrees to down as zero degree for horizontal.</li> </ul>	

### ● Format of Control Code

d0	d1	d2	d3	d4	d5	d6
Header	Device Num		Command		Parameter	End mark
FFh	30h	3Xh	00h	5Ch	32h	EFh

### ● Answer Format

#### ■ In case of No Error

d0	d1	d2	d3	d4	d5	d6	d7	d8	d9
Header	Device Num		Error Code		Status				End mark
FEh	30h	3Xh	30h	30h	37h	45h	46h	35h	EFh

or

d0	d1	d2	d3	d4	d5	d6	d7	d8	d9
Header	Device Num		Error Code		Status				End mark
FEh	30h	3Xh	30h	30h	37h	43h	45h	30h	EFh

#### ■ In case of Error

d0	d1	d2	d3	d4	d5
Header	Device Num		Error Code		End mark
FEh	30h	3Xh	e0	e1	EFh



Error Flag indicates in 2 figures hexadecimal and returns ASCII code value.	
Example:	e0 e1
■ In case of Parameter Error :	01010000B ⇒ 50h ⇒ 35h 30h
■ In case of Mode Error :	10010000B ⇒ 90h ⇒ 39h 30h

### ● Condition of Error flag to be set

Parameter Error	•Assign illegal parameters.
Mode Error	•Not in status of <b>Camera ON</b> . •Not in status of <b>Host Control Mode</b> .

## 12.22 Tilt Maximum Angle Request

Pedestal Control Command Type 1

Function	To return the maximum value (up) in Tilt direction.	
Command	005Ch	
Parameter	Length	1 byte
	Value	3h
Status	Length	4 byte
	Value	Normal Mounting: +800 (8320h) Inverse Mounting: +89 (8059h)
Reference	<ul style="list-style-type: none"> <li>•Status Value (+800) in normal mounting is the position rotated approx. 90 degrees to upper as zero degree for horizontal.</li> <li>•Status Value (+89) in inverse mounting is the position rotated approx. 10 degrees to upper as zero degree for horizontal.</li> </ul>	

### ● Format of Control Code

d0	d1	d2	d3	d4	d5	d6
Header	Device Num		Command		Parameter	End mark
FFh	30h	3Xh	00h	5Ch	33h	EFh

### ● Answer Format

#### ■ In case of No Error

d0	d1	d2	d3	d4	d5	d6	d7	d8	d9
Header	Device Num		Error Code		Status				End mark
FEh	30h	3Xh	30h	30h	38h	33h	32h	30h	EFh

or

d0	d1	d2	d3	d4	d5	d6	d7	d8	d9
Header	Device Num		Error Code		Status				End mark
FEh	30h	3Xh	30h	30h	38h	30h	35h	39h	EFh

#### ■ In case of Error

d0	d1	d2	d3	d4	d5
Header	Device Num		Error Code		End mark
FEh	30h	3Xh	e0	e1	EFh



Error Flag indicates in 2 figures hexadecimal and returns ASCII code value.	
Example:	e0 e1
■ In case of Parameter Error :	01010000B ⇒ 50h ⇒ 35h 30h
■ In case of Mode Error :	10010000B ⇒ 90h ⇒ 39h 30h

### ● Condition of Error flag to be set

Parameter Error	•Assign illegal parameters.
Mode Error	•Not in status of <b>Camera ON</b> . •Not in status of <b>Host Control Mode</b> .

## 12.23 Pan/Tilt Stop

Pedestal Control Command Type 1

Function	To stop motion of Pan & Tilt.	
Command	0060h	
Parameter	Length	2 byte
	Value	00h
Status	None	
Reference	<ul style="list-style-type: none"> <li>•To stop the motion of Pan/Tilt excluding the motion by <b>Pedestal Initialize 1 &amp; Pedestal Initialize 2</b>.</li> <li>•By issuing this command, flag in Pan/Tilt motion among of the executing status comes out zero.</li> <li>•By issuing this command, the requested flag of <b>Command Termination Notification</b> to Pan/Tilt motion comes out zero.</li> </ul>	

### ● The format of Control Code

d0	d1	d2	d3	d4	d5	d6	d7
Header	Device Num		Command		Parameter		End mark
FFh	30h	3Xh	00h	60h	30h	30h	EFh

### ● Answer Format

d0	d1	d2	d3	d4	d5
Header	Device Num		Error Code		End mark
FEh	30h	3Xh	e0	e1	EFh



Error Flag indicates in 2 figures hexadecimal and returns ASCII code value.	
Example:	e0 e1
■ In case of No Error :	00000000B ⇒ 00h ⇒ 30h 30h
■ In case of Busy :	00010000B ⇒ 10h ⇒ 31h 30h
■ In case of Parameter Error :	01010000B ⇒ 50h ⇒ 35h 30h
■ In case of Mode Error :	10010000B ⇒ 90h ⇒ 39h 30h

### ● Condition of Error flag to be set

Busy	•In case of executing <b>Pedestal Initialize 1</b> and <b>Pedestal Initialize 2</b> commands.
Parameter Error	•Assign illegal parameters.
Mode Error	<ul style="list-style-type: none"> <li>•Not in status of <b>Camera ON</b>.</li> <li>•Not in status of <b>Host Control Mode</b>.</li> </ul>



## 12.24 Pan/Tilt Start Stop

## Pedestal Control Command Type 2

Function	To start or stop the motion of Pan/Tilt.																															
Command	0060h																															
Parameter	Length	2 byte																														
	First Value	0h~2h																														
	Second Value	0h~2h																														
Status	None																															
Reference	<p>•First parameter assigns Pan motion, and second parameter assigns Tilt motion. Depend on the combination of first and second parameter, the following nine (9) kind of motion can be assigned.</p> <table border="0"> <thead> <tr> <th>First Parameter</th> <th>Second Parameter</th> <th>Pan/Tilt Motion</th> </tr> </thead> <tbody> <tr> <td>0h</td> <td>0h</td> <td>: Pan Stop, Tilt Stop</td> </tr> <tr> <td>0h</td> <td>1h</td> <td>: Pan Stop, Tilt Up Start</td> </tr> <tr> <td>0h</td> <td>2h</td> <td>: Pan Stop, Tilt Down Start</td> </tr> <tr> <td>1h</td> <td>0h</td> <td>: Pan Right Start, Tilt Stop</td> </tr> <tr> <td>1h</td> <td>1h</td> <td>: Pan Right Start, Tilt Up Start</td> </tr> <tr> <td>1h</td> <td>2h</td> <td>: Pan Right Start, Tilt Down Start</td> </tr> <tr> <td>2h</td> <td>0h</td> <td>: Pan Left Start, Tilt Stop</td> </tr> <tr> <td>2h</td> <td>1h</td> <td>: Pan Left Start, Tilt Up Start</td> </tr> <tr> <td>2h</td> <td>2h</td> <td>: Pan Left Start, Tilt Down Start</td> </tr> </tbody> </table> <p>•The stop motion of Pan (0h) is different from the one of Tilt (0). See <b>12.23 Pan/Tilt Stop</b>.</p> <p>•In case of changing motion status of Pan/Tilt by this command, not necessary to issue <b>Pan/Tilt Stop</b> command. For example, the status in Pan right start and Tilt up start can be changed to the status in Pan left start and Tilt down start.</p> <p>•<b>Pan/Tilt Speed Assignment</b> command is able to set <b>Pan/Tilt Running Speed</b>.</p> <p>•By issuing this command, Pan/Tilt will be simultaneously in action, and flag of Pan/Tilt in action, is to set 1. When Pan motion stops, flag of Pan in action clears it zero and When Tilt motion stops, flag of Tilt in action clear it zero.</p> <p>Note: After power on, in case of receipt of this command without executing <b>Pedestal Initialize 1</b> and <b>Pedestal Initialize 2</b>, mode error is returned and <b>Pedestal Initialize 2</b> will be executed.</p>		First Parameter	Second Parameter	Pan/Tilt Motion	0h	0h	: Pan Stop, Tilt Stop	0h	1h	: Pan Stop, Tilt Up Start	0h	2h	: Pan Stop, Tilt Down Start	1h	0h	: Pan Right Start, Tilt Stop	1h	1h	: Pan Right Start, Tilt Up Start	1h	2h	: Pan Right Start, Tilt Down Start	2h	0h	: Pan Left Start, Tilt Stop	2h	1h	: Pan Left Start, Tilt Up Start	2h	2h	: Pan Left Start, Tilt Down Start
First Parameter	Second Parameter	Pan/Tilt Motion																														
0h	0h	: Pan Stop, Tilt Stop																														
0h	1h	: Pan Stop, Tilt Up Start																														
0h	2h	: Pan Stop, Tilt Down Start																														
1h	0h	: Pan Right Start, Tilt Stop																														
1h	1h	: Pan Right Start, Tilt Up Start																														
1h	2h	: Pan Right Start, Tilt Down Start																														
2h	0h	: Pan Left Start, Tilt Stop																														
2h	1h	: Pan Left Start, Tilt Up Start																														
2h	2h	: Pan Left Start, Tilt Down Start																														

● Format of Control Code (Example: Pan Right Start, Tilt Down Start)

d0	d1	d2	d3	d4	d5	d6	d7
Header	Device Num		Command		Parameter		End mark
FFh	30h	3Xh	00h	60h	31h	32h	EFh

● Answer Format

d0	d1	d2	d3	d4	d5
Header	Device Num		Error Code		End mark
FEh	30h	3Xh	e0	e1	EFh



Error Flag indicates in 2 figures hexadecimal and returns ASCII code value.	
Example:	e0 e1
■ In case of No Error :	00000000B ⇒ 00h ⇒ 30h 30h
■ In case of Busy :	00010000B ⇒ 10h ⇒ 31h 30h
■ In case of Parameter Error :	01010000B ⇒ 50h ⇒ 35h 30h
■ In case of Mode Error :	10010000B ⇒ 90h ⇒ 39h 30h

● Condition of Error flag to be set

Busy	<ul style="list-style-type: none"> <li>•In case of executing <b>Home Position, Pedestal Initialize 1</b> and <b>Pedestal Initialize 2</b> commands.</li> <li>•In case of executing <b>Pan/Tilt Angle Assignment</b> and <b>Preset Move</b> commands.</li> <li>•Executing Pan/Tilt running by <b>Pedestal Control</b> command.</li> </ul>
Parameter Error	<ul style="list-style-type: none"> <li>•Assign illegal parameters.</li> </ul>
Mode Error	<ul style="list-style-type: none"> <li>•After Power ON, Not executed Pedestal Initialize.</li> <li>•Not in status of <b>Camera ON</b>.</li> <li>•Not in status of <b>Host Control Mode</b>.</li> </ul>

## 12.25 Pan/Tilt Angle Assignment

## Pedestal Control Command Type 2

Function	To assign angle (position) in Pan/Tilt direction																													
Command	0062h																													
Parameter	Length	8 byte																												
	Range	Within range of Pan and Tilt movable range																												
	Default Range (normal mounting)	Pan : -889~ +889 (7C87h~8379h)																												
		Tilt : -267~ +267 (7EF5h~810Bh)																												
	Default Range (inverse mounting)	Pan : -1511~ +1511 (7A19h~85E7h)																												
Tilt : -800~ +89 (7CE0h~8059h)																														
Status	None																													
Reference	<ul style="list-style-type: none"> <li>•Parameter value (1LSB) of both Pan/Tilt is equal to approx. 0.1125 by converting to angle. (see <b>12.17</b> and <b>12.18</b>)</li> <li>•Parameter section (8 byte) splits p0~p3 as Pan (position) section, and p4~p7 as Tilt (position) section.</li> <li>•The range of each parameter is effective within the range set by <b>Pan Movable Range Assignment (12.27)</b> and <b>Tilt Movable Range Assignment (12.28)</b>.</li> <li>•The right direction of Pan angle (position) is positive at the home position and the left one is passive. The upper direction of Tilt angle (position) is positive at the home position and the lower one is passive.</li> <li>•Assign each parameter with the angle (position) at home position. (home position is 8000h)</li> </ul> <p style="margin-left: 20px;">Assigned sample of Pan/tilt angle(position) as below</p> <table style="margin-left: 40px; border: none;"> <tr> <td>Pan right 90 degrees</td> <td>⇒</td> <td>+90/0.1125</td> <td>⇒</td> <td>+800</td> <td>⇒</td> <td>+320h</td> </tr> <tr> <td></td> <td></td> <td></td> <td></td> <td></td> <td>⇒</td> <td>8000h+320h = 8320h</td> </tr> <tr> <td>Tilt lower 30 degrees</td> <td>⇒</td> <td>-30/0.1125</td> <td>⇒</td> <td>-267</td> <td>⇒</td> <td>-10Bh</td> </tr> <tr> <td></td> <td></td> <td></td> <td></td> <td></td> <td>⇒</td> <td>8000h-10Bh = 7EF5h</td> </tr> </table> <ul style="list-style-type: none"> <li>•<b>Pan/Tilt Stop</b> command can stop motion by force. The running speed can be set by <b>Pan/Tilt Speed Assignment</b> command.</li> <li>•By issuing this command, Pan/tilt will be in action simultaneously and Pan and Tilt flag in action among the running status, set 1 and when Pan/Tilt motion stop, Pan/Tilt flags in action clear to zero.</li> </ul> <p>Note: After power ON, in case of receipt of this command without executing <b>Pedestal Initialize 1 &amp; 2</b>, return mode error and execute <b>Pedestal Initialize2</b>.</p>		Pan right 90 degrees	⇒	+90/0.1125	⇒	+800	⇒	+320h						⇒	8000h+320h = 8320h	Tilt lower 30 degrees	⇒	-30/0.1125	⇒	-267	⇒	-10Bh						⇒	8000h-10Bh = 7EF5h
Pan right 90 degrees	⇒	+90/0.1125	⇒	+800	⇒	+320h																								
					⇒	8000h+320h = 8320h																								
Tilt lower 30 degrees	⇒	-30/0.1125	⇒	-267	⇒	-10Bh																								
					⇒	8000h-10Bh = 7EF5h																								

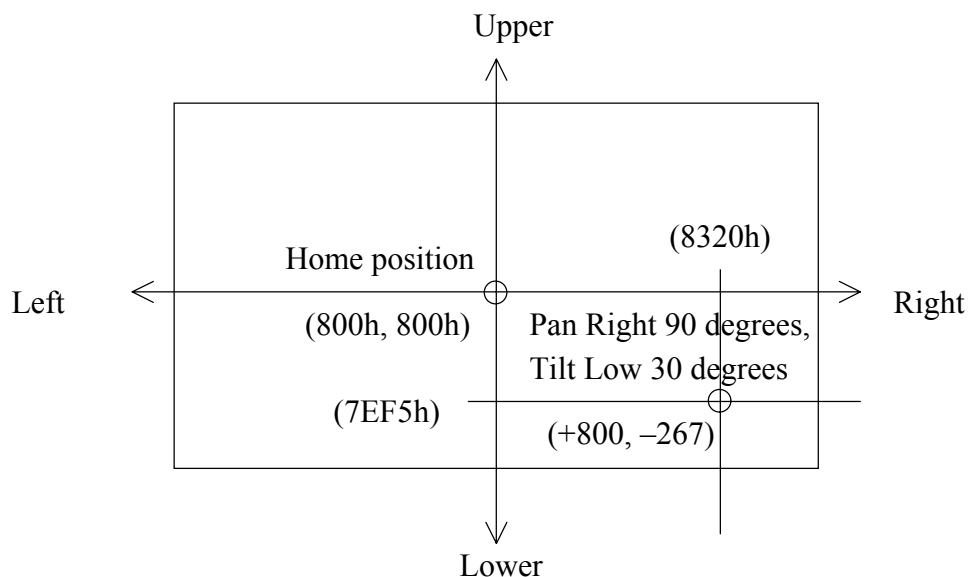

● Format of Control Code

d0	d1	d2	d3	d4										
Header	Device Num		Command											
FFh	30h	3Xh	00h	62h										
	d5	d6	d7	d8	d9	d10	d11	d12	d13					
	Pan Angle Parameter				Tilt Angle Parameter				End mark					
	p0	p1	p2	p3	p4	p5	p6	p7	EFh					



Running speed indicates hexadecimal 8 figures and returns ASCII as parameter value.								
Example:	Pan right 90 degrees			Tilt lower 30 degrees				
	Pan			p0	p1	p2	p3	
	+800	⇒	8320h	⇒	38h	33h	32h	30h
	Tilt			p4	p5	p6	p7	
	-267	⇒	7EF5h	⇒	37h	45h	46h	35h

● Answer Format

d0	d1	d2	d3	d4	d5
Header	Device Num		Error Code		End mark
FEh	30h	3Xh	e0	e1	EFh



Error Flag indicates in 2 figures hexadecimal and returns ASCII code value.		
Example:		e0 e1
■ In case of No Error :	00000000B	⇒ 00h ⇒ 30h 30h
■ In case of Busy :	00010000B	⇒ 10h ⇒ 31h 30h
■ In case of Parameter Error :	01010000B	⇒ 50h ⇒ 35h 30h
■ In case of Mode Error :	10010000B	⇒ 90h ⇒ 39h 30h

● Condition of Error flag to be set

Busy	<ul style="list-style-type: none"> <li>•In case of executing <b>Home Position</b>, <b>Pedestal Initialize 1</b> and <b>Pedestal Initialize 2</b> commands.</li> <li>•In case of executing <b>Pan/Tilt Angle Assignment</b> and <b>Preset Move</b> commands.</li> <li>•In case of Panning by <b>Pedestal Control</b> command.</li> <li>•In case of Tilting by <b>Pedestal Control</b> command.</li> </ul>
Parameter Error	<ul style="list-style-type: none"> <li>•Assign illegal parameters.</li> <li>•In case that Pan/Tilt angle(position) is out-of-range <b>Pan/Tilt Movable Range</b>.</li> </ul>
Mode Error	<ul style="list-style-type: none"> <li>•After power ON, not executed pedestal initialize.</li> <li>•Not in status of <b>Camera ON</b>.</li> <li>•Not in status of <b>Host Control Mode</b>.</li> </ul>

## 12.26 Pan/Tilt Angle Request

Pedestal Control Command Type 1

Function	To request angle (position) in Pan/Tilt direction.	
Command	0063h	
Parameter	None	
Status	Length	8 byte (Pan angle: 4 bytes, tilt angle: 4 bytes)
	Range	Within range of Pan and Tilt Movable Range
Reference	<ul style="list-style-type: none"> <li>•Parameter value (1LSB) of both Pan/Tilt is equal to approx. 0.1125 by converting to angle. (see <b>12.17</b> and <b>12.18</b>)</li> <li>•Status section (8 byte) splits s0~s3 as Pan (position) section, and s4~s7 as Tilt (position) section.</li> <li>•The value of each status is indicated as angle at <b>Home Position</b> (8000h) (See <b>12.25 Pan/Tilt Angle Assignment</b>.)</li> <li>•This command returns the angle (position), at the moment of receipt of Command even though Pan/Tilt is in action except executing <b>Pedestal Initialize 1 &amp; 2</b>.</li> </ul> <p>Note : After power ON, in case of receipt of this command without executing <b>Pedestal Initialize 1 &amp; 2</b>, return mode error.</p>	

### ● Format of Control Code

d0	d1	d2	d3	d4	d5
Header	Device Num		Command		End mark
FFh	30h	3Xh	00h	63h	EFh

### ● Answer Format

#### ■ In case of No Error

d0	d1	d2	d3	d4						
Header	Device Num		Error Code							
EFh	30h	3Xh	30h	30h						
	d5	d6	d7	d8	d9	d10	d11	d12	d13	
	Pan Angel Status				Tilt Angle Status				End mark	
	s0	s1	s2	s3	s4	s5	s6	s7	EFh	



The present position indicates in hexadecimal 8 figures and its ASCII is as parameter value.

Example:	Pan right 90 degrees				Tilt lower 30 degrees			
	Pan				s0	s1	s2	s3
	+800	⇒	8320h	⇒	38h	33h	32h	30h
	Tilt				s4	s5	s6	s7
	-267	⇒	7EF5h	⇒	37h	45h	46h	35h

■ In case of Error

d0	d1	d2	d3	d4	d5
Header	Device Num		Error Code		End mark
FEh	30h	3Xh	e0	e1	EFh



Error Flag indicates in 2 figures hexadecimal and returns ASCII code value.	
Example:	e0 e1
■ In case of Busy :	00010000B ⇒ 10h ⇒ 31h 30h
■ In case of Mode Error :	10010000B ⇒ 90h ⇒ 39h 30h

● Condition of Error flag to be set

Busy	<ul style="list-style-type: none"> <li>•In case of executing <b>Pedestal Initialize 1</b> and <b>Pedestal Initialize 2</b> commands.</li> </ul>
Mode Error	<ul style="list-style-type: none"> <li>•After Power ON, not executed pedestal initialize.</li> <li>•Not in status of <b>Camera ON</b>.</li> <li>•Not in status of <b>Host Control Mode</b>.</li> </ul>

## 12.27 Pan Movable Range Assignment

Pedestal Control Command Type 1

Function	To assign movable range in Pan direction.	
Command	0064h	
Parameter	Length	9 byte
	Range	Normal Mounting: -889~+889 (7C87h~8379h) Inverse Mounting: -1511~+1511 (7A19h~85E7h)
Status	None	
Reference	<ul style="list-style-type: none"> <li>•Maximum &amp; minimum (position) movable angle can be set, when Pan motion command is set by <b>Pan Right Start</b> and <b>Pan Left Start</b> are executed.</li> <li>•To set Pan maximum &amp; minimum angle (position) which can be set by <b>Pan/Tilt Angle Assignment</b> command.</li> <li>•Parameter value (1LSB) of Pan is equal to approx. 0.1125 by converting to angle. (see 12.17)</li> <li>•Minimum parameter value can be obtained by <b>Pan Minimum Angle Request</b> command (12.19) and maximum value can be obtained by <b>Pan Maximum Angle Request</b> (12.20).</li> <li>•Parameter section (9byte) splits minimum angle (position) as p1~p4 and maximum angle (position) as p5~p8.</li> <li>•Minimum &amp; maximum Pan parameter value is to set at angle of <b>Home Position</b> (8000h). See 12.25 <b>Pan/Tilt Angle Assignment</b></li> <li>•Not necessary to include <b>Home Position</b> between minimum and maximum angle (position). But minimum angle value must set equal or less value of maximum value.</li> <li>•When <b>Pedestal Initialize 1</b> command executes, move to <b>Home Position</b>, even though out of range.</li> <li>•In case that Pan position is out of range before executing <b>Pedestal Initialize 2</b> command, it return to minimum or maximum position within motion range by the return motion.</li> </ul>	

### ● Format of Control Code

d0	d1	d2	d3	d4										
Header	Device Num		Command											
FFh	30h	3Xh	00h	64h										
d5	d6	d7	d8	d9	d10	d11	d12	d13	d14					
Fixed	Minimum Angle Parameter				Maximum Angle Parameter				End mark					
30h	p1	p2	p3	p4	p5	p6	p7	p8	EFh					



Running speed indicates in hexadecimal 8 figures and returns ASCII as parameter value.							
Example: Min Value (left) 90 degrees, Max Value (right) 45 degrees							
				p1	p2	p3	p4
Left	-800	⇒	7CE0h	⇒	37h	43h	45h
				p5	p6	p7	p8
Right	+400	⇒	8190h	⇒	38h	31h	39h

Example: Minimum (Left) 90 degrees, Maximum (Right) 45 degrees

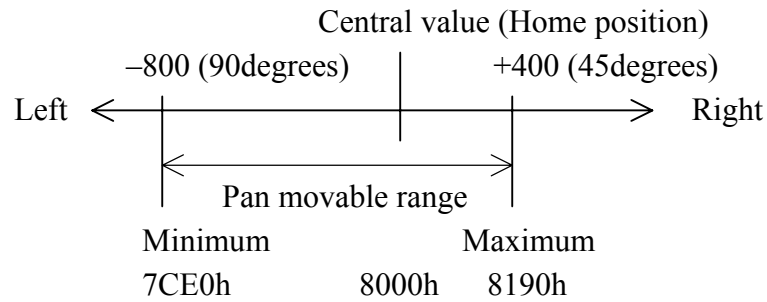

● Answer Format

d0	d1	d2	d3	d4	d5
Header	Device Num		Error Code		End mark
FEh	30h	3Xh	e0	e1	EFh



Error Flag indicates in 2 figures hexadecimal and returns ASCII code value		
Example:		e0 e1
■ In case of No Error :	00000000B ⇒ 00h ⇒	30h 30h
■ In case of Busy :	00010000B ⇒ 10h ⇒	31h 30h
■ In case of Parameter Error :	01010000B ⇒ 50h ⇒	35h 30h
■ In case of Mode Error :	10010000B ⇒ 90h ⇒	39h 30h

● Condition of Error flag to be set

Busy	<ul style="list-style-type: none"> <li>•In case of executing <b>Home Position, Pedestal Initialize 1</b> and <b>Pedestal Initialize 2</b> commands.</li> <li>•In case of executing <b>Preset Move</b> commands.</li> <li>•Executing Pan/Tilt running by <b>Pedestal Control</b> command.</li> </ul>
Parameter Error	<ul style="list-style-type: none"> <li>•In case of assigned parameter over value to the Max. &amp; Min parameter range.</li> <li>•In case of assigned minimum value over maximum value.</li> </ul>
Mode Error	<ul style="list-style-type: none"> <li>•Not in status of <b>Camera ON</b>.</li> <li>•Not in status of <b>Host Control Mode</b>.</li> </ul>



**12.28 Tilt Movable Range Assignment**

Function	To assign movable range in Tilt direction.	
Command	0064h	
Parameter	Length	9 byte
	Range	Normal Mounting: -267~+800 (7EF5h~8320h) Inverse Mounting: -800~+89 (7CE0h~8059h)
Status	None	
Reference	<ul style="list-style-type: none"> <li>•Maximum &amp; minimum (position) movable angle can be set, when Tilt motion command is set by <b>Tilt Up and Down Start</b> Tilt motion setting command and etc. and set Tilt maximum &amp; minimum angle (position) which can be set by <b>Pan/Tilt Angle Assignment</b> command.</li> <li>•Parameter value (1LSB) of Pan is equal to approx. 0.1125 by converting to angle (see 12.18).</li> <li>•Minimum parameter value can be obtained by <b>Tilt Minimum Angle Request</b> command (12.21) and maximum value can be obtained by <b>Tilt Maximum Angle Request</b> (12.22).</li> <li>•Parameter section (9byte) splits fixed value as p0, minimum angle (position) as p1~p4 and maximum angle (position) as p5~p8.</li> <li>•Minimum &amp; maximum Tilt parameter value is to set at angle of <b>Home Position</b> (8000h). See 12.25 <b>Pan/Tilt Angle Assignment</b>.</li> <li>•Not necessary to include <b>Home Position</b> between minimum and maximum angle (position). But minimum angle value must set equal or less value of maximum value.</li> <li>•When <b>Pedestal Initialize 1</b> command executes, moves to <b>Home Position</b>, even though out of range.</li> <li>•In case that Tilt position is out of range before executing <b>Pedestal Initialize 2</b> command, it returns to minimum or maximum position within motion range by the return motion.</li> </ul>	

● Format of Control Code

d0	d1	d2	d3	d4										
Header	Device Num		Command											
FFh	30h	3Xh	00h	64h										
d5	d6	d7	d8	d9	d10	d11	d12	d13	d14					
Fixed	Minimum Angle Parameter				Maximum Angle parameter				End mark					
31h	p1	p2	p3	p4	p5	p6	p7	p8	EFh					

↓

Running speed indicates in hexadecimal 8 figures and returns ASCII as parameter value.							
Example: Min Value (lower) 30 degrees, Max Value (upper) 10 degrees							
			p1	p2	p3	p4	
Lower	-267	⇒	7EF5h	⇒	37h	45h	46h 35h
			p5	p6	p7	p8	
Upper	+89	⇒	8059h	⇒	38h	30h	35h 39h

Example: Minimum (Lower) 30 degrees, Maximum (Upper) 10 degrees

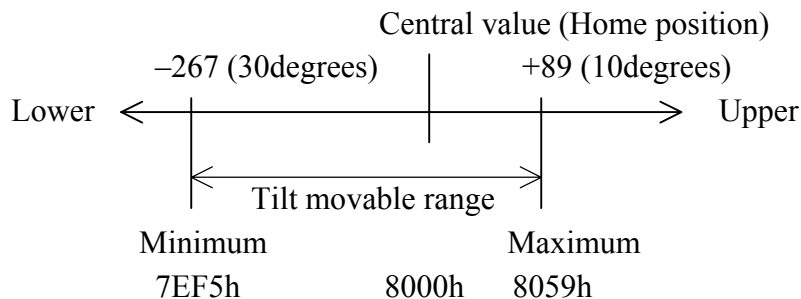

● Answer Format

d0	d1	d2	d3	d4	d5
Header	Device Num		Error Code		End mark
FEh	30h	3Xh	e0	e1	EFh



Error Flag indicates in 2 figures hexadecimal and returns ASCII code value.					
Example:					
				e0	e1
■ In case of No Error :	00000000B	⇒	00h	⇒	30h 30h
■ In case of Busy :	00010000B	⇒	10h	⇒	31h 30h
■ In case of Parameter Error :	01010000B	⇒	50h	⇒	35h 30h
■ In case of Mode Error :	10010000B	⇒	90h	⇒	39h 30h

● Condition of Error flag to be set

Busy	<ul style="list-style-type: none"> <li>•In case of executing <b>Home Position, Pedestal Initialize 1</b> and <b>Pedestal Initialize 2</b> commands.</li> <li>•In case of executing <b>Preset Move</b> commands.</li> <li>•Executing Pan/Tilt running by <b>Pedestal Control</b> command.</li> </ul>
Parameter Error	<ul style="list-style-type: none"> <li>•In case of assigned parameter over value to the Max &amp; Min parameter range.</li> <li>•In case of assigned minimum value over maximum value.</li> </ul>
Mode Error	<ul style="list-style-type: none"> <li>•Not in status of <b>Camera ON</b>.</li> <li>•Not in status of <b>Host Control Mode</b>.</li> </ul>

## 12.29 Pan Movable Range Request

Pedestal Control Command Type 1

Function	To request movable range in Pan direction.	
Command	0065h	
Parameter	Length	1 byte
	Value	0h
Status	Length	8 byte
	Range	Normal Mounting: -889 ~ +889 (7C87h~8379h)
		Inverse Mounting: -1511 ~ +1511 (7A19h~85E7h)
Reference	<ul style="list-style-type: none"> <li>Parameter value (1LSB) of Pan is equal to approx. 0.1125 by converting to angle (see <b>12.17</b>).</li> <li>Parameter section (8byte) splits minimum angle (position) as s0~s3 and maximum angle (position) as s4~s7.</li> <li>Minimum &amp; maximum parameter value is to set at angle of <b>Home Position</b> (8000h). See <b>12.27 Pan Movable Range Assignment</b>.</li> </ul>	

### ● Format of Control Code

d0	d1	d2	d3	d4	d5	d6
Header	Device Num		Command		Parameter	End mark
FFh	30h	3Xh	00h	65h	30h	EFh

### ● Answer Format

#### ■ In case of No Error

d0	d1	d2	d3	d4	d5	d6	d7	d8	d9	d10	d11	d12	d13
Header	Device Num		Error Code		Minimum Angle Status				Maximum Angle Status				End mark
FEh	30h	3Xh	30h	30h	s0	s1	s2	s3	s4	s5	s6	s7	EFh



Running speed indicates in hexadecimal 8 figures and returns ASCII as parameter value.							
Example: Min Value (lower) 90 degrees, Max Value (upper) 45 degrees							
				s0	s1	s2	s3
Right	-889	⇒	7C87h	⇒	37h	43h	38h 37h
				s4	s5	s6	s7
Left	+267	⇒	810Bh	⇒	38h	31h	30h 42h

#### ■ In case of Error

d0	d1	d2	d3	d4	d5
Header	Device Num		Error Code		End mark
FEh	30h	3Xh	e0	e1	EFh



Error Flag indicates in 2 figures hexadecimal and returns ASCII code value.		
Example:		
		e0 e1
■ In case of Parameter Error :	01010000B ⇒ 50h ⇒	35h 30h
■ In case of Mode Error :	10010000B ⇒ 90h ⇒	39h 30h

### ● Condition of Error flag to be set

Parameter Error	•Assign illegal parameters.
Mode Error	•Not in status of <b>Camera ON</b> . •Not in status of <b>Host Control Mode</b> .

### 12.30 Tilt Movable Range Request

Pedestal Control Command Type 1

Function	To request movable range in Tilt direction.	
Command	0065h	
Parameter	Length	1 byte
	Value	1h
Status	Length	8 byte
	Range	Normal Mounting: -267 ~ +800 (7EF5h~8320h)
		Inverse Mounting: -800 ~ +89 (7CE0h~8059h)
Reference	<ul style="list-style-type: none"> <li>•Parameter value (1LSB) of Tilt is equal to approx. 0.1125 by converting to angle (see <b>12.18</b>).</li> <li>•Parameter section (8byte) splits minimum angle (position) as s0~s3 and maximum angle (position) as s4~s7.</li> <li>•Minimum &amp; maximum parameter value is to set at angle of <b>Home Position</b> (8000h). See <b>12.28 Tilt Movable Range Assignment</b>.</li> </ul>	

● Format of Control Code

d0	d1	d2	d3	d4	d5	d6
Header	Device Num		Command		Parameter	End mark
FFh	30h	3Xh	00h	65h	31h	EFh

● Answer Format

■ In case of No Error

d0	d1	d2	d3	d4	d5	d6	d7	d8	d9	d10	d11	d12	d13
Header	Device Num		Error Code		Minimum Angle Status				Maximum Angle Status				End mark
FEh	30h	3Xh	30h	30h	s0	s1	s2	s3	s4	s5	s6	s7	EFh



Running speed indicates in hexadecimal 8 figures and returns ASCII as parameter value.							
Example: Min Value (lower) 30 degrees, Max Value (upper) 10 degrees							
				s0	s1	s2	s3
Lower	-267	⇒	7EF5h	⇒	37h	45h	46h 35h
				s4	s5	s6	s7
Upper	+89	⇒	8059h	⇒	38h	30h	35h 39h

■ In case of Error

d0	d1	d2	d3	d4	d5
Header	Device Num		Error Code		End mark
FEh	30h	3Xh	e0	e1	EFh



Error Flag indicates in 2 figures hexadecimal and returns ASCII code value.			
Example:			
■ In case of Parameter Error :	01010000B	⇒	50h ⇒ 35h 30h
■ In case of Mode Error :	10010000B	⇒	90h ⇒ 39h 30h

● Condition of Error flag to be set

Parameter Error	•Assign illegal parameters.
Mode Error	•Not in status of <b>Camera ON</b> . •Not in status of <b>Host Control Mode</b> .

### 13. Details of Camera Control Commands

#### 13.1 Camera OFF

Camera Control Command Type 2

Function	To stop operation of camera and pedestal, and camera section power OFF.	
Command	00A0h	
Parameter	Length	1 byte
	Value	0h
Status	None	
Reference	<ul style="list-style-type: none"> <li>•To power camera section OFF (Picture signal of camera comes out OFF).</li> <li>•If this command issues, this command is waiting status until initialize operation finish, when <b>Pedestal Initialize 1 &amp; 2</b> are in process. (Pan/Tilt motion operation besides the above, will be forced to stop.)</li> <li>•During this process of camera OFF by this command, Busy error will occur, when <b>Camera ON</b> or <b>Camera OFF</b> command is issued.</li> <li>•By issuing this command, flag of <b>Camera Power OFF</b> command is set as 1.</li> <li>•After this setting, the command except the following command will come out mode error. <ul style="list-style-type: none"> <li>•<b>Operation Status Request, Extended Operation Status Request</b> command.</li> <li>•<b>Camera ON, Camera OFF</b> command.</li> <li>•<b>LED Normal Display, LED Forced Control</b> command.</li> <li>•<b>Cascade ON, Cascade OFF</b> command.</li> <li>•<b>Host Control Mode, Local Control Mode</b> command.</li> <li>•<b>Global Notification Setting</b> command.</li> </ul> </li> </ul>	

#### ● Format of Control Code

d0	d1	d2	d3	d4	d5	d6
Header	Device Num		Command		Parameter	End mark
FFh	30h	3Xh	00h	A0h	30h	EFh

#### ● Answer Format

d0	d1	d2	d3	d4	d5
Header	Device Num		Error Code		End mark
FEh	30h	3Xh	e0	e1	EFh



Error Flag indicates in 2 figures hexadecimal and returns ASCII code value.	
Example:	e0 e1
■ In case of No Error :	0000000B ⇒ 00h ⇒ 30h 30h
■ In case of Busy :	0001000B ⇒ 10h ⇒ 31h 30h
■ In case of Parameter Error :	0101000B ⇒ 50h ⇒ 35h 30h
■ In case of Mode Error :	1001000B ⇒ 90h ⇒ 39h 30h

#### ● Condition of Error flag to be set

Busy	<ul style="list-style-type: none"> <li>•In case of executing <b>Camera ON</b> command.</li> <li>•In case of executing <b>Camera OFF</b> command.</li> </ul>
Parameter Error	•Assign illegal parameters.
Mode Error	•Not in status of <b>Host Control Mode</b> .

### 13.2 Camera ON

### Camera Control Command Type 2

Function	To camera section power ON, and start operation of camera and pedestal.	
Command	00A0h	
Parameter	Length	1 byte
	Value	1h
Status	None	
Reference	<ul style="list-style-type: none"> <li>•To power camera section power ON (Picture signal of camera turns out).</li> <li>•Zoom position, AE target value (Back light compensation status, BRIGHT), Shutter speed 1/100 (flicker less AE) will return to the setting condition prior to executing <b>Camera OFF</b> command and another set values come out default value.</li> <li>•During this process of camera ON by this command, Busy error will occur, when <b>Camera ON</b> or <b>Camera OFF</b> command is issued.</li> <li>•After camera ON process finished, flag of <b>Camera Power OFF</b> among operating status comes out zero.</li> <li>•In order to confirm power ON by this command, necessary to confirm <b>Power OFF</b> flag of camera section in operated status or answer of termination notification at <b>Camera ON</b> command after finishing command termination notification.</li> </ul>	

#### ● Format of Control Code

d0	d1	d2	d3	d4	d5	d6
Header	Device Num		Command		Parameter	End mark
FFh	30h	3Xh	00h	A0h	31h	EFh

#### ● Answer Format

d0	d1	d2	d3	d4	d5
Header	Device Num		Error Code		End mark
FEh	30h	3Xh	e0	e1	EFh



Error Flag indicates in 2 figures hexadecimal and returns ASCII code value.	
Example:	e0 e1
■ In case of No Error :	0000000B ⇒ 00h ⇒ 30h 30h
■ In case of Busy :	00010000B ⇒ 10h ⇒ 31h 30h
■ In case of Parameter Error :	01010000B ⇒ 50h ⇒ 35h 30h
■ In case of Mode Error :	10010000B ⇒ 90h ⇒ 39h 30h

#### ● Condition of Error flag to be set

Busy	<ul style="list-style-type: none"> <li>•In case of executing <b>Camera ON</b> command.</li> <li>•In case of executing <b>Camera OFF</b> command.</li> </ul>
Parameter Error	•Assign illegal parameters.
Mode Error	•Not in status of <b>Host Control Mode</b> .

### 13.3 Focus Automatic

Function	To set auto focus mode.	
Command	00A1h	
Parameter	Length	1 byte
	Value	0h
Status	None	
Reference	<ul style="list-style-type: none"> <li>•Flags in <b>Focusing of Operation Status Request</b> and <b>Manual Focus</b> come out 0 at AF mode.</li> <li>•AF mode sets default value at the time of executing <b>Camera Reset</b>, <b>Camera ON</b> command during power ON.</li> </ul>	

● Format of Control Code

d0	d1	d2	d3	d4	d5	d6
Header	Device Num		Command		Parameter	End mark
FFh	30h	3Xh	00h	A1h	30h	EFh

● Answer Format

d0	d1	d2	d3	d4	d5
Header	Device Num		Error Code		End mark
FEh	30h	3Xh	e0	e1	EFh



Error Flag indicates in 2 figures hexadecimal and returns ASCII code value.	
Example:	e0 e1
■ In case of No Error :	00000000B ⇒ 00h ⇒ 30h 30h
■ In case of Busy :	00010000B ⇒ 10h ⇒ 31h 30h
■ In case of Mode Error :	10010000B ⇒ 90h ⇒ 39h 30h

● Condition of Error flag to be set

Busy	<ul style="list-style-type: none"> <li>•In process of camera initializing operation by <b>Camera Reset</b> command, etc.</li> <li>•In process of focus operation by manual.</li> <li>•In process of <b>One Push AF</b> operation.</li> <li>•In case of executing <b>Preset Move</b> command.</li> </ul>
Mode Error	<ul style="list-style-type: none"> <li>•Not in status of <b>Camera ON</b>.</li> <li>•Not in status of <b>Host Control Mode</b>.</li> </ul>

### 13.4 Focus Manual

### Camera Control Command Type 1

Function	To stop focus operation and set manual mode.	
Command	00A1h	
Parameter	Length	1 byte
	Value	1h
Status	None	
Reference	<ul style="list-style-type: none"> <li>•In case of auto focus mode, cancels AF mode and set manual mode.</li> <li>•To stop focus operation under focusing by manual mode.</li> <li>•<b>Flags in Focusing of Operation Status Request</b> comes out zero and <b>Manual Focus</b> comes out 1.</li> </ul>	

#### ● Format of Control Code

d0	d1	d2	d3	d4	d5	d6
Header	Device Num		Command		Parameter	End mark
FFh	30h	3Xh	00h	A1h	31h	EFh

#### ● Answer Format

d0	d1	d2	d3	d4	d5
Header	Device Num		Error Code		End mark
FEh	30h	3Xh	e0	e1	EFh



Error Flag indicates in 2 figures hexadecimal and returns ASCII code value.	
Example:	e0 e1
■ In case of No Error :	00000000B ⇒ 00h ⇒ 30h 30h
■ In case of Busy :	00010000B ⇒ 10h ⇒ 31h 30h
■ In case of Mode Error :	10010000B ⇒ 90h ⇒ 39h 30h

#### ● Condition of Error flag to be set

Busy	<ul style="list-style-type: none"> <li>•In process of camera initializing operation by <b>Camera Reset</b> command, etc.</li> <li>•In process of <b>One Push AF</b> operation.</li> <li>•In case of executing <b>Preset Move</b> command.</li> </ul>
Mode Error	<ul style="list-style-type: none"> <li>•Not in status of <b>Camera ON</b>.</li> <li>•Not in status of <b>Host Control Mode</b>.</li> </ul>



### 13.5 Focus Near

Function	To move focus point near.	
Command	00A1h	
Parameter	Length	1 byte
	Value	2h
Status	None	
Reference	<ul style="list-style-type: none"> <li>•In case of auto focus mode, cancels AF mode and set manual mode.</li> <li>•<b>Flags in Focusing of Operation Status Request</b> comes out zero and <b>Manual Focus</b> comes out 1.</li> <li>•By <b>Focus Manual</b> command, possible to stop running.</li> <li>•To stop running at focus limit point (Near point) and flag in focusing comes out zero.</li> <li>•To return notification at the moment of reaching to focus operation limit (Near point), when command termination notification ON is to be set.</li> </ul> <p>Note: In case that focus is already in focus operation limit (Near point), <b>flag in focusing</b> doesn't set 1 because of focus not operating.</p>	

● Format of Control Code

d0	d1	d2	d3	d4	d5	d6
Header	Device Num		Command		Parameter	End mark
FFh	30h	3Xh	00h	A1h	32h	EFh

● Answer Format

d0	d1	d2	d3	d4	d5
Header	Device Num		Error Code		End mark
FEh	30h	3Xh	e0	e1	EFh



Error Flag indicates in 2 figures hexadecimal and returns ASCII code value.	
Example:	e0 e1
■ In case of No Error :	00000000B ⇒ 00h ⇒ 30h 30h
■ In case of Busy :	00010000B ⇒ 10h ⇒ 31h 30h
■ In case of Mode Error :	10010000B ⇒ 90h ⇒ 39h 30h

● Condition of Error flag to be set

Busy	<ul style="list-style-type: none"> <li>•In process of camera initializing operation by <b>Camera Reset</b> command, etc.</li> <li>•In process of focus operation by manual.</li> <li>•In process of <b>One Push AF</b> operation.</li> <li>•In process of zooming operation.</li> <li>•In case of executing <b>Preset Move</b> command.</li> </ul>
Mode Error	<ul style="list-style-type: none"> <li>•Not in status of <b>Camera ON</b>.</li> <li>•Not in status of <b>Host Control Mode</b>.</li> </ul>

### 13.6 Focus Far

Function	To move focus point far.	
Command	00A1h	
Parameter	Length	1 byte
	Range	3h
Status	None	
Reference	<ul style="list-style-type: none"> <li>•In case of Auto Focus mode, cancel AF mode and set manual mode.</li> <li>•<b>Flags in Focusing of Operation Status Request</b> comes out zero and <b>Manual Focus</b> comes out 1.</li> <li>•By <b>Focus Manual</b> command, possible to stop running.</li> <li>•To stop running at Focus Limit point (Far point) and <b>flag in focusing</b> comes out zero.</li> <li>•To return notification at the moment of reaching to focus operation limit (Far point), when command termination notification ON is to be set.</li> </ul> <p>Note: In case that focus is already in focus operation limit (Far point), <b>flag in focusing</b> doesn't set 1 because of focus not operating.</p>	

● Format of Control Code

d0	d1	d2	d3	d4	d5	d6
Header	Device Num		Command		Parameter	End mark
FFh	30h	3Xh	00h	A1h	33h	EFh

● Answer Format

d0	d1	d2	d3	d4	d5
Header	Device Num		Error Code		End mark
FEh	30h	3Xh	e0	e1	EFh



Error Flag indicates in 2 figures hexadecimal and returns ASCII code value.	
Example:	e0 e1
■ In case of No Error :	00000000B ⇒ 00h ⇒ 30h 30h
■ In case of Busy :	00010000B ⇒ 10h ⇒ 31h 30h
■ In case of Mode Error :	10010000B ⇒ 90h ⇒ 39h 30h

● Condition of Error flag to be set

Busy	<ul style="list-style-type: none"> <li>•In process of camera initializing operation by <b>Camera Reset</b> command, etc.</li> <li>•In process of focus operation by manual.</li> <li>•In process of <b>One Push AF</b> operation.</li> <li>•In process of zooming operation.</li> <li>•In case of executing <b>Preset Move</b> command.</li> </ul>
Mode Error	<ul style="list-style-type: none"> <li>•Not in status of <b>Camera ON</b>.</li> <li>•Not in status of <b>Host Control Mode</b>.</li> </ul>

### 13.7 Focus Position Assignment

Function	To move focus position assigned.	
Command	00B0h	
Parameter	Length	4 byte
	Range	Within the range to be returned by <b>Focus Range Request</b>
Status	None	
Reference	<ul style="list-style-type: none"> <li>•In case of Auto Focus mode, cancel AF mode and set manual mode.</li> <li>•<b>Flags in Focusing of Operation Status Request</b> and <b>Manual Focus</b> come out 1 and when focus stops after moving assigned point, <b>flag in focusing</b> comes out zero.</li> <li>•By <b>Focus Manual</b> command, stop focusing, and <b>flag in focusing</b> comes out zero.</li> <li>•Return notification at the moment of reaching to assigned point, when command termination notification ON is to be set. But not return notification, in case of stopping <b>Focus by Manual</b> command before reaching assigned point.</li> </ul>	

● Format of Control Code

	d0	d1	d2	d3	d4	d5	d6	d7	d8	d9
Header	Device Num		Command		Parameter				End mark	
FFh	30h	3Xh	00h	B0h	p0	p1	p2	p3	EFh	



Focus position indicates in 4 figures hexadecimal and its ASCII code is Parameter value.
Example: 256 ⇒ 0100h ⇒ p0 p1 p2 p3 30h 31h 30h 30h

● Answer Format

	d0	d1	d2	d3	d4	d5
Header	Device Num		Error Code		End mark	
FEh	30h	3Xh	e0	e1	EFh	



Error Flag indicates in 2 figures hexadecimal and returns ASCII code value.
Example: <ul style="list-style-type: none"> <li>■ In case of No Error : 0000000B ⇒ 00h ⇒ 30h 30h</li> <li>■ In case of Busy : 0001000B ⇒ 10h ⇒ 31h 30h</li> <li>■ In case of Parameter Error : 0101000B ⇒ 50h ⇒ 35h 30h</li> <li>■ In case of Mode Error : 1001000B ⇒ 90h ⇒ 39h 30h</li> </ul>

● Condition of Error flag to be set

Busy	<ul style="list-style-type: none"> <li>•In process of camera initializing operation by <b>Camera Reset</b> command, etc.</li> <li>•In process of focus operation by manual.</li> <li>•In process of <b>One Push AF</b> operation.</li> <li>•In process of zooming operation.</li> <li>•In case of executing <b>Preset Move</b> command.</li> </ul>
Parameter Error	•In case of assigned parameter over value to upper and lower.
Mode Error	<ul style="list-style-type: none"> <li>•Not in status of <b>Camera ON</b>.</li> <li>•Not in status of <b>Host Control Mode</b>.</li> </ul>

### 13.8 Focus Position Request

Camera Control Command Type 1

Function	To return present focus position.	
Command	00B1h	
Parameter	Length	1 byte
	Value	0h
Status	Length	4 byte
	Range	Within range to be return by <b>Focus Range Request</b>
Reference		

● Format of Control Code

d0	d1	d2	d3	d4	d5	d6
Header	Device Num		Command		Parameter	End mark
FFh	30h	3Xh	00h	B1h	30h	EFh

● Answer Format

■ In case of No Error

d0	d1	d2	d3	d4	d5	d6	d7	d8	d9
Header	Device Num		Error Code		Focus Position				End mark
FEh	30h	3Xh	30h	30h	s0	s1	s2	s3	EFh



Present position indicates in hexadecimal 4 figures and its ASCII code is Status value.							
Example:							
256	⇒	0100h	⇒	s0	s1	s2	s3
				30h	31h	30h	30h

■ In case of Error

d0	d1	d2	d3	d4	d5
Header	Device Num		Error Code		End mark
FEh	30h	3Xh	e0	e1	EFh



Error Flag indicates in 2 figures hexadecimal and returns ASCII code value.					
Example:					
				e0	e1
■ In case of Busy :	00010000B	⇒	10h	⇒	31h 30h
■ In case of Mode Error :	10010000B	⇒	90h	⇒	39h 30h

● Condition of Error flag to be set

Busy	<ul style="list-style-type: none"> <li>•In process of camera initializing operation by <b>Camera Reset</b> command, etc.</li> <li>•In case of executing <b>Preset Move</b> command.</li> </ul>
Mode Error	<ul style="list-style-type: none"> <li>•Not in status of <b>Camera ON</b>.</li> <li>•Not in status of <b>Host Control Mode</b>.</li> </ul>

### 13.9 One Push AF

### Camera Control Command Type 2

Function	To set manual mode after changing Mode to AF and getting focus.	
Command	00B1h	
Parameter	Length	1 byte
	Value	1h
Status	None	
Reference	<ul style="list-style-type: none"> <li>•<b>Flags in Focusing of Operation Status Request</b> in AF mode comes out zero and <b>Manual Focus</b> come out 1 after getting in focus.</li> <li>•To return notification at the moment of setting command termination notification ON</li> </ul>	

#### ● Format of Control Code

	d0	d1	d2	d3	d4	d5	d6
Header	Device Num		Command		Parameter	End mark	
FFh	30h	3Xh	00h	B1h	31h	EFh	

#### ● Answer Format

	d0	d1	d2	d3	d4	d5
Header	Device Num		Error Code		End mark	
FEh	30h	3Xh	e0	e1	EFh	



Error Flag indicates in 2 figures hexadecimal and returns ASCII code value.	
Example:	e0 e1
■ In case of No Error :	00000000B ⇒ 00h ⇒ 30h 30h
■ In case of Busy :	00010000B ⇒ 10h ⇒ 31h 30h
■ In case of Mode Error :	10010000B ⇒ 90h ⇒ 39h 30h

#### ● Condition of Error flag to be set

Busy	<ul style="list-style-type: none"> <li>•In process of camera initializing operation by <b>Camera Reset</b> command, etc.</li> <li>•In process of focus operation by manual.</li> <li>•In process of <b>One Push AF</b> operation.</li> <li>•In case of executing <b>Preset Move</b> command.</li> </ul>
Mode Error	<ul style="list-style-type: none"> <li>•Not in status of <b>Camera ON</b>.</li> <li>•Not in status of <b>Host Control Mode</b>.</li> </ul>

### 13.10 Focus Range Request

Camera Control Command Type 1

Function	To return movable range of focus.	
Command	00B1h	
Parameter	Length	1 byte
	Value	2h
Status	Length	8 byte
	Range	Change according to zoom position.
Reference		

● Format of Control Code

	d0	d1	d2	d3	d4	d5	d6
Header	Device Num		Command		Parameter	End mark	
FFh	30h	3Xh	00h	B1h	32h	EFh	

● Answer Format

■ In case of No Error

	d0	d1	d2	d3	d4								
Header	Device Num		Error Code										
FEh	30h	3Xh	30h	30h									
	d5	d6	d7	d8	d9	d10	d11	d12	d13				
	Minimum Movable value				Maximum Movable value				End mark				
	s0	s1	s2	s3	s4	s5	s6	s7	EFh				



Movable Range indicates in hexadecimal 8 figures and its ASCII is status value.					
Example:					
Movable Min. Value		s0	s1	s2	s3
256 ⇒	0100h ⇒	30h	31h	30h	30h
Movable Max. Value		s4	s5	s6	s7
512 ⇒	0200h ⇒	30h	32h	30h	30h

■ In case of Error

	d0	d1	d2	d3	d4	d5
Header	Device Num		Error Code		End mark	
FEh	30h	3Xh	e0	e1	EFh	



Error Flag indicates in 2 figures hexadecimal and returns ASCII code value.					
Example:					
			e0	e1	
■ In case of Busy :	00010000B ⇒	10h ⇒	31h	30h	
■ In case of Mode Error :	10010000B ⇒	90h ⇒	39h	30h	

● Condition of Error flag to be set

Busy	<ul style="list-style-type: none"> <li>•In process of camera initializing operation by <b>Camera Reset</b> command, etc.</li> <li>•In case of executing <b>Preset Move</b> command.</li> </ul>
Mode Error	<ul style="list-style-type: none"> <li>•Not in status of <b>Camera ON</b>.</li> <li>•Not in status of <b>Host Control Mode</b>.</li> </ul>

### 13.11 Zoom Stop

Camera Control Command Type 1

Function	To stop zoom operation.	
Command	00A2h	
Parameter	Length	1 byte
	Value	0h
Status	None	
Reference	<ul style="list-style-type: none"> <li>•<b>Flags in Zooming of Operation Status Request</b> comes out zero.</li> <li>•To set <b>Zoom Stop</b> by default at the moment of setting <b>Camera Reset</b>, <b>Camera ON</b> command during power ON.</li> </ul>	

● Format of Control Code

d0	d1	d2	d3	d4	d5	d6
Header	Device Num		Command		Parameter	End mark
FFh	30h	3Xh	00h	A2h	30h	EFh

● Answer Format

d0	d1	d2	d3	d4	d5
Header	Device Num		Error Code		End mark
FEh	30h	3Xh	e0	e1	EFh



Error Flag indicates in 2 figures hexadecimal and returns ASCII code value.		
Example:		e0 e1
■ In case of No Error :	00000000B ⇒ 00h ⇒	30h 30h
■ In case of Busy :	00010000B ⇒ 10h ⇒	31h 30h
■ In case of Mode Error :	10010000B ⇒ 90h ⇒	39h 30h

● Condition of Error flag to be set

Busy	<ul style="list-style-type: none"> <li>•In process of camera initializing operation by <b>Camera Reset</b> command, etc.</li> <li>•In case of executing <b>Preset Move</b> command.</li> </ul>
Mode Error	<ul style="list-style-type: none"> <li>•Not in status of <b>Camera ON</b>.</li> <li>•Not in status of <b>Host Control Mode</b>.</li> </ul>

### 13.12 Zoom Wide

### Camera Control Command Type 2

Function	Move the zoom to WIDE side at the selected zoom speed (0-7).	
Command	00A2h	
Parameter	Length	1 byte
	Value	1h
Status	None	
Reference	<ul style="list-style-type: none"> <li>• <b>Flags in Zooming of Operation Status Request</b> comes out 1.</li> <li>• Possible to stop running by <b>Zoom Stop</b> command.</li> <li>• To stop running at the zoom operation limit point (Wide), and <b>Flag in Zooming</b> comes out zero.</li> <li>• To return notification at the moment of reaching to zoom operation limit point (Wide).</li> </ul> <p>Note: When zoom position reached to the zoom operation limit position of wide end, <b>Flag in Zooming</b> doesn't come out 1 because of not zoom running.</p>	

#### ● Format of Control Code

d0	d1	d2	d3	d4	d5	d6
Header	Device Num		Command		Parameter	End mark
FFh	30h	3Xh	00h	A2h	31h	EFh

#### ● Answer Format

d0	d1	d2	d3	d4	d5
Header	Device Num		Error Code		End mark
FEh	30h	3Xh	e0	e1	EFh



Error Flag indicates in 2 figures hexadecimal and returns ASCII code value.	
Example:	e0 e1
■ In case of No Error :	0000000B ⇒ 00h ⇒ 30h 30h
■ In case of Busy :	0001000B ⇒ 10h ⇒ 31h 30h
■ In case of Mode Error :	1001000B ⇒ 90h ⇒ 39h 30h

#### ● Condition of Error flag to be set

Busy	<ul style="list-style-type: none"> <li>• In process of camera initializing operation by <b>Camera Reset</b> command, etc.</li> <li>• In process of zooming operation.</li> <li>• In process of focus operation by manual.</li> <li>• In case of executing <b>Preset Move</b> command.</li> </ul>
Mode Error	<ul style="list-style-type: none"> <li>• Not in status of <b>Camera ON</b>.</li> <li>• Not in status of <b>Host Control Mode</b>.</li> </ul>



### 13.13 Zoom Tele

Function	Move the zoom to TELE side at the selected zoom speed (0-7).	
Command	00A2h	
Parameter	Length	1 byte
	Value	2h
Status	None	
Reference	<ul style="list-style-type: none"> <li>• <b>Flags in Zooming of Operation Status Request</b> comes out 1.</li> <li>• Possible to stop running by <b>Zoom Stop</b> command.</li> <li>• To stop running at the zoom operation limit point (Tele), and <b>Flag in Zooming</b> comes out zero.</li> <li>• To return notification at the moment of reaching to zoom operation limit point (Tele).</li> </ul> <p>Note: When zoom position reached to the zoom operation limit position of tele end, <b>Flag in Zooming</b> doesn't come out 1 because of not zoom running.</p>	

● Format of Control Code

d0	d1	d2	d3	d4	d5	d6
Header	Device Num		Command		Parameter	End mark
FFh	30h	3Xh	00h	A2h	32h	EFh

● Answer Format

d0	d1	d2	d3	d4	d5
Header	Device Num		Error Code		End mark
FEh	30h	3Xh	e0	e1	EFh



Error Flag indicates in 2 figures hexadecimal and returns ASCII code value.	
Example:	e0 e1
■ In case of No Error :	00000000B ⇒ 00h ⇒ 30h 30h
■ In case of Busy :	00010000B ⇒ 10h ⇒ 31h 30h
■ In case of Mode Error :	10010000B ⇒ 90h ⇒ 39h 30h

● Condition of Error flag to be set

Busy	<ul style="list-style-type: none"> <li>• In process of camera initializing operation by <b>Camera Reset</b> command, etc.</li> <li>• In process of zooming operation.</li> <li>• In process of focus operation by manual</li> <li>• In case of executing <b>Preset Move</b> command.</li> </ul>
Mode Error	<ul style="list-style-type: none"> <li>• Not in status of <b>Camera ON</b>.</li> <li>• Not in status of <b>Host Control Mode</b>.</li> </ul>

### 13.14 Zoom Hi Wide

Camera Control Command Type 2

Function	Move the zoom to WIDE side at the zoom speed 7 (the maximum high speed).	
Command	00A2h	
Parameter	Length	1 byte
	Value	3h
Status	None	
Reference	<ul style="list-style-type: none"> <li>• <b>Flags in Zooming of Operation Status Request</b> comes out 1.</li> <li>• Possible to stop running by <b>Zoom Stop</b> command.</li> <li>• To stop running at the zoom operation limit point (Wide), and <b>Flag in Zooming</b> comes out zero.</li> <li>• To return notification at the moment of reaching to zoom operation limit point (Wide).</li> </ul> <p>Note: When zoom position reached to the zoom operation limit position of wide end, <b>Flag in Zooming</b> doesn't come out 1 because of not zoom running.</p>	

#### ● Format of Control Code

d0	d1	d2	d3	d4	d5	d6
Header	Device Num		Command		Parameter	End mark
FFh	30h	3Xh	00h	A2h	33h	EFh

#### ● Answer Format

d0	d1	d2	d3	d4	d5
Header	Device Num		Error Code		End mark
FEh	30h	3Xh	e0	e1	EFh



Error Flag indicates in 2 figures hexadecimal and returns ASCII code value.	
Example:	e0 e1
■ In case of No Error :	0000000B ⇒ 00h ⇒ 30h 30h
■ In case of Busy :	0001000B ⇒ 10h ⇒ 31h 30h
■ In case of Mode Error :	1001000B ⇒ 90h ⇒ 39h 30h

#### ● Condition of Error flag to be set

Busy	<ul style="list-style-type: none"> <li>• In process of camera initializing operation by <b>Camera Reset</b> command, etc.</li> <li>• In process of zooming operation.</li> <li>• In process of focus operation by manual.</li> <li>• In case of executing <b>Preset Move</b> command.</li> </ul>
Mode Error	<ul style="list-style-type: none"> <li>• Not in status of <b>Camera ON</b>.</li> <li>• Not in status of <b>Host Control Mode</b>.</li> </ul>

### 13.15 Zoom Hi Tele

### Camera Control Command Type 2

Function	Move the zoom to TELE side at the zoom speed 7 (the maximum high speed).	
Command	00A2h	
Parameter	Length	1 byte
	Value	4h
Status	None	
Reference	<ul style="list-style-type: none"> <li>• <b>Flags in Zooming of Operation Status Request</b> comes out 1.</li> <li>• Possible to stop running by <b>Zoom Stop</b> command</li> <li>• To stop running at the zoom operation limit point (Tele), and <b>Flag in Zooming</b> comes out zero.</li> <li>• To return notification at the moment of reaching to zoom operation limit point (Tele).</li> </ul> <p>Note: When zoom position reached to the zoom operation limit position of tele end, <b>Flag in Zooming</b> doesn't come out 1 because of not zoom running.</p>	

#### ● Format of Control Code

d0	d1	d2	d3	d4	d5	d6
Header	Device Num		Command		Parameter	End mark
FFh	30h	3Xh	00h	A2h	34h	EFh

#### ● Answer Format

d0	d1	d2	d3	d4	d5
Header	Device Num		Error Code		End mark
FEh	30h	3Xh	e0	e1	EFh



Error Flag indicates in 2 figures hexadecimal and returns ASCII code value.	
Example:	e0 e1
■ In case of No Error :	00000000B ⇒ 00h ⇒ 30h 30h
■ In case of Busy :	00010000B ⇒ 10h ⇒ 31h 30h
■ In case of Mode Error :	10010000B ⇒ 90h ⇒ 39h 30h

#### ● Condition of Error flag to be set

Busy	<ul style="list-style-type: none"> <li>• In process of camera initializing operation by <b>Camera Reset</b> command, etc.</li> <li>• In process of zooming operation.</li> <li>• In process of focus operation by manual.</li> <li>• In case of executing <b>Preset Move</b> command.</li> </ul>
Mode Error	<ul style="list-style-type: none"> <li>• Not in status of <b>Camera ON</b>.</li> <li>• Not in status of <b>Host Control Mode</b>.</li> </ul>

### 13.16 Zoom Position 1 Assignment

### Camera Control Command Type 2

Function	To move to zoom position assigned.	
Command	00A3h	
Parameter	Length	2 byte
	Range	00h (Wide End)~80h (Tele End)
Status	None	
Reference	<ul style="list-style-type: none"> <li>•To assign zoom position by pre-assigned step value, within movable range.</li> <li>•<b>Flags in Zooming of Operation Status Request</b> comes out 1. Zooming will stop after moving assigned position and <b>Flag in Zooming</b> comes 0.</li> <li>•To stop zooming by <b>Zoom Stop</b> command and flag in zooming comes out zero.</li> <li>•To return notification at the moment of setting command termination notification after reaching to assigned position. But not to return notification, when zooming stops by <b>Zoom Stop</b> command before reaching assigned position.</li> </ul>	

#### ● Format of Control Code

d0	d1	d2	d3	d4	d5	d6	d7
Header	Device Num		Command		Parameter		End mark
FFh	30h	3Xh	00h	A3h	p0	p1	EFh



Zoom position indicates in hexadecimal 2 figures and parameter value is its ASCII code.				
Example:				
64	⇒	40h	⇒	p0 p1 34h 30h

#### ● Answer Format

d0	d1	d2	d3	d4	d5
Header	Device Num		Error Code		End mark
FEh	30h	3Xh	e0	e1	EFh



Error Flag indicates in 2 figures hexadecimal and returns ASCII code value.				
Example:				
■ In case of No Error :	00000000B	⇒	00h	⇒ 30h 30h
■ In case of Busy :	00010000B	⇒	10h	⇒ 31h 30h
■ In case of Parameter Error :	01010000B	⇒	50h	⇒ 35h 30h
■ In case of Mode Error :	10010000B	⇒	90h	⇒ 39h 30h

#### ● Condition of Error flag to be set

Busy	<ul style="list-style-type: none"> <li>•In process of camera initializing operation by <b>Camera Reset</b> command, etc.</li> <li>•In process of zooming operation.</li> <li>•In process of focus operation by manual.</li> <li>•In case of executing <b>Preset Move</b> command.</li> </ul>
Parameter Error	•In case of assigned parameter over value to upper and lower.
Mode Error	<ul style="list-style-type: none"> <li>•Not in status of <b>Camera ON</b>.</li> <li>•Not in status of <b>Host Control Mode</b>.</li> </ul>



### 13.18 Zoom Position 2 Assignment

### Camera Control Command Type 2

Function	To move to zoom position assigned.		
Command	00B3h		
Parameter	Length	4 byte	
	Range	Min. Value: 0000h (Wide End)	
		Max. Value: 07A8h (Tele End)	
Status	None		
Reference	<ul style="list-style-type: none"> <li>•To assign zoom position in effective value.</li> <li>•<b>Flags in Zooming of Operation Status Request</b> comes out 1. Zooming will stop after moving assigned position and <b>Flag in Zooming</b> comes 0.</li> <li>•To stop zooming by <b>Zoom Stop</b> command and <b>Flag in Zooming</b> comes out zero.</li> <li>•To return notification at the moment of setting command termination notification after reaching to assigned position. But not to return notification, when zooming stops by <b>Zoom Stop</b> command before reaching assigned position.</li> </ul>		

#### ● Format of Control Code

	d0	d1	d2	d3	d4	d5	d6	d7	d8	d9
Header	Device Num		Command		Parameter				End mark	
FFh	30h	3Xh	00h	B3h	p0	p1	p2	p3	EFh	



Zoom position indicates in hexadecimal 4 figures and its ASCII code is parameter value.							
Example:							
256	⇒	0100h	⇒	p0	p1	p2	p3
				30h	31h	30h	30h

#### ● Answer Format

	d0	d1	d2	d3	d4	d5
Header	Device Num		Error Code		End mark	
FEh	30h	3Xh	e0	e1	EFh	



Error Flag indicates in 2 figures hexadecimal and returns ASCII code value.					
Example:					
■ In case of No Error :	0000000B	⇒	00h	⇒	30h 30h
■ In case of Busy :	0001000B	⇒	10h	⇒	31h 30h
■ In case of Parameter Error :	0101000B	⇒	50h	⇒	35h 30h
■ In case of Mode Error :	1001000B	⇒	90h	⇒	39h 30h

#### ● Condition of Error flag to be set

Busy	<ul style="list-style-type: none"> <li>•In process of camera initializing operation by <b>Camera Reset</b> command, etc.</li> <li>•In process of zooming operation.</li> <li>•In process of focus operation by manual.</li> <li>•In case of executing <b>Preset Move</b> command.</li> </ul>
Parameter Error	•In case of assigned parameter over value to upper.
Mode Error	<ul style="list-style-type: none"> <li>•Not in status of <b>Camera ON</b>.</li> <li>•Not in status of <b>Host Control Mode</b>.</li> </ul>

### 13.19 Zoom Position 2 Request

Camera Control Command Type 1

Function	To return present zoom position.	
Command	00B4h	
Parameter	Length	1 byte
	Value	0h
Status	Length	4 byte
	Range	Min. Value: 0000h (Wide End)
		Max. Value: 07A8h (Tele End)
Reference	<ul style="list-style-type: none"> <li>•To assign zoom position in effective value.</li> <li>•Possibly error will be within <math>\pm 5\%</math> before executing <b>Camera Reset</b> command and <b>Camera ON</b> command or after returning camera.</li> </ul>	

● Format of Control Code

d0	d1	d2	d3	d4	d5	d6
Header	Device Num		Command		Parameter	End mark
FFh	30h	3Xh	00h	B4h	30h	EFh

● Answer Format

■ In case of No Error

d0	d1	d2	d3	d4	d5	d6	d7	d8	d9
Header	Device Num		Error Code		Zoom Position				End mark
FEh	30h	3Xh	30h	30h	s0	s1	s2	s3	EFh



Present position indicates in hexadecimal 4 figures and its ASCII code is Status value.									
Example:									
256	⇒	0100h	⇒	s0	s1	s2	s3		
				30h	31h	30h	30h		

■ In case of Error

d0	d1	d2	d3	d4	d5
Header	Device Num		Error Code		End mark
FEh	30h	3Xh	e0	e1	EFh



Error Flag indicates in 2 figures hexadecimal and returns ASCII code value.					
Example:					
				e0	e1
■ In case of Busy :	00010000B	⇒	10h	⇒	31h 30h
■ In case of Mode Error :	10010000B	⇒	90h	⇒	39h 30h

● Condition of Error flag to be set

Busy	<ul style="list-style-type: none"> <li>•In process of camera initializing operation by <b>Camera Reset</b> command, etc.</li> <li>•In case of executing <b>Preset Move</b> command.</li> </ul>
Mode Error	<ul style="list-style-type: none"> <li>•Not in status of <b>Camera ON</b>.</li> <li>•Not in status of <b>Host Control Mode</b>.</li> </ul>

### 13.20 Zoom Speed Assignment

Camera Control Command Type 1

Function	To assign zooming speed.	
Command	00B4h	
Parameter	Length	2 byte, including "31h" (fixed value)
	Range	0~7
Status	None	
Reference	<ul style="list-style-type: none"> <li>•Speed set by this command is reflected in <b>Zoom Wide</b>, <b>Zoom Tele</b>, <b>Zoom Position Assignment</b> and <b>Preset Move</b>.</li> <li>•Default value is 7.</li> </ul>	

#### ● Format of Control Code

d0	d1	d2	d3	d4	d5	d6	d7
Header	Device Num		Command		Parameter		End mark
FFh	30h	3Xh	00h	B4h	31h	p1	EFh



Zoom speed indicates in hexadecimal 1 figure and parameter value is its ASCII code.	
Example:	4 ⇒ 4h ⇒ p0 34h

#### ● Answer Format

d0	d1	d2	d3	d4	d5
Header	Device Num		Error Code		End mark
FEh	30h	3Xh	e0	e1	EFh



Error Flag indicates in 2 figures hexadecimal and returns ASCII code value.	
Example:	e0 e1
■ In case of No Error :	0000000B ⇒ 00h ⇒ 30h 30h
■ In case of Busy :	00010000B ⇒ 10h ⇒ 31h 30h
■ In case of Parameter Error :	01010000B ⇒ 50h ⇒ 35h 30h
■ In case of Mode Error :	10010000B ⇒ 90h ⇒ 39h 30h

#### ● Condition of Error flag to be set

Busy	<ul style="list-style-type: none"> <li>•In process of camera initializing operation by <b>Camera Reset</b> command, etc.</li> <li>•In case of executing <b>Preset Move</b> command.</li> </ul>
Parameter Error	•In case of out of range of assigned parameter.
Mode Error	<ul style="list-style-type: none"> <li>•Not in status of <b>Camera ON</b>.</li> <li>•Not in status of <b>Host Control Mode</b>.</li> </ul>



### 13.21 Zoom Speed Request

Camera Control Command Type 1

Function	To return present zooming speed.	
Command	00B4h	
Parameter	Length	1 byte
	Value	2h
Status	Length	1 byte
	Range	0~7
Reference	•Default value is 7.	

● Format of Control Code

d0	d1	d2	d3	d4	d5	d6
Header	Device Num		Command		Parameter	End mark
FFh	30h	3Xh	00h	B4h	32h	EFh

● Answer Format

■ In case of No Error

d0	d1	d2	d3	d4	d5	d6
Header	Device Num		Error Code		Speed	End mark
FEh	30h	3Xh	30h	30h	s0	EFh



Zoom speed indicates in hexadecimal 1 figure and status value is its ASCII code.		
Example:		s0
4	⇒	4h ⇒ 34h

■ In case of Error

d0	d1	d2	d3	d4	d5
Header	Device Num		Error Code		End mark
FEh	30h	3Xh	e0	e1	EFh



Error Flag indicates in 2 figures hexadecimal and returns ASCII code value.		
Example:		e0 e1
■ In case of Busy :	00010000B ⇒ 10h	⇒ 31h 30h
■ In case of Mode Error :	10010000B ⇒ 90h	⇒ 39h 30h

● Condition of Error flag to be set

Busy	<ul style="list-style-type: none"> <li>•In process of camera initializing operation by <b>Camera Reset</b> command, etc.</li> <li>•In case of executing <b>Preset Move</b> command.</li> </ul>
Mode Error	<ul style="list-style-type: none"> <li>•Not in status of <b>Camera ON</b>.</li> <li>•Not in status of <b>Host Control Mode</b>.</li> </ul>

### 13.22 Zoom Position Maximum Request

Camera Control Command Type 1

Function	To return maximum value of zoom position.	
Command	00B4h	
Parameter	Length	1 byte
	Value	3h
Status	Length	4 byte
	Value	0000h~07A8h
Reference	•To return movable max. value of zoom position.	

● Format of Control Code

d0	d1	d2	d3	d4	d5	d6
Header	Device Num		Command		Parameter	End mark
FFh	30h	3Xh	00h	B4h	33h	EFh

● Answer Format

■ In case of No Error

d0	d1	d2	d3	d4	d5	d6	d7	d8	d9
Header	Device Num		Error Code		Zoom Movable Max. Value				End mark
FEh	30h	3Xh	30h	30h	s0	s1	s2	s3	EFh



Zoom maximum value indicates in hexadecimal 4 figures and its ASCII code is status value.							
Example:							
2142	⇒	085Eh	⇒	s0	s1	s2	s3
				30h	38h	35h	45h

■ In case of Error

d0	d1	d2	d3	d4	d5
Header	Device Num		Error Code		End mark
FEh	30h	3Xh	e0	e1	EFh



Error Flag indicates in 2 figures hexadecimal and returns ASCII code value.					
Example:					
e0 e1					
■ In case of Busy :		00010000B	⇒	10h	⇒ 31h 30h
■ In case of Mode Error :		10010000B	⇒	90h	⇒ 39h 30h

● Condition of Error flag to be set

Busy	<ul style="list-style-type: none"> <li>•In process of camera initializing operation by <b>Camera Reset</b> command, etc.</li> <li>•In case of executing <b>Preset Move</b> command.</li> </ul>
Mode Error	<ul style="list-style-type: none"> <li>•Not in status of <b>Camera ON</b>.</li> <li>•Not in status of <b>Host Control Mode</b>.</li> </ul>

### 13.23 Backlight Compensation OFF

Function	To change to backlight non-compensation mode.	
Command	00A5h	
Parameter	Length	1 byte
	Value	0h
Status	None	
Reference	<ul style="list-style-type: none"> <li>•To receive command at Auto exposure mode.</li> <li>•To operate identical operation as to assign 48h by <b>AE Target Value Assignment</b> command.</li> <li>•To be set by default at the moment of executing <b>Camera Reset</b> command</li> <li>•At the moment of command termination notification ON setting, to return notification, when operation finished. But when <b>Backlight Compensation ON</b>, <b>AE Target Value Assignment</b> command are executing, not to return notification of <b>Backlight Compensation OFF</b>.</li> </ul>	

● Format of Control Code

d0	d1	d2	d3	d4	d5	d6
Header	Device Num		Command		Parameter	End mark
FFh	30h	3Xh	00h	A5h	30h	EFh

● Answer Format

d0	d1	d2	d3	d4	d5
Header	Device Num		Error Code		End mark
FEh	30h	3Xh	e0	e1	EFh



Error Flag indicates in 2 figures hexadecimal and returns ASCII code value.					
Example:					
■ In case of No Error :	00000000B	⇒	00h	⇒	e0 e1 30h 30h
■ In case of Busy :	00010000B	⇒	10h	⇒	31h 30h
■ In case of Mode Error :	10010000B	⇒	90h	⇒	39h 30h

● Condition of Error flag to be set

Busy	<ul style="list-style-type: none"> <li>•In process of camera initializing operation by <b>Camera Reset</b> command, etc.</li> <li>•In case of exposure manual mode.</li> <li>•In status of AE Lock ON.</li> <li>•In case of executing <b>Preset Move</b> command.</li> </ul>
Mode Error	<ul style="list-style-type: none"> <li>•Not in status of <b>Camera ON</b></li> <li>•Not in status of <b>Host Control Mode</b></li> </ul>

### 13.24 Backlight Compensation ON

Camera Control Command Type 2

Function	To change to backlight compensation mode.	
Command	00A5h	
Parameter	Length	1 byte
	Value	1h
Status	None	
Reference	<ul style="list-style-type: none"> <li>•To receive command at auto exposure mode.</li> <li>•The same operation is performed as when 90h (1.5 aperture open) is designated by the <b>AE Target Value Assignment</b> command. For the other correction values, refer to the description of <b>AE Target Value Assignment</b>.</li> <li>•At the moment of command termination notification ON setting, to return notification, when operation finished. But when <b>Backlight Compensation OFF</b>, <b>AE Target Value Assignment</b> command are executing, not to return notification of <b>Backlight Compensation ON</b>.</li> </ul>	

● Format of Control Code

d0	d1	d2	d3	d4	d5	d6
Header	Device Num		Command		Parameter	End mark
FFh	30h	3Xh	00h	A5h	31h	EFh

● Answer Format

d0	d1	d2	d3	d4	d5
Header	Device Num		Error Code		End mark
FEh	30h	3Xh	e0	e1	EFh



Error Flag indicates in 2 figures hexadecimal and returns ASCII code value.	
Example:	e0 e1
■ In case of No Error :	00000000B ⇒ 00h ⇒ 30h 30h
■ In case of Busy :	00010000B ⇒ 10h ⇒ 31h 30h
■ In case of Mode Error :	10010000B ⇒ 90h ⇒ 39h 30h

● Condition of Error flag to be set

Busy	<ul style="list-style-type: none"> <li>•In process of camera initializing operation by <b>Camera Reset</b> command, etc.</li> <li>•In case of exposure manual mode.</li> <li>•In status of AE Lock ON.</li> <li>•In case of executing <b>Preset Move</b> command.</li> </ul>
Mode Error	<ul style="list-style-type: none"> <li>•Not in status of <b>Camera ON</b>.</li> <li>•Not in status of <b>Host Control Mode</b>.</li> </ul>

### 13.25 Exposure Automatic

Camera Control Command Type 1

Function	To change to exposure auto mode.	
Command	00A5h	
Parameter	Length	1 byte
	Value	2h
Status	None	
Reference	<ul style="list-style-type: none"> <li>•The related exposure commands which enable to set in auto exposure mode, are <b>Backlight Compensation ON/OFF</b>, <b>Shutter Speed Program</b>, <b>Shutter Speed 1/60, 1/100</b> and <b>AE Target Value Assignment</b>.</li> <li>•Default value is set at the moment of executing <b>Camera Reset</b> and <b>Camera ON</b> command during power ON.</li> </ul>	

● Format of Control Code

d0	d1	d2	d3	d4	d5	d6
Header	Device Num		Command		Parameter	End mark
FFh	30h	3Xh	00h	A5h	32h	EFh

● Answer Format

d0	d1	d2	d3	d4	d5
Header	Device Num		Error Code		End mark
FEh	30h	3Xh	e0	e1	EFh



Error Flag indicates in 2 figures hexadecimal and returns ASCII code value.	
Example:	e0 e1
■ In case of No Error :	00000000B ⇒ 00h ⇒ 30h 30h
■ In case of Busy :	00010000B ⇒ 10h ⇒ 31h 30h
■ In case of Mode Error :	10010000B ⇒ 90h ⇒ 39h 30h

● Condition of Error flag to be set

Busy	<ul style="list-style-type: none"> <li>•In process of camera initializing operation by <b>Camera Reset</b> command, etc.</li> <li>•In case of executing <b>Preset Move</b> command.</li> </ul>
Mode Error	<ul style="list-style-type: none"> <li>•Not in status of <b>Camera ON</b>.</li> <li>•Not in status of <b>Host Control Mode</b>.</li> </ul>

### 13.26 Exposure Manual

### Camera Control Command Type 1

Function	To change to exposure manual mode.	
Command	00A5h	
Parameter	Length	1 byte
	Value	3h
Status	None	
Reference	<ul style="list-style-type: none"> <li>The related exposure commands which enable to set in manual exposure mode, are <b>Shutter Speed Assignment</b>, <b>AGC Gain Assignment</b> and <b>Iris Assignment</b>.</li> </ul>	

#### ● Format of Control Code

d0	d1	d2	d3	d4	d5	d6
Header	Device Num		Command		Parameter	End mark
FFh	30h	3Xh	00h	A5h	33h	EFh

#### ● Answer Format

d0	d1	d2	d3	d4	d5
Header	Device Num		Error Code		End mark
FEh	30h	3Xh	e0	e1	EFh



Error Flag indicates in 2 figures hexadecimal and returns ASCII code value	
Example:	e0 e1
■ In case of No Error :	00000000B ⇒ 00h ⇒ 30h 30h
■ In case of Busy :	00010000B ⇒ 10h ⇒ 31h 30h
■ In case of Mode Error :	10010000B ⇒ 90h ⇒ 39h 30h

#### ● Condition of Error flag to be set

Busy	<ul style="list-style-type: none"> <li>In process of camera initializing operation by <b>Camera Reset</b> command, etc.</li> <li>In status of AE Lock ON.</li> <li>In case of executing <b>Preset Move</b> command.</li> </ul>
Mode Error	<ul style="list-style-type: none"> <li>Not in status of <b>Camera ON</b>.</li> <li>Not in status of <b>Host Control Mode</b>.</li> </ul>

### 13.27 AE Lock OFF

Camera Control Command Type 1

Function	To cancel AE Lock ON status.	
Command	00A5h	
Parameter	Length	2 byte
	Value	40h
Status	None	
Reference	<ul style="list-style-type: none"> <li>•To set auto exposure mode ON.</li> <li>•Default value is set at the moment of executing <b>Camera Reset</b> and <b>Camera ON</b> command during power ON.</li> </ul>	

#### ● Format of Control Code

d0	d1	d2	d3	d4	d5	d6	d7
Header	Device Num		Command		Parameter		End mark
FFh	30h	3Xh	00h	A5h	34h	30h	EFh

#### ● Answer Format

d0	d1	d2	d3	d4	d5
Header	Device Num		Error Code		End mark
FEh	30h	3Xh	e0	e1	EFh



Error Flag indicates in 2 figures hexadecimal and returns ASCII code value.	
Example:	e0 e1
■ In case of No Error :	0000000B ⇒ 00h ⇒ 30h 30h
■ In case of Busy :	00010000B ⇒ 10h ⇒ 31h 30h
■ In case of Mode Error :	10010000B ⇒ 90h ⇒ 39h 30h

#### ● Condition of Error flag to be set

Busy	<ul style="list-style-type: none"> <li>•In process of camera initializing operation by <b>Camera Reset</b> command, etc.</li> <li>•In status of exposure mode manual.</li> <li>•In case of executing <b>Preset Move</b> command.</li> </ul>
Mode Error	<ul style="list-style-type: none"> <li>•Not in status of <b>Camera ON</b>.</li> <li>•Not in status of <b>Host Control Mode</b>.</li> </ul>

### 13.28 AE Lock ON

Function	To lock the exposure of AE mode.	
Command	00A5h	
Parameter	Length	2 byte
	Value	41h
Status	None	
Reference	•To set in status to disapprove exposure setting value.	

● Format of Control Code

d0	d1	d2	d3	d4	d5	d6	d7
Header	Device Num		Command		Parameter		End mark
FFh	30h	3Xh	00h	A5h	34h	31h	EFh

● Answer Format

d0	d1	d2	d3	d4	d5
Header	Device Num		Error Code		End mark
FEh	30h	3Xh	e0	e1	EFh



Error Flag indicates in 2 figures hexadecimal and returns ASCII code value.		
Example:		e0 e1
■ In case of No Error :	00000000B ⇒ 00h ⇒	30h 30h
■ In case of Busy :	00010000B ⇒ 10h ⇒	31h 30h
■ In case of Mode Error :	10010000B ⇒ 90h ⇒	39h 30h

● Condition of Error flag to be set

Busy	<ul style="list-style-type: none"> <li>•In process of camera initializing operation by <b>Camera Reset</b> command, etc.</li> <li>•In status of exposure mode manual.</li> <li>•In case of executing <b>Preset Move</b> command.</li> </ul>
Mode Error	<ul style="list-style-type: none"> <li>•Not in status of <b>Camera ON</b>.</li> <li>•Not in status of <b>Host Control Mode</b>.</li> </ul>

In status of Exposure Mode Changeable

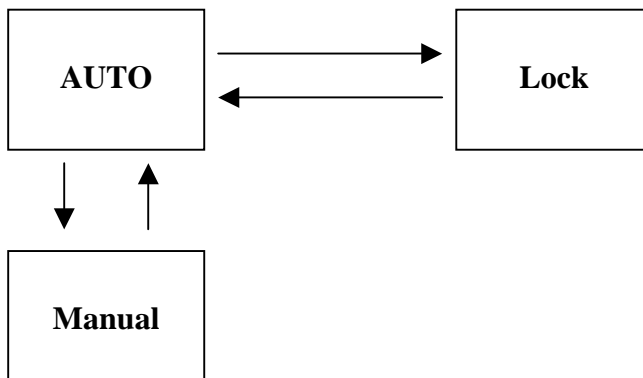



### 13.29 Shutter Speed Program

Camera Control Command Type 1

Function	To change shutter speed to program mode.	
Command	00A8h	
Parameter	Length	1 byte
	Value	0h
Status	None	
Reference	<ul style="list-style-type: none"> <li>•To change shutter speed automatically at the moment of Hi luminance shot and prevent resolution from lowering by small iris diffraction</li> <li>•To receive command at auto exposure mode.</li> <li>•To be set by default at the moment of executing <b>Camera Reset</b> command.</li> </ul>	

● Format of Control Code

	d0	d1	d2	d3	d4	d5	d6
Header	Device Num		Command		Parameter	End mark	
FFh	30h	3Xh	00h	A8h	30h	EFh	

● Answer Format

	d0	d1	d2	d3	d4	d5
Header	Device Num		Error Code		End mark	
FEh	30h	3Xh	e0	e1	EFh	



Error Flag indicates in 2 figures hexadecimal and returns ASCII code value.	
Example:	e0 e1
■ In case of No Error :	00000000B ⇒ 00h ⇒ 30h 30h
■ In case of Busy :	00010000B ⇒ 10h ⇒ 31h 30h
■ In case of Mode Error :	10010000B ⇒ 90h ⇒ 39h 30h

● Condition of Error flag to be set

Busy	<ul style="list-style-type: none"> <li>•In process of camera initializing operation by <b>Camera Reset</b> command, etc.</li> <li>•In status of exposure mode manual.</li> <li>•In status of AE Lock ON.</li> <li>•In case of executing <b>Preset Move</b> command.</li> </ul>
Mode Error	<ul style="list-style-type: none"> <li>•Not in status of <b>Camera ON</b>.</li> <li>•Not in status of <b>Host Control Mode</b>.</li> </ul>

### 13.30 Shutter Speed 1/60 (PAL:1/50)

Camera Control Command Type 2

Function	To change shutter speed to 1/60 (PAL: 1/50) mode.	
Command	00A8h	
Parameter	Length	1 byte
	Value	1h
Status	None	
Reference	<ul style="list-style-type: none"> <li>•To receive command at the moment of exposure mode auto.</li> <li>•To return notification at the moment of setting command termination notification ON, when operation terminates. But not return notification of <b>Shutter Speed 1/60</b> command, in case of executing <b>Shutter Speed Program, Shutter Speed 1/100</b> during operation.</li> </ul>	

● Format of Control Code

d0	d1	d2	d3	d4	d5	d6
Header	Device Num		Command		Parameter	End mark
FFh	30h	3Xh	00h	A8h	31h	EFh

● Answer Format

d0	d1	d2	d3	d4	d5
Header	Device Num		Error Code		End mark
FEh	30h	3Xh	e0	e1	EFh

↓

Error Flag indicates in 2 figures hexadecimal and returns ASCII code value.	
Example:	e0 e1
■ In case of No Error :	0000000B ⇒ 00h ⇒ 30h 30h
■ In case of Busy :	0001000B ⇒ 10h ⇒ 31h 30h
■ In case of Mode Error :	1001000B ⇒ 90h ⇒ 39h 30h

● Condition of Error flag to be set

Busy	<ul style="list-style-type: none"> <li>•In process of camera initializing operation by <b>Camera Reset</b> command, etc.</li> <li>•In status of exposure mode manual.</li> <li>•In status of AE Lock ON.</li> <li>•In case of executing <b>Preset Move</b> command.</li> </ul>
Mode Error	<ul style="list-style-type: none"> <li>•Not in status of <b>Camera ON</b>.</li> <li>•Not in status of <b>Host Control Mode</b>.</li> </ul>

### 13.31 Shutter Speed 1/100 (PAL:1/120)

Camera Control Command Type 2

Function	To change shutter speed to 1/100 (PAL: 1/120) mode.	
Command	00A8h	
Parameter	Length	1 byte
	Value	2h
Status	None	
Reference	<ul style="list-style-type: none"> <li>•To be able to lower flicker.</li> <li>•To receive command at the moment of exposure mode auto.</li> <li>•To return notification at the moment of setting command termination notification ON, when operation terminates. But not return notification of <b>Shutter Speed 1/100</b> command, in case of executing <b>Shutter Speed Program, Shutter Speed 1/60</b> during operation.</li> </ul>	

#### ● Format of Control Code

d0	d1	d2	d3	d4	d5	d6
Header	Device Num		Command		Parameter	End mark
FFh	30h	3Xh	00h	A8h	32h	EFh

#### ● Answer Format

d0	d1	d2	d3	d4	d5
Header	Device Num		Error Code		End mark
FEh	30h	3Xh	e0	e1	EFh



Error Flag indicates in 2 figures hexadecimal and returns ASCII code value.	
Example:	e0 e1
■ In case of No Error :	00000000B ⇒ 00h ⇒ 30h 30h
■ In case of Busy :	00010000B ⇒ 10h ⇒ 31h 30h
■ In case of Mode Error :	10010000B ⇒ 90h ⇒ 39h 30h

#### ● Condition of Error flag to be set

Busy	<ul style="list-style-type: none"> <li>•In process of camera initializing operation by <b>Camera Reset</b> command, etc.</li> <li>•In status of exposure mode manual.</li> <li>•In status of AE Lock ON.</li> <li>•In case of executing <b>Preset Move</b> command.</li> </ul>
Mode Error	<ul style="list-style-type: none"> <li>•Not in status of <b>Camera ON</b>.</li> <li>•Not in status of <b>Host Control Mode</b>.</li> </ul>

### 13.32 Shutter Speed Assignment

Function	To assign shutter speed.	
Command	00A5h	
Parameter	Length	3 byte, including fixed value (35h).
	Range	00h~1Bh or 80h~83h
Status	None	
Reference	<ul style="list-style-type: none"> <li>Specify with the phase value assigned in [1/80000seconds - 1/60seconds( PAL:one/50seconds) - 1seconds]. See Shutter Speed Corresponding Table.</li> <li>To receive command at the moment of exposure mode manual.</li> <li>To return notification at the moment of setting command termination notification ON, when operation terminates. But not return notification in case of changing exposure mode to auto during operation.</li> <li>When the low-speed shutter is specified, the noise reduction is automatically canceled, and select the focus automatically to the manual focus (NTSC:1/30, and PAL:1/25 exclude), and it selects the white balance automatically to the manual white balance. Thereafter, when returning to the high-speed shutter, it returns to the set of the origin of the before the shift.</li> </ul>	

•At the low-speed shutter time (80h-83h) , can be changed only to high-speed shutter (00h – 1Bh).

● Format of Control Code

d0	d1	d2	d3	d4	d5	d6	d7	d8
Header	Device Num		Command		Parameter			End mark
FFh	30h	3Xh	00h	A5h	35h	p1	p2	EFh



Shutter Speed Parameter indicates in hexadecimal 2 figures and parameter value is its ASCII code.					
Example:	10	⇒	0Ah ⇒	p1	p2
				30h	41h

● Answer Format

d0	d1	d2	d3	d4	d5
Header	Device Num		Error Code		End mark
FEh	30h	3Xh	e0	e1	EFh



Error Flag indicates in 2 figures hexadecimal and returns ASCII code value.					
Example:				e0	e1
■ In case of No Error :	0000000B	⇒	00h	⇒	30h 30h
■ In case of Busy :	0001000B	⇒	10h	⇒	31h 30h
■ In case of Parameter Error :	0101000B	⇒	50h	⇒	35h 30h
■ In case of Mode Error :	1001000B	⇒	90h	⇒	39h 30h

● Condition of Error flag to be set

Busy	<ul style="list-style-type: none"> <li>•In process of camera initializing operation by <b>Camera Reset</b> command, etc.</li> <li>•In status of exposure mode auto.</li> <li>•In status of AE Lock ON.</li> <li>•In case of executing <b>Preset Move</b> command.</li> </ul>
Parameter Error	<ul style="list-style-type: none"> <li>•In case of assigned parameter out of range.</li> <li>•When the low-speed is set out at the low speed.</li> </ul>
Mode Error	<ul style="list-style-type: none"> <li>•Not in status of <b>Camera ON</b>.</li> <li>•Not in status of <b>Host Control Mode</b>.</li> <li>• When the low-speed shutter is specified at the time of the Digital zoom mode.</li> </ul>

### 13.33 Shutter Speed Request

Camera Control Command Type 1

Function	To return present shutter speed.	
Command	00A5h	
Parameter	Length	1 byte
	Value	6h
Status	Length	2 byte
	Range	00h~1Bh or 80h~83h
Reference	<ul style="list-style-type: none"> <li>To return the phase value assigned in [1/80000seconds - 1/60seconds( PAL:one/50seconds) - 1seconds].</li> </ul> See Shutter Speed Corresponding Table.	

● Format of Control Code

d0	d1	d2	d3	d4	d5	d6
Header	Device Num		Command		Parameter	End mark
FFh	30h	3Xh	00h	A5h	36h	EFh

● Answer Format

■ In case of No Error

d0	d1	d2	d3	d4	d5	d6	d7
Header	Device Num		Error Code		Shutter Speed		End mark
FEh	30h	3Xh	30h	30h	s0	s1	EFh



Shutter Speed Parameter indicates in hexadecimal 2 figures and its ASCII Code is status value.

Example:					s0	s1
	10	⇒	0Ah	⇒	30h	41h

■ In case of Error

d0	d1	d2	d3	d4	d5
Header	Device Num		Error Code		End mark
FEh	30h	3Xh	e0	e1	EFh



Error Flag indicates in 2 figures hexadecimal and returns ASCII code value.

Example:					e0	e1
■ In case of Busy :	00010000B	⇒	10h	⇒	31h	30h
■ In case of Mode Error :	10010000B	⇒	90h	⇒	39h	30h

● Condition of Error flag to be set

Busy	<ul style="list-style-type: none"> <li>In process of camera initializing operation by <b>Camera Reset</b> command, etc.</li> <li>In case of executing <b>Preset Move</b> command.</li> </ul>
Mode Error	<ul style="list-style-type: none"> <li>Not in status of <b>Camera ON</b>.</li> <li>Not in status of <b>Host Control Mode</b>.</li> </ul>

•Shutter Speed Corresponding Table

High-speed shutter			Low-speed shutter				
Parameter	NTSC	PAL	Parameter	NTSC		PAL	
	Shutter Speed	Shutter Speed		Shutter Speed	Accumulated no. of fields	Shutter Speed	Accumulated no. of fields
00h	1/60	1/50	80h	1/30	2	1/25	2
01h	1/75	1/60	81h	1/8	7.5	1/6	8.3
02h	1/90	1/90	82h	1/2	30	1/2	25
03h	1/100	1/100	83h	1	60	1	50
04h	1/125	1/120					
05h	1/150	1/150					
06h	1/180	1/180					
07h	1/215	1/215					
08h	1/250	1/250					
09h	1/300	1/300					
0Ah	1/350	1/350					
0Bh	1/425	1/425					
0Ch	1/500	1/500					
0Dh	1/600	1/600					
0Eh	1/725	1/725					
0Fh	1/850	1/850					
10h	1/1000	1/1000					
11h	1/1250	1/1250					
12h	1/1500	1/1500					
13h	1/1750	1/1750					
14h	1/2000	1/2000					
15h	1/2500	1/2500					
16h	1/3000	1/3000					
17h	1/4000	1/4000					
18h	1/6000	1/6000					
19h	1/10000	1/10000					
1Ah	1/20000	1/20000					
1Bh	1/80000	1/80000					

### 13.34 AGC Gain Assignment

Function	To assign AGC gain.	
Command	00A5h	
Parameter	Length	3 byte, including fixed value (37h).
	Range	00h~FFh
Status	None	
Reference	<ul style="list-style-type: none"> <li>•To change AGC magnification.</li> <li>•To receive command at the moment of exposure mode manual.</li> </ul>	

● Format of Control Code

d0	d1	d2	d3	d4	d5	d6	d7	d8
Header	Device Num		Command		Parameter		End mark	
FFh	30h	3Xh	00h	A5h	37h	p1	p2	EFh



AGC Gain value indicates in hexadecimal 2 figures and parameter value is its ASCII code.				
Example:				
10	⇒	0Ah	⇒	p1 p2 30h 41h

● Answer Format

d0	d1	d2	d3	d4	d5
Header	Device Num		Error Code		End mark
FEh	30h	3Xh	e0	e1	EFh



Error Flag indicates in 2 figures hexadecimal and returns ASCII code value.				
Example:				
■ In case of No Error :	00000000B	⇒	00h	⇒ 30h 30h
■ In case of Busy :	00010000B	⇒	10h	⇒ 31h 30h
■ In case of Parameter Error :	01010000B	⇒	50h	⇒ 35h 30h
■ In case of Mode Error :	10010000B	⇒	90h	⇒ 39h 30h

● Condition of Error flag to be set

Busy	<ul style="list-style-type: none"> <li>•In process of camera initializing operation by <b>Camera Reset</b> command, etc.</li> <li>•In status of exposure mode auto.</li> <li>•In status of AE Lock ON.</li> <li>•In case of executing <b>Preset Move</b> command.</li> </ul>
Parameter Error	•In case of assigned parameter out of range.
Mode Error	<ul style="list-style-type: none"> <li>•Not in status of <b>Camera ON</b>.</li> <li>•Not in status of <b>Host Control Mode</b>.</li> </ul>



### 13.35 AGC Gain Request

Camera Control Command Type 1

Function	To return present AGC gain.	
Command	00A5h	
Parameter	Length	1 byte
	Value	8h
Status	Length	2 byte
	Range	00h~FFh
Reference		

● Format of Control Code

d0	d1	d2	d3	d4	d5	d6
Header	Device Num		Command		Parameter	End mark
FFh	30h	3Xh	00h	A5h	38h	EFh

● Answer Format

■ In case of No Error

d0	d1	d2	d3	d4	d5	d6	d7
Header	Device Num		Error Code		AGC Gain Value		End mark
FEh	30h	3Xh	30h	30h	s0	s1	EFh

↓

AGC gain value indicates in hexadecimal 2 figures and its ASCII code is Status value.
Example: <div style="display: flex; justify-content: space-around; align-items: center;"> <span>10</span> <span>⇒</span> <span>0Ah</span> <span>⇒</span> <span>s0</span> <span>s1</span> </div> <div style="display: flex; justify-content: space-around; align-items: center;"> <span>30h</span> <span>41h</span> </div>

■ In case of Error

d0	d1	d2	d3	d4	d5
Header	Device Num		Error Code		End mark
FEh	30h	3Xh	e0	e1	EFh

↓

Error Flag indicates in 2 figures hexadecimal and returns ASCII code value.
Example: <div style="display: flex; justify-content: space-between;"> <span>■ In case of Busy :</span> <span>00010000B ⇒ 10h ⇒ 31h 30h</span> </div> <div style="display: flex; justify-content: space-between;"> <span>■ In case of Mode Error :</span> <span>10010000B ⇒ 90h ⇒ 39h 30h</span> </div>

● Condition of Error flag to be set

Busy	<ul style="list-style-type: none"> <li>•In process of camera initializing operation by <b>Camera Reset</b> command, etc.</li> <li>•In case of executing <b>Preset Move</b> command.</li> </ul>
Mode Error	<ul style="list-style-type: none"> <li>•Not in status of <b>Camera ON</b>.</li> <li>•Not in status of <b>Host Control Mode</b>.</li> </ul>

### 13.36 Iris Assignment

Function	To assign iris.	
Command	00A5h	
Parameter	Length	3 byte, including fixed value (39h).
	Range	02h~11h
Status	None	
Reference	<ul style="list-style-type: none"> <li>•In case of decreasing a value to close iris and comes to darken.</li> <li>•In case of increasing a value to open iris and comes to brighten.</li> <li>•The assignable range is less narrow than the value returned by <b>Iris Request</b> command.</li> <li>•To receive a command, when exposure mode is manual mode.</li> <li>•When command termination notification is assigned ON, notification will be returned at the moment of the operation terminated during operation, exposure mode is changed to auto, notification will not be returned.</li> </ul>	

● Format of Control Code

d0	d1	d2	d3	d4	d5	d6	d7	d8
Header	Device Num		Command		Parameter			End mark
FFh	30h	3Xh	00h	A5h	39h	p1	p2	EFh



Iris value indicates in hexadecimal 2 figures and parameter value is its ASCII code.	
Example:	<p>10 ⇒ 0Ah ⇒ p1 p2</p> <p>30h 41h</p>

● Answer Format

d0	d1	d2	d3	d4	d5
Header	Device Num		Error Code		End mark
FEh	30h	3Xh	e0	e1	EFh



Error Flag indicates in 2 figures hexadecimal and returns ASCII code value.	
Example:	e0 e1
■ In case of No Error :	0000000B ⇒ 00h ⇒ 30h 30h
■ In case of Busy :	0001000B ⇒ 10h ⇒ 31h 30h
■ In case of Parameter Error :	0101000B ⇒ 50h ⇒ 35h 30h
■ In case of Mode Error :	1001000B ⇒ 90h ⇒ 39h 30h

● Condition of Error flag to be set

Busy	<ul style="list-style-type: none"> <li>•In process of camera initializing operation by <b>Camera Reset</b> command, etc.</li> <li>•In status of exposure mode auto.</li> <li>•In status of AE Lock ON.</li> <li>•In case of executing <b>Preset Move</b> command.</li> </ul>
Parameter Error	•In case of assigned parameter out of range.
Mode Error	<ul style="list-style-type: none"> <li>•Not in status of <b>Camera ON</b>.</li> <li>•Not in status of <b>Host Control Mode</b>.</li> </ul>

### 13.37 Iris Request

Function	To return present iris value.	
Command	00A5h	
Parameter	Length	1 byte
	Value	"3Ah" (Fixed value)
Status	Length	2 byte
	Range	00h~12h
Reference	•Outside range value assigned by <b>Iris Assignment</b> command might be returned, then status range is different from <b>Iris Assignment</b> command.	

● Format of Control Code

	d0	d1	d2	d3	d4	d5	d6
Header	Device Num		Command		Parameter	End mark	
FFh	30h	3Xh	00h	A5h	3Ah	EFh	

● Answer Format

■ In case of No Error

	d0	d1	d2	d3	d4	d5	d6	d7
Header	Device Num		Error Code		Iris Value		End mark	
FEh	30h	3Xh	30h	30h	s0	s1	EFh	



Iris value indicates in hexadecimal 2 figures and its ASCII code is Status value.	
Example:	s0    s1
10    ⇒    0Ah    ⇒    30h    41h	

■ In case of Error

	d0	d1	d2	d3	d4	d5
Header	Device Num		Error Code		End mark	
FEh	30h	3Xh	e0	e1	EFh	



Error Flag indicates in 2 figures hexadecimal and returns ASCII code value.	
Example:	e0    e1
■ In case of Busy :	00010000B ⇒ 10h ⇒ 31h 30h
■ In case of Mode Error :	10010000B ⇒ 90h ⇒ 39h 30h

● Condition of Error flag to be set

Busy	<ul style="list-style-type: none"> <li>•In process of camera initializing operation by <b>Camera Reset</b> command, etc.</li> <li>•In case of executing <b>Preset Move</b> command.</li> </ul>
Mode Error	<ul style="list-style-type: none"> <li>•Not in status of <b>Camera ON</b>.</li> <li>•Not in status of <b>Host Control Mode</b>.</li> </ul>

• Iris Value Table

00h	Close mechanically
01h	Close optically
02h	F16.0
03h	F13.3
04h	F11.0
05h	F9.4
06h	F8.0
07h	F6.7
08h	F5.6
09h	F4.7
0Ah	F4.0
0Bh	F3.3
0Ch	F2.8
0Dh	F2.4
0Eh	F2.0
0Fh	F1.9
10h	F1.8
11h	F1.6
12h	open

### 13.38 AE Target Value Assignment

Function	To assign target value of AE brightness.	
Command	00A5h	
Parameter	Length	3 byte, including fixed value (3Bh).
	Range	10h~FFh
Status	None	
Reference	<ul style="list-style-type: none"> <li>•To receive command at the moment of exposure mode auto.</li> <li>•To brighten subject by increasing and darken subject by decreasing.</li> <li>•An equivalent backlight correction of 1 aperture is obtained at 73h, 1.5 aperture at 90h, and 2 aperture at C0h.</li> <li>•Default value is 48h.</li> <li>•To return notification at the moment of setting command termination notification ON, when operation terminates. Not to return notification of <b>AE Target Value Assignment</b> command when <b>Backlight Compensation OFF</b> and <b>Backlight Compensation ON</b> commands are executed during operation. To return only notification of last assigned value command in case of resetting another value during operation.</li> </ul>	

● Format of Control Code

d0	d1	d2	d3	d4	d5	d6	d7	d8
Header	Device Num		Command		Parameter		End mark	
FFh	30h	3Xh	00h	A5h	3Bh	p1	p2	EFh



AE target value indicates in hexadecimal 2 figures and parameter value is its ASCII code.					
Example:	70	⇒	46h ⇒	p1	p2
				34h	36h

● Answer Format

d0	d1	d2	d3	d4	d5
Header	Device Num		Error Code		End mark
FEh	30h	3Xh	e0	e1	EFh



Error Flag indicates in 2 figures hexadecimal and returns ASCII code value.			
Example:			e0 e1
■ In case of No Error :	00000000B	⇒	00h ⇒ 30h 30h
■ In case of Busy :	00010000B	⇒	10h ⇒ 31h 30h
■ In case of Parameter Error :	01010000B	⇒	50h ⇒ 35h 30h
■ In case of Mode Error :	10010000B	⇒	90h ⇒ 39h 30h

● Condition of Error flag to be set

Busy	<ul style="list-style-type: none"> <li>•In process of camera initializing operation by <b>Camera Reset</b> command, etc.</li> <li>•In status of exposure mode manual.</li> <li>•In status of AE Lock ON.</li> <li>•In case of executing <b>Preset Move</b> command.</li> </ul>
Parameter Error	In case of assigned parameter out of range.
Mode Error	<ul style="list-style-type: none"> <li>•Not in status of <b>Camera ON</b>.</li> <li>•Not in status of <b>Host Control Mode</b>.</li> </ul>

### 13.39 AE Target Value Request

Camera Control Command Type 1

Function	To return target value of present AE brightness.	
Command	00A5h	
Parameter	Length	1 byte
	Value	"3Ch" (Fixed value)
Status	Length	2 byte
	Range	10h~FFh
Reference	•Default value is 48h.	

● Format of Control Code

	d0	d1	d2	d3	d4	d5	d6
Header	Device Num		Command		Parameter	End mark	
FFh	30h	3Xh	00h	A5h	3Ch	EFh	

● Answer Format

■ In case of No Error

	d0	d1	d2	d3	d4	d5	d6	d7
Header	Device Num		Error Code		AE Target Value		End mark	
FEh	30h	3Xh	30h	30h	s0	s1	EFh	

↓

AE target value indicates in hexadecimal 2 figures and its ASCII code is Status value.
Example: <div style="display: flex; justify-content: space-around; align-items: center;"> <span>70</span> <span>⇒</span> <span>46h</span> <span>⇒</span> <span>s0</span> <span>s1</span> </div> <div style="display: flex; justify-content: space-around; align-items: center;"> <span>34h</span> <span>36h</span> </div>

■ In case of Error

	d0	d1	d2	d3	d4	d5
Header	Device Num		Error Code		End mark	
FEh	30h	3Xh	e0	e1	EFh	

↓

Error Flag indicates in 2 figures hexadecimal and returns ASCII code value.
Example: <div style="display: flex; justify-content: space-around; align-items: center;"> <span>00010000B</span> <span>⇒</span> <span>10h</span> <span>⇒</span> <span>e0</span> <span>e1</span> </div> <div style="display: flex; justify-content: space-around; align-items: center;"> <span>31h</span> <span>30h</span> </div> <div style="display: flex; justify-content: space-around; align-items: center;"> <span>10010000B</span> <span>⇒</span> <span>90h</span> <span>⇒</span> <span>39h</span> <span>30h</span> </div>

● Condition of Error flag to be set

Busy	<ul style="list-style-type: none"> <li>•In process of camera initializing operation by <b>Camera Reset</b> command, etc.</li> <li>•In case of executing <b>Preset Move</b> command.</li> </ul>
Mode Error	<ul style="list-style-type: none"> <li>•Not in status of <b>Camera ON</b>.</li> <li>•Not in status of <b>Host Control Mode</b>.</li> </ul>

### 13.40 Auto White Balance Normal

Camera Control Command Type 1

Function	To set auto white balance.	
Command	00A7h	
Parameter	Length	1 byte
	Value	0h
Status	None	
Reference	<ul style="list-style-type: none"> <li>•To adjust white balance automatically.</li> <li>•To set in default value at the moment of <b>Camera Reset</b> command, <b>Camera ON</b> command and power ON.</li> </ul>	

#### ● Format of Control Code

d0	d1	d2	d3	d4	d5	d6
Header	Device Num		Command		Parameter	End mark
FFh	30h	3Xh	00h	A7h	30h	EFh

#### ● Answer Format

d0	d1	d2	d3	d4	d5
Header	Device Num		Error Code		End mark
FEh	30h	3Xh	e0	e1	EFh



Error Flag indicates in 2 figures hexadecimal and returns ASCII code value.		
Example:		e0 e1
■ In case of No Error :	00000000B ⇒ 00h ⇒	30h 30h
■ In case of Busy :	00010000B ⇒ 10h ⇒	31h 30h
■ In case of Mode Error :	10010000B ⇒ 90h ⇒	39h 30h

#### ● Condition of Error flag to be set

Busy	<ul style="list-style-type: none"> <li>•In process of camera initializing operation by <b>Camera Reset</b> command, etc.</li> <li>•In case of executing <b>Preset Move</b> command.</li> </ul>
Mode Error	<ul style="list-style-type: none"> <li>•Not in status of <b>Camera ON</b>.</li> <li>•Not in status of <b>Host Control Mode</b>.</li> <li>•In the case of not inserted Ir cut-off filter.</li> <li>•In the case of the low-speed shutter.</li> </ul>

### 13.41 Auto White Balance Lock

Camera Control Command Type 1

Function	To stop auto white balance control and set in lock status.	
Command	00A7h	
Parameter	Length	1 byte
	Value	1h
Status	None	
Reference	•Possible to move only to normal mode from this mode.	

● Format of Control Code

d0	d1	d2	d3	d4	d5	d6
Header	Device Num		Command		Parameter	End mark
FFh	30h	3Xh	00h	A7h	31h	EFh

● Answer Format

d0	d1	d2	d3	d4	d5
Header	Device Num		Error Code		End mark
FEh	30h	3Xh	e0	e1	EFh



Error Flag indicates in 2 figures hexadecimal and returns ASCII code value.		
Example:		e0 e1
■ In case of No Error :	00000000B ⇒ 00h ⇒	30h 30h
■ In case of Busy :	00010000B ⇒ 10h ⇒	31h 30h
■ In case of Mode Error :	10010000B ⇒ 90h ⇒	39h 30h

● Condition of Error flag to be set

Busy	<ul style="list-style-type: none"> <li>•In process of camera initializing operation by <b>Camera Reset</b> command, etc.</li> <li>•In status of <b>White Balance Manual Mode.</b></li> <li>•In case of executing <b>Preset Move</b> command.</li> </ul>
Mode Error	<ul style="list-style-type: none"> <li>•Not in status of <b>Camera ON.</b></li> <li>•Not in status of <b>Host Control Mode.</b></li> <li>•In the case of not inserted Ir cut-off filter.</li> <li>•In the case of the low-speed shutter.</li> </ul>



### 13.42 White Balance Manual Mode

Function	To set white balance manual mode.	
Command	00A7h	
Parameter	Length	1 byte
	Value	2h
Status	None	
Reference	<ul style="list-style-type: none"> <li>•To set white balance by using <b>White Balance Value Assignment</b> command.</li> <li>•Possible to move only to normal mode from this mode.</li> <li>•To return notification at the moment of setting command termination notification ON, when operation terminates. But not return notification in case of not changing to normal mode by executing <b>Auto White Balance Normal</b> command during operation.</li> </ul>	

● Format of Control Code

d0	d1	d2	d3	d4	d5	d6
Header	Device Num		Command		Parameter	End mark
FFh	30h	3Xh	00h	A7h	32h	EFh

● Answer Format

d0	d1	d2	d3	d4	d5
Header	Device Num		Error Code		End mark
FEh	30h	3Xh	e0	e1	EFh



Error Flag indicates in 2 figures hexadecimal and returns ASCII code value.		
Example:		e0 e1
■ In case of No Error :	00000000B ⇒ 00h ⇒	30h 30h
■ In case of Busy :	00010000B ⇒ 10h ⇒	31h 30h
■ In case of Mode Error :	10010000B ⇒ 90h ⇒	39h 30h

● Condition of Error flag to be set

Busy	<ul style="list-style-type: none"> <li>•In process of camera initializing operation by <b>Camera Reset</b> command, etc.</li> <li>•In status of <b>Auto White Balance in Lock</b>.</li> <li>•In case of executing <b>Preset Move</b> command.</li> </ul>
Mode Error	<ul style="list-style-type: none"> <li>•Not in status of <b>Camera ON</b>.</li> <li>•Not in status of <b>Host Control Mode</b>.</li> <li>•In the case of not inserted Ir cut-off filter.</li> <li>•In the case of the low-speed shutter.</li> </ul>

In status of changeable white balance mode

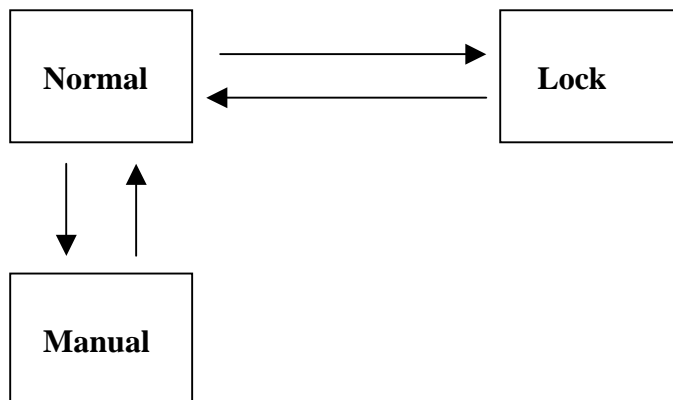

### 13.43 White Balance Value Assignment

Camera Control Command Type 1

Function	To set manual value of white balance.	
Command	00A7h	
Parameter	Length	3 byte including fixed value (34h).
	Range	00h (enhanced Red) ~ FFh (enhanced Blue)
Status	None	
Reference	•To receive command at white balance manual mode.	

● Format of Control Code

d0	d1	d2	d3	d4	d5	d6	d7	d8
Header	Device Num		Command		Parameter			End mark
FFh	30h	3Xh	00h	A7h	34h	p1	p2	EFh



Manual value indicates in hexadecimal 2 figures and parameter value is its ASCII code.	
Example:	128 ⇒ 80h ⇒ p1 38h p2 30h

● Answer Format

d0	d1	d2	d3	d4	d5
Header	Device Num		Error Code		End mark
FEh	30h	3Xh	e0	e1	EFh



Error Flag indicates in 2 figures hexadecimal and returns ASCII code value.	
Example:	e0 e1
■ In case of No Error :	00000000B ⇒ 00h ⇒ 30h 30h
■ In case of Busy :	00010000B ⇒ 10h ⇒ 31h 30h
■ In case of Parameter Error :	01010000B ⇒ 50h ⇒ 35h 30h
■ In case of Mode Error :	10010000B ⇒ 90h ⇒ 39h 30h

● Condition of Error flag to be set

Busy	<ul style="list-style-type: none"> <li>•In process of camera initializing operation by <b>Camera Reset</b> command, etc.</li> <li>•Except white balance manual mode.</li> <li>•In case of executing <b>Preset Move</b> command.</li> </ul>
Parameter Error	•In case of assigned parameter out of range.
Mode Error	<ul style="list-style-type: none"> <li>•Not in status of <b>Camera ON</b>.</li> <li>•Not in status of <b>Host Control Mode</b>.</li> <li>•In the case of not inserted Ir cut-off filter.</li> </ul>

### 13.44 White Balance Value Request

Camera Control Command Type 1

Function	To return value of present white balance.	
Command	00A7h	
Parameter	Length	1 byte
	Value	5h
Status	Length	2 byte
	Range	00h (enhanced Red) ~ FFh (enhanced Blue)
Reference	•To return 80h at the moment of executing command except white balance manual mode.	

#### ● Format of Control Code

	d0	d1	d2	d3	d4	d5	d6
Header	Device Num		Command		Parameter	End mark	
FFh	30h	3Xh	00h	A7h	35h	EFh	

#### ● Answer Format

##### ■ In case of No Error

	d0	d1	d2	d3	d4	d5	d6	d7
Header	Device Num		Error Code		Manual Value		End mark	
FEh	30h	3Xh	30h	30h	s0	s1	EFh	

↓

Manual value indicates in hexadecimal 2 figures and its ASCII code is Status value.	
Example:	
128 ⇒ 80h ⇒	s0 s1 38h 30h

##### ■ In case of Error

	d0	d1	d2	d3	d4	d5
Header	Device Num		Error Code		End mark	
FEh	30h	3Xh	e0	e1	EFh	

↓

Error Flag indicates in 2 figures hexadecimal and returns ASCII code value.	
Example:	
■ In case of Busy :	00010000B ⇒ 10h ⇒ 31h 30h
■ In case of Mode Error :	10010000B ⇒ 90h ⇒ 39h 30h

#### ● Condition of Error flag to be set

Busy	<ul style="list-style-type: none"> <li>•In process of camera initializing operation by <b>Camera Reset</b> command, etc.</li> <li>•In case of executing <b>Preset Move</b> command.</li> </ul>
Mode Error	<ul style="list-style-type: none"> <li>•Not in status of <b>Camera ON</b>.</li> <li>•Not in status of <b>Host Control Mode</b>.</li> <li>•In the case of not inserted Ir cut-off filter.</li> </ul>

### 13.45 Fade Normal

### Camera Control Command Type 2

Function	To return to normal output of image and release fade status slowly.	
Command	00A9h	
Parameter	Length	1 byte
	Value	0h
Status	None	
Reference	<ul style="list-style-type: none"> <li>•To fade in from white in case of white fade status, and from black in case of black fade in.</li> <li>•To change operation by receiving command, even though executing another fade related command.</li> <li>•To be set in default value at the moment of executing <b>Camera Reset</b> and <b>Camera ON</b> during power ON.</li> <li>•To return notification at the moment of setting command termination notification ON, when operation terminates. But return only notification of last executed command, in case of executing another fade command during operation.</li> </ul>	

#### ● Format of Control Code

d0	d1	d2	d3	d4	d5	d6
Header	Device Num		Command		Parameter	End mark
FFh	30h	3Xh	00h	A9h	30h	EFh

#### ● Answer Format

d0	d1	d2	d3	d4	d5
Header	Device Num		Error Code		End mark
FEh	30h	3Xh	e0	e1	EFh



Error Flag indicates in 2 figures hexadecimal and returns ASCII code value.		
Example:		e0 e1
■ In case of No Error :	0000000B ⇒ 00h	⇒ 30h 30h
■ In case of Busy :	00010000B ⇒ 10h	⇒ 31h 30h
■ In case of Mode Error :	10010000B ⇒ 90h	⇒ 39h 30h

#### ● Condition of Error flag to be set

Busy	<ul style="list-style-type: none"> <li>•In process of camera initializing operation by <b>Camera Reset</b> command, etc.</li> <li>•In case of executing <b>Preset Move</b> command.</li> </ul>
Mode Error	<ul style="list-style-type: none"> <li>•Not in status of <b>Camera ON</b>.</li> <li>•Not in status of <b>Host Control Mode</b>.</li> </ul>

### 13.46 Fade White

Function	To fade in white slowly.	
Command	00A9h	
Parameter	Length	1 byte
	Value	1h
Status	None	
Reference	<ul style="list-style-type: none"> <li>•To change operation by receiving command, even though executing another fade related command.</li> <li>•To return Notification at the moment of setting command termination notification ON, when operation terminates. But return only notification of last executed command, in case of executing another fade command during operation.</li> </ul>	

● Format of Control Code

d0	d1	d2	d3	d4	d5	d6
Header	Device Num		Command		Parameter	End mark
FFh	30h	3Xh	00h	A9h	31h	EFh

● Answer Format

d0	d1	d2	d3	d4	d5
Header	Device Num		Error Code		End mark
FEh	30h	3Xh	e0	e1	EFh



Error Flag indicates in 2 figures hexadecimal and returns ASCII code value.		
Example:		e0 e1
■ In case of No Error :	00000000B ⇒ 00h ⇒	30h 30h
■ In case of Busy :	00010000B ⇒ 10h ⇒	31h 30h
■ In case of Mode Error :	10010000B ⇒ 90h ⇒	39h 30h

● Condition of Error flag to be set

Busy	<ul style="list-style-type: none"> <li>•In process of camera initializing operation by <b>Camera Reset</b> command, etc.</li> <li>•In case of executing <b>Preset Move</b> command.</li> </ul>
Mode Error	<ul style="list-style-type: none"> <li>•Not in status of <b>Camera ON</b>.</li> <li>•Not in status of <b>Host Control Mode</b>.</li> </ul>

### 13.47 Fade Hi Speed White

Function	To fade in white with Hi speed.	
Command	00A9h	
Parameter	Length	1 byte
	Value	2h
Status	None	
Reference	<ul style="list-style-type: none"> <li>•To change operation by receiving command, even though executing another fade related command.</li> <li>•To return notification at the moment of setting command termination notification ON, when operation terminates. But return only notification of last executed command, in case of executing another fade command during operation.</li> </ul>	

● Format of Control Code

d0	d1	d2	d3	d4	d5	d6
Header	Device Num		Command		Parameter	End mark
FFh	30h	3Xh	00h	A9h	32h	EFh

● Answer Format

d0	d1	d2	d3	d4	d5
Header	Device Num		Error Code		End mark
FEh	30h	3Xh	e0	e1	EFh



Error Flag indicates in 2 figures hexadecimal and returns ASCII code value.		
Example:		e0 e1
■ In case of No Error :	00000000B ⇒ 00h ⇒	30h 30h
■ In case of Busy :	00010000B ⇒ 10h ⇒	31h 30h
■ In case of Mode Error :	10010000B ⇒ 90h ⇒	39h 30h

● Condition of Error flag to be set

Busy	<ul style="list-style-type: none"> <li>•In process of camera initializing operation by <b>Camera Reset</b> command, etc.</li> <li>•In case of executing <b>Preset Move</b> command.</li> </ul>
Mode Error	<ul style="list-style-type: none"> <li>•Not in status of <b>Camera ON</b>.</li> <li>•Not in status of <b>Host Control Mode</b>.</li> </ul>

### 13.48 Fade Hi Speed Black

Function	To fade in black with Hi speed.	
Command	00A9h	
Parameter	Length	1 byte
	Value	3h
Status	None	
Reference	<ul style="list-style-type: none"> <li>•To change operation by receiving command, even though executing another fade related command.</li> <li>•To return notification at the moment of setting command termination notification ON, when operation terminates. But return only notification of last executed command, in case of executing another fade command during operation.</li> </ul>	

● Format of Control Code

d0	d1	d2	d3	d4	d5	d6
Header	Device Num		Command		Parameter	End mark
FFh	30h	3Xh	00h	A9h	33h	EFh

● Answer Format

d0	d1	d2	d3	d4	d5
Header	Device Num		Error Code		End mark
FEh	30h	3Xh	e0	e1	EFh



Error Flag indicates in 2 figures hexadecimal and returns ASCII code value.		
Example:		e0 e1
■ In case of No Error :	00000000B ⇒ 00h ⇒	30h 30h
■ In case of Busy :	00010000B ⇒ 10h ⇒	31h 30h
■ In case of Mode Error :	10010000B ⇒ 90h ⇒	39h 30h

● Condition of Error flag to be set

Busy	<ul style="list-style-type: none"> <li>•In process of camera initializing operation by <b>Camera Reset</b> command, etc.</li> <li>•In case of executing <b>Preset Move</b> command.</li> </ul>
Mode Error	<ul style="list-style-type: none"> <li>•Not in status of <b>Camera ON</b>.</li> <li>•Not in status of <b>Host Control Mode</b>.</li> </ul>

### 13.49 Camera Reset

### Camera Control Command Type 2

Function	To camera reset operation
Command	00AAh
Parameter	None
Status	None
Reference	<ul style="list-style-type: none"> <li>•To stop executing another operation of camera (except <b>preset move</b>) and to force to set in initialized status regardless of pedestal initialize.</li> <li>•Not to accept camera command during executing <b>Camera Reset</b>.</li> <li>•To set in status of <b>Focus Automatic, Zoom Stop, Auto White Balance Normal, Fade Normal, Shutter Speed Program, Backlight Compensation OFF, Exposure Auto, IR Filter ON and IR LED Light OFF</b>.</li> <li>•To return notification at the moment of setting command termination notification ON, when command normal finishes.</li> </ul>

#### ● Format of Control Code

d0	d1	d2	d3	d4	d5
Header	Device Num		Command		End mark
FFh	30h	3Xh	00h	AAh	EFh

#### ● Answer Format

d0	d1	d2	d3	d4	d5
Header	Device Num		Error Code		End mark
FEh	30h	3Xh	e0	e1	EFh



Error Flag indicates in 2 figures hexadecimal and returns ASCII code value.		
Example:		e0 e1
■ In case of No Error :	00000000B ⇒ 00h ⇒	30h 30h
■ In case of Busy :	00010000B ⇒ 10h ⇒	31h 30h
■ In case of Mode Error :	10010000B ⇒ 90h ⇒	39h 30h

#### ● Condition of Error flag to be set

Busy	<ul style="list-style-type: none"> <li>•In process of camera initializing operation by <b>Camera Reset</b> command, etc.</li> <li>•In case of executing <b>Preset Move</b> command.</li> </ul>
Mode Error	<ul style="list-style-type: none"> <li>•Not in status of <b>Camera ON</b>.</li> <li>•Not in status of <b>Host Control Mode</b>.</li> </ul>



### 13.50 Zoom Ratio Request

Camera Control Command Type 1

Function	To return zoom ratio.	
Command	00ABh	
Parameter	None	
Status	Length	2 byte
	Value	1Ah (Fixed)
Reference	•To come out 1Ah and return it equal to zoom ratio 26 times.	

● Format of Control Code

	d0	d1	d2	d3	d4	d5
Header	Device Num		Command		End mark	
	FFh	30h	3Xh	00h	ABh	EFh

● Answer Format

■ In case of No Error

	d0	d1	d2	d3	d4	d5	d6	d7
Header	Device Num		Error Code		Zoom ratio		End mark	
	FEh	30h	3Xh	30h	30h	s0h	s1h	EFh

↓

Zoom ratio indicates in hexadecimal 2 figures and its ASCII code is Status value.	
Example:	16 ⇒ 10h ⇒ s0 s1 31h 30h

■ In case of Error

	d0	d1	d2	d3	d4	d5
Header	Device Num		Error Code		End mark	
	FEh	30h	3Xh	e0	e1	EFh

↓

Error Flag indicates in 2 figures hexadecimal and returns ASCII code value.	
Example:	e0 e1
■ In case of Busy :	00010000B ⇒ 10h ⇒ 31h 30h
■ In case of Mode Error :	10010000B ⇒ 90h ⇒ 39h 30h

● Condition of Error flag to be set

Busy	<ul style="list-style-type: none"> <li>•In process of camera initializing operation by <b>Camera Reset</b> command, etc.</li> <li>•In case of executing <b>Preset Move</b> command.</li> </ul>
Mode Error	<ul style="list-style-type: none"> <li>•Not in status of <b>Camera ON</b>.</li> <li>•Not in status of <b>Host Control Mode</b>.</li> </ul>

### 13.51 Pixel Size Request

Function	To return pixel size of CCD	
Command	00ACh	
Parameter	None	
Status	Length	2 byte
	Value	14h (fixed)
Reference	<ul style="list-style-type: none"> <li>To come out and return 14h because of using 1/4 inch CCD.</li> <li>1/4 Numerator: first byte, Denominator: second byte.</li> </ul>	

● Format of Control Code

d0	d1	d2	d3	d4	d5
Header	Device Num		Command		End mark
FFh	30h	3Xh	00h	ACh	EFh

● Answer Format

■ In case of No Error

d0	d1	d2	d3	d4	d5	d6	d7
Header	Device Num		Error Code		pixel size ratio		End mark
FEh	30h	3Xh	30h	30h	s0h	s1h	EFh

↓

Pixel size ratio indicates in hexadecimal 2 figures and its ASCII code is Status value.	
Example:	$1/4 \Rightarrow 14h \Rightarrow \begin{matrix} s0 & s1 \\ 31h & 34h \end{matrix}$

■ In case of Error

d0	d1	d2	d3	d4	d5
Header	Device Num		Error Code		End mark
FEh	30h	3Xh	e0	e1	EFh

↓

Error Flag indicates in 2 figures hexadecimal and returns ASCII code value.	
Example:	$\begin{matrix} \blacksquare \text{ In case of Busy :} & 00010000B & \Rightarrow & 10h & \Rightarrow & \begin{matrix} e0 & e1 \\ 31h & 30h \end{matrix} \\ \blacksquare \text{ In case of Mode Error :} & 10010000B & \Rightarrow & 90h & \Rightarrow & \begin{matrix} e0 & e1 \\ 39h & 30h \end{matrix} \end{matrix}$

● Condition of Error flag to be set

Busy	<ul style="list-style-type: none"> <li>In process of camera initializing operation by <b>Camera Reset</b> command, etc.</li> <li>In case of executing <b>Preset Move</b> command.</li> </ul>
Mode Error	<ul style="list-style-type: none"> <li>Not in status of <b>Camera ON</b>.</li> <li>Not in status of <b>Host Control Mode</b>.</li> </ul>

### 13.52 Setting Insertion of Infrared Cut Filter

Camera Control Command Type 2

Function	Sets the status when infrared cut filter is inserted.	
Command	00B5h	
Parameter	Parameter length	1 byte.
	Parameter value	1h
Status	None	
Reference	•Once this command is received, the filter insertion process and the built-in infrared light LED OFF process are both performed simultaneously.	

● Format of Control Code

d0	d1	d2	d3	d4	d5	d6
Header	Device Num		Command		Parameter	End mark
FFh	30h	3Xh	00h	B5h	31h	EFh

● Answer Format

d0	d1	d2	d3	d4	d5
Header	Device Num		Error Code		End mark
FEh	30h	3Xh	e0	e1	EFh



Error Flag indicates in 2 figures hexadecimal and returns ASCII code value.		
Example:		e0 e1
■ No Error :	0000000B ⇒	00h ⇒ 30h 30h
■ Busy :	00010000B ⇒	10h ⇒ 31h 30h
■ Parameter Error :	01010000B ⇒	50h ⇒ 35h 30h
■ Mode Error :	10010000B ⇒	90h ⇒ 39h 30h

● Conditions for setting of error flag

Busy	•Filter insertion/removal operation is in progress.
Parameter Error	•The designated parameter is an invalid value.
Mode Error	•Not in status of <b>Camera ON</b> . •Not in status of <b>Host Control Mode</b> . •This command was received while <b>filter was inserted</b> .

### 13.53 Settings when Infrared Cut Filter Not Inserted Camera Control Command Type 2

Function	Sets the status when infrared cut filter is not inserted.	
Command	00B5h	
Parameter	Length	1 byte.
	Value	0h
Status	None	
Reference		

● Format of Control Code

d0	d1	d2	d3	d4	d5	d6
Header	Device Num		Command		Parameter	End mark
FFh	30h	3Xh	00h	B5h	30h	EFh

● Answer Format

d0	d1	d2	d3	d4	d5
Header	Device Num		Error Code		End mark
FEh	30h	3Xh	e0	e1	EFh

↓

Error Flag indicates in 2 figures hexadecimal and returns ASCII code value.					
Example:					e0 e1
■ In case of No Error :	00000000B	⇒	00h	⇒	30h 30h
■ In case of Busy :	00010000B	⇒	10h	⇒	31h 30h
■ In case of Parameter Error :	01010000B	⇒	50h	⇒	35h 30h
■ In case of Mode Error :	10010000B	⇒	90h	⇒	39h 30h

● Condition of Error flag to be set

Busy	•Filter insertion/removal operation is in progress
Parameter Error	•In case of assigned parameter illegal
Mode Error	•Not in status of <b>Camera ON.</b> •Not in status of <b>Host Control Mode.</b> •This command was received while <b>filter was inserted.</b>

### 13.54 Infrared Cut Filter Status Request

Camera Control Command Type 1

Function	Returns the setting status of the infrared cut filter.	
Command	00B6h	
Parameter	None	
Status	Length	1 byte
	Value	Filter inserted status : 1h
		Filter not inserted status : 0h
	Under the Filter movement : 2h	
Reference	•Infrared cut filter status is returned as a one-digit hexadecimal number.	

● Format of Control Code

d0	d1	d2	d3	d4	d5
Header	Device Num		Command		End mark
FFh	30h	3Xh	00h	B6h	EFh

● Answer Format

■ No Error

d0	d1	d2	d3	d4	d5	d6
Header	Device Num		Error Code		Status	End mark
FEh	30h	3Xh	30h	30h	s0	EFh



The setting value is expressed as a one-digit hexadecimal number with the ASCII code as a status value.	
Inserted status:	1h ⇒ 31h
Not inserted status:	0h ⇒ 30h

■ Generated Error

d0	d1	d2	d3	d4	d5
Header	Device Num		Error Code		End mark
FEh	30h	3Xh	e0	e1	EFh



Error Flag indicates in 2 figures hexadecimal and returns ASCII code value	
Example:	e0 e1
■ In case of Mode Error :	10010000B ⇒ 90h ⇒ 39h 30h

● Condition of Error flag to be set

Mode Error	<ul style="list-style-type: none"> <li>•Not in status of <b>Camera ON</b></li> <li>•Not in status of <b>Host Control Mode</b></li> </ul>
------------	--

## 13.55 Electronic Zoom Setting

## Camera Control Command Type 2

Function	Sets the electronic zoom to the designated magnification.	
Command	00B7h	
Parameter	Length	2 byte
	Value	The electronic zoom magnification is designated by 2 bytes.
Status	None	
Reference	<ul style="list-style-type: none"> <li>•Available magnification setting values                      00h: 1x (no electronic zoom)                      01h: 1x (no electronic zoom)                      02h: 2x                      04h: 4x                      08h: 8x                      0Ch: 12x</li> <li>•The electronic zoom and noise reduction, and the electronic zoom and slow shutter cannot be set at the same time. A mode error will occur.</li> </ul>	

### ● Format of Control Code

d0	d1	d2	d3	d4	d5	d6	d7
Header	Device Num		Command		Parameter		End mark
FFh	30h	3Xh	00h	B7h	p0	p1	EFh

↓

The magnification is expressed as a two-digit hexadecimal number with the ASCII code as a status value.
Example: Setting value: 16x ⇒ 10h ⇒ p0 p1 31h 30h

### ● Answer Format

d0	d1	d2	d3	d4	d5
Header	Device Num		Error Code		End mark
FEh	30h	3Xh	e0	e1	EFh

↓

Error Flag indicates in 2 figures hexadecimal and returns ASCII code value
Example: <ul style="list-style-type: none"> <li>■ In case of No Error : 0000000B ⇒ 00h ⇒ e0 e1 30h 30h</li> <li>■ In case of Parameter Error : 0101000B ⇒ 50h ⇒ 35h 30h</li> <li>■ In case of Mode Error : 1001000B ⇒ 90h ⇒ 39h 30h</li> </ul>

### ● Conditions for setting of error flag

Parameter Error	•In case of assigned parameter illegal
Mode Error	<ul style="list-style-type: none"> <li>•Not in status of <b>Camera ON</b></li> <li>•Not in status of <b>Host Control Mode</b></li> <li>•<b>Slow Shutter</b> has been selected.</li> </ul>

### 13.56 Electronic Zoom Setting Verification

Function	Returns the electronic zoom magnification that was set.	
Command	00B8h	
Parameter	None	
Status	Length	2 byte
	Value	Electronic zoom magnification.
Reference	<ul style="list-style-type: none"> <li>•Electronic zoom magnification setting values            00h: 1x (no electronic zoom)            01h: 1x (no electronic zoom)            02h: 2x            04h: 4x            08h: 8x            0Ch: 12x</li> <li>•The electronic zoom magnification is returned as a two-digit hexadecimal number.</li> </ul>	

● Format of Control Code

d0	d1	d2	d3	d4	d5
Header	Device Num		Command		End mark
FFh	30h	3Xh	00h	B8h	EFh

● Answer Format

■ No Error

d0	d1	d2	d3	d4	d5	d6	d7
Header	Device Num		Error Code		Status		End mark
FEh	30h	3Xh	30h	30h	s0	s1	EFh

↓

The magnification is expressed as a two-digit hexadecimal number with the ASCII code as a status value.	
Example:	s0 s1
Setting value: 2x ⇒ 02h ⇒	30h 32h
Setting value: 16x ⇒ 10h ⇒	31h 30h

■ Generated Error

d0	d1	d2	d3	d4	d5
Header	Device Num		Error Code		End mark
FEh	30h	3Xh	e0	e1	EFh

↓

Error Flag indicates in 2 figures hexadecimal and returns ASCII code value	
Example:	e0 e1
■ In case of Mode Error :	10010000B ⇒ 90h ⇒ 39h 30h

● Conditions for setting of error flag

Mode Error	<ul style="list-style-type: none"> <li>•Not in status of <b>Camera ON</b></li> <li>•Not in status of <b>Host Control Mode</b></li> </ul>
------------	--

### 13.57 Noise Reduction OFF

Camera Control Command Type 2

Function	Sets the noise reduction to OFF.	
Command	00B9h	
Parameter	Length	1 byte
	Value	0h
Status	None	
Reference		

● Format of Control Code

d0	d1	d2	d3	d4	d5	d6
Header	Device Num		Command		Parameter	End mark
FFh	30h	3Xh	00h	B9h	30h	EFh

● Answer Format

d0	d1	d2	d3	d4	d5
Header	Device Num		Error Code		End mark
FEh	30h	3Xh	e0	e1	EFh



Error Flag indicates in 2 figures hexadecimal and returns ASCII code value					
Example:					
■ In case of No Error :	00000000B	⇒	00h	⇒	e0 e1 30h 30h
■ In case of Parameter Error :	01010000B	⇒	50h	⇒	35h 30h
■ In case of Mode Error :	10010000B	⇒	90h	⇒	39h 30h

● Conditions for setting of error flag

Parameter Error	•In case of assigned parameter illegal
Mode Error	•Not in status of <b>Camera ON</b> •Not in status of <b>Host Control Mode</b> • <b>Slow Shutter</b> has been selected.



### 13.58 Noise Reduction Low Level ON

Camera Control Command Type 2

Function	Sets the noise reduction to low level ON.	
Command	00B9h	
Parameter	Length	1 byte
	Value	1h
Status	None	
Reference		

● Format of Control Code

d0	d1	d2	d3	d4	d5	d6
Header	Device Num		Command		Parameter	End mark
FFh	30h	3Xh	00h	B9h	31h	EFh

● Answer Format

d0	d1	d2	d3	d4	d5
Header	Device Num		Command		End mark
FEh	30h	3Xh	e0	e1	EFh

↓

Error Flag indicates in 2 figures hexadecimal and returns ASCII code value		
Example:		e0 e1
■ In case of No Error :	00000000B ⇒ 00h ⇒	30h 30h
■ In case of Parameter Error :	01010000B ⇒ 50h ⇒	35h 30h
■ In case of Mode Error :	10010000B ⇒ 90h ⇒	39h 30h

● Conditions for setting of error flag

Parameter Error	•In case of assigned parameter illegal
Mode Error	•Not in status of <b>Camera ON</b> •Not in status of <b>Host Control Mode</b> •Camera is set to <b>Slow Shutter</b>

### 13.59 Noise Reduction High Level ON

Camera Control Command Type 2

Function	Sets the noise reduction to high level ON.	
Command	00B9h	
Parameter	Length	1 byte
	Value	2h
Status	None	
Reference		

● Format of Control Code

d0	d1	d2	d3	d4	d5	d6
Header	Device Num		Command		Parameter	End mark
FFh	30h	3Xh	00h	B9h	32h	EFh

● Answer Format

d0	d1	d2	d3	d4	d5
Header	Device Num		Command		End mark
FEh	30h	3Xh	e0	e1	EFh



Error Flag indicates in 2 figures hexadecimal and returns ASCII code value					
Example:					
■ In case of No Error :	00000000B	⇒	00h	⇒	e0 e1
■ In case of Parameter Error :	01010000B	⇒	50h	⇒	35h 30h
■ In case of Mode Error :	10010000B	⇒	90h	⇒	39h 30h

● Conditions for setting of error flag

Parameter Error	•In case of assigned parameter illegal
Mode Error	•Not in status of <b>Camera ON</b> •Not in status of <b>Host Control Mode</b> •Camera is set to <b>Slow Shutter</b>

### 13.60 Noise Reduction Setting Verification

Camera Control Command Type 1

Function	Returns the noise reduction setting value.	
Command	00BAh	
Parameter	None	
Status	Length	1 byte
	Range	0h~2h
Reference	<ul style="list-style-type: none"> <li>•Noise reduction setting value</li> <li>0h: Noise reduction OFF</li> <li>1h: Low level noise reduction ON</li> <li>2h: High level noise reduction ON</li> </ul>	

● Format of Control Code

d0	d1	d2	d3	d4	d5
Header	Device Num		Command		End mark
FFh	30h	3Xh	00h	BAh	EFh

● Answer Format

■ No Error

d0	d1	d2	d3	d4	d5	d6
Header	Device Num		Error Code		Status	End mark
FEh	30h	3Xh	30h	30h	s0	EFh



The magnification is expressed as a one-digit hexadecimal number with the ASCII code as a status value.	
Noise reduction	s0
Off :	0h ⇒ 30h
Low level on :	1h ⇒ 31h
High level on :	2h ⇒ 32h

■ Generated Error

d0	d1	d2	d3	d4	d5
Header	Device Num		Error Code		End mark
FEh	30h	3Xh	e0	e1	EFh



Error Flag indicates in 2 figures hexadecimal and returns ASCII code value	
Example:	e0 e1
■ In case of Mode Error :	10010000B ⇒ 90h ⇒ 39h 30h

● Conditions for setting of error flag

Mode Error	<ul style="list-style-type: none"> <li>•Not in status of <b>Camera ON</b></li> <li>•Not in status of <b>Host Control Mode</b></li> </ul>
------------	--

### 13.61 Dome Mode Setting

Function	Sets the dome mode to the designated value.												
Command	00BDh												
Parameter	Length	4 byte											
	Range	0000h~0003h (Dome mode designation)											
Status	None												
Reference	<ul style="list-style-type: none"> <li>•Dome mode setting value               <ul style="list-style-type: none"> <li>00h: Select cam path 0 to 9</li> <li>01h: Select cam path 0 to 8</li> <li>02h: Select cam path 0 to 7</li> <li>03h: Select cam path 0 to 6</li> </ul> </li> <li>•Setting value of cam path 0 to 9               <table style="margin-left: 20px; border: none;"> <tr> <td>0: INF</td> <td>1: 830cm</td> <td>2: 380cm</td> <td>3: 240cm</td> <td>4: 230cm</td> </tr> <tr> <td>5: 155cm</td> <td>6: 86cm</td> <td>7: 27.2cm</td> <td>8 :7.3cm</td> <td>9 :0.7cm</td> </tr> </table> </li> </ul>			0: INF	1: 830cm	2: 380cm	3: 240cm	4: 230cm	5: 155cm	6: 86cm	7: 27.2cm	8 :7.3cm	9 :0.7cm
0: INF	1: 830cm	2: 380cm	3: 240cm	4: 230cm									
5: 155cm	6: 86cm	7: 27.2cm	8 :7.3cm	9 :0.7cm									

● Format of Control Code

d0	d1	d2	d3	d4	d5	d6	d7	d8	d9
Header	Device Num		Command		Parameter			End mark	
FFh	30h	3Xh	00h	BDh	30h	30h	p0	p1	EFh



The Dome setting value is expressed as a two-digit hexadecimal number with the ASCII code as the status value.

Example:

Doom mode :	01h	⇒	p0 p1
			30h 31h
Doom mode :	03h	⇒	30h 33h

● Answer Format

d0	d1	d2	d3	d4	d5
Header	Device Num		Error Code		End mark
FEh	30h	3Xh	e0	e1	EFh



Error Flag indicates in 2 figures hexadecimal and returns ASCII code value

Example:

			e0	e1
■ In case of No Error :	00000000B	⇒	00h	⇒ 30h 30h
■ In case of Parameter Error :	01010000B	⇒	50h	⇒ 35h 30h
■ In case of Mode Error :	10010000B	⇒	90h	⇒ 39h 30h

● Conditions for setting of error flag

Parameter Error	•In case of assigned parameter illegal
Mode Error	•Not in status of <b>Camera ON</b> •Not in status of <b>Host Control Mode</b>

### 13.62 Dome Mode Setting Verification

Function	Returns the dome mode setting value.	
Command	00BDh	
Parameter	Length	2 byte
	Value	01h
Status	Length	2 byte
	Range	00h~03h
Reference	<ul style="list-style-type: none"> <li>•Dome mode setting value               <ul style="list-style-type: none"> <li>00h: Select cam path 0 to 9</li> <li>01h: Select cam path 0 to 8</li> <li>02h: Select cam path 0 to 7</li> <li>03h: Select cam path 0 to 6</li> </ul> </li> <li>•Setting value of cam path 0 to 9               <ul style="list-style-type: none"> <li>0: INF    1: 450cm    2: 201cm    3: 120cm    4: 80cm</li> <li>5: 40.7cm    6: 9.2cm    7: 1cm</li> </ul> </li> </ul>	

● Format of Control Code

d0	d1	d2	d3	d4	d5	d6	d7
Header	Device Num		Command		Parameter		End mark
FFh	30h	3Xh	00h	BDh	30h	31h	EFh

● Answer Format

■ No Error

d0	d1	d2	d3	d4	d5	d6	d7
Header	Device Num		Error Code		Status		End mark
FEh	30h	3Xh	30h	30h	s0	s1	EFh



Setting value indicates in 2 figures hexadecimal and returns ASCII code value							
Noise Reduction				s0 s1			
Doom setting value :	00h	⇒	30h	30h			
Doom setting value :	01h	⇒	30h	31h			
Doom setting value :	02h	⇒	30h	32h			
Doom setting value :	03h	⇒	30h	33h			

■ Generated Error

d0	d1	d2	d3	d4	d5
Header	Device Num		Error Code		End mark
FEh	30h	3Xh	e0	e1	EFh



Error Flag indicates in 2 figures hexadecimal and returns ASCII code value							
Example:				e0 e1			
■ In case of Parameter Error :	01010000B	⇒	50h	⇒	35h	30h	
■ In case of Mode Error :	10010000B	⇒	90h	⇒	39h	30h	

● Conditions for setting of error flag

Parameter Error	•In case of assigned parameter illegal
Mode Error	•Not in status of <b>Camera ON</b> •Not in status of <b>Host Control Mode</b>

### 13.63 Product Version Request

### Camera Control Command Type 1

Function	To return version value of camera section.	
Command	00BEh	
Parameter	Length	1 byte
	Value	0h
Status	Length	2 byte
	Range	00h~FFh
Reference	•To return ROM version value in hexadecimal 2 figures.	

#### ● Format of Control Code

d0	d1	d2	d3	d4	d5	d6
Header	Device Num		Command		Parameter	End mark
FFh	30h	3Xh	00h	BEh	30h	EFh

#### ● Answer Format

##### ■ No Error

d0	d1	d2	d3	d4	d5	d6	d7
Header	Device Num		Error Code		Version Value		End mark
FEh	30h	3Xh	30h	30h	s0	s1	EFh

↓

Version value indicates in hexadecimal 2 figures and its ASCII code is Status value.							
Example:							
	87	⇒	57h	⇒	s0	s1	
					35h	37h	

##### ■ Generated Error

d0	d1	d2	d3	d4	d5
Header	Device Num		Error Code		End mark
FEh	30h	3Xh	e0	e1	EFh

↓

Error Flag indicates in 2 figures hexadecimal and returns ASCII code value.							
Example:							
					e0	e1	
■	In case of Busy :		00010000B	⇒	10h	⇒	31h 30h
■	In case of Mode Error :		10010000B	⇒	90h	⇒	39h 30h

#### ● Conditions for setting of error flag

Busy	<ul style="list-style-type: none"> <li>•In process of camera initializing operation by <b>Camera Reset</b> command, etc.</li> <li>•In case of executing <b>Preset Move</b> command.</li> </ul>
Mode Error	<ul style="list-style-type: none"> <li>•Not in status of <b>Camera ON</b>.</li> <li>•Not in status of <b>Host Control Mode</b>.</li> </ul>

### 13.64 EEPROM Version Request

Camera Control Command Type 1

Function	To return EEPROM version value of camera section.	
Command	00BEh	
Parameter	Length	1 byte
	Value	1h
Status	Length	2 byte
	Range	00h~FFh
Reference	•To return EEPROM version value in hexadecimal 2 figures.	

● Format of Control Code

d0	d1	d2	d3	d4	d5	d6
Header	Device Num		Command		Parameter	End mark
FFh	30h	3Xh	00h	BEh	31h	EFh

● Answer Format

■ No Error

d0	d1	d2	d3	d4	d5	d6	d7
Header	Device Num		Error Code		Version Value		End mark
FEh	30h	3Xh	30h	30h	s0	s1	EFh

↓

Version value indicates in hexadecimal 2 figures and its ASCII code is Status value.							
Example:							
	07	⇒	07h	⇒	s0	s1	
					30h	37h	

■ Generated Error

d0	d1	d2	d3	d4	d5
Header	Device Num		Error Code		End mark
FEh	30h	3Xh	e0	e1	EFh

↓

Error Flag indicates in 2 figures hexadecimal and returns ASCII code value							
Example:							
					e0	e1	
■ In case of Busy :			00010000B	⇒	10h	⇒	31h 30h
■ In case of Mode Error :			10010000B	⇒	90h	⇒	39h 30h

● Conditions for setting of error flag

Busy	<ul style="list-style-type: none"> <li>•In process of camera initializing operation by <b>Camera Reset</b> command, etc.</li> <li>•In case of executing <b>Preset Move</b> command.</li> </ul>
Mode Error	<ul style="list-style-type: none"> <li>•Not in status of <b>Camera ON</b>.</li> <li>•Not in status of <b>Host Control Mode</b>.</li> </ul>

## 14. Details of System Control Commands

### 14.1 Alarm Output OFF

System Control Command Type 1

Function	Sets the alarm output (+/- terminal) to open.	
Command	0072h	
Parameter	Length	1 byte
	Value	0h
Status	None	
Reference		

#### ● Format of Control Code

d0	d1	d2	d3	d4	d5	d6
Header	Device Num		Command		Parameter	End mark
FFh	30h	3Xh	00h	72h	30h	EFh

#### ● Answer Format

d0	d1	d2	d3	d4	d5
Header	Device Num		Error Code		End mark
FEh	30h	3Xh	e0	e1	EFh

↓

Error Flag indicates in 2 figures hexadecimal and returns ASCII code value.	
Example:	e0 e1
■ No Error :	00000000B ⇒ 00h ⇒ 30h 30h
■ Parameter Error :	01010000B ⇒ 50h ⇒ 35h 30h
■ Mode Error :	10010000B ⇒ 90h ⇒ 39h 30h

#### ● Conditions for setting of error flag

Parameter Error	•The designated parameter is an invalid value.
Mode Error	•Not in status of <b>Camera ON</b> . •Not in status of <b>Host Control Mode</b> .



## 14.2 Alarm Output ON

System Control Command Type 1

Function	Sets the alarm output (+/- terminal) to closed.	
Command	0072h	
Parameter	Length	1 byte
	Value	1h
Status	None	
Reference		

### ● Format of Control Code

d0	d1	d2	d3	d4	d5	d6
Header	Device Num	Command	Parameter	End mark		
FFh	30h	3Xh	00h	72h	31h	EFh

### ● Answer Format

d0	d1	d2	d3	d4	d5
Header	Device Num	Error Code	End mark		
FEh	30h	3Xh	e0	e1	EFh

↓

Error Flag indicates in 2 figures hexadecimal and returns ASCII code value.	
Example:	e0 e1
■ No Error :	00000000B ⇒ 00h ⇒ 30h 30h
■ Parameter Error :	01010000B ⇒ 50h ⇒ 35h 30h
■ Mode Error :	10010000B ⇒ 90h ⇒ 39h 30h

### ● Conditions for setting of error flag

Parameter Error	•The designated parameter is an invalid value.
Mode Error	•Not in status of <b>Camera ON</b> . •Not in status of <b>Host Control Mode</b> .

### 14.3 Alarm Output Status Request

System Control Command Type 1

Function	Returns the alarm output setting status.	
Command	0073h	
Parameter	None	
Status	Length	1 byte :
	Value	0h: Alarm output OFF (open) 1h: Alarm output ON (short)
Reference		

● Format of Control Code

d0	d1	d2	d3	d4	d5
Header	Device Num		Command		End mark
FFh	30h	3Xh	00h	73h	EFh

● Answer Format

■ No Error

d0	d1	d2	d3	d4	d5	d6
Header	Device Num		Error Code		Status	End mark
FEh	30h	3Xh	30h	30h	s0	EFh

↓

The setting value is expressed as a one-digit hexadecimal number with the ASCII code as the status value.	
Alarm Output OFF:	0h ⇒ 30h
Alarm Output ON:	1h ⇒ 31h

■ Generated Error

d0	d1	d2	d3	d4	d5
Header	Device Num		Error Code		End mark
FEh	30h	3Xh	e0	e1	EFh

↓

Error Flag indicates in 2 figures hexadecimal and returns ASCII code value.	
Example:	e0 e1
■ Mode Error : 10010000B ⇒ 90h ⇒ 39h 30h	

● Conditions for setting of error flag

Mode Error	<ul style="list-style-type: none"> <li>•Not in status of <b>Camera ON</b>.</li> <li>•Not in status of <b>Host Control Mode</b>.</li> </ul>
------------	--

#### 14.4 External Sensor Input Detection Setting

Function	Sets the input detection of the external sensor.	
Command	0074h	
Parameter	Length	2 byte
	Value	00h: External sensor input detection disabled. 01h: External sensor input detection enabled with notification of changes from Closed to Open. 10h: External sensor input detection enabled with notification of changes from Open to Closed. 11h: External sensor input detection enabled with notification of changes from Closed to Open and notification of changes from Open to Closed.
Status	None	
Reference	•When external sensor input detection enabled is set, the generation of a sensor status change is notified by the event generation code “FB code”.	

● Format of Control Code

d0	d1	d2	d3	d4	d5	d6	d7
Header	Device Num		Command		Parameter		End mark
FFh	30h	3Xh	00h	74h	p0	p1	EFh



Setting value indicates in hexadecimal 2 figures and its ASCII code is Status value.		
External sensor input detection		p0 p1
None:	00h ⇒	30h 30h
Included (Receiving of changes from Closed to Open):	01h ⇒	30h 31h
Included (Receiving of changes from Open to Closed):	10h ⇒	31h 30h
Included (Receiving of all changes):	11h ⇒	31h 31h

● Answer Format

d0	d1	d2	d3	d4	d5
Header	Device Num		Error Code		End mark
FEh	30h	3Xh	e0	e1	EFh



Error Flag indicates in 2 figures hexadecimal and returns ASCII code value.		
Example:		e0 e1
■ No Error :	00000000B ⇒	00h ⇒ 30h 30h
■ Parameter Error :	01010000B ⇒	50h ⇒ 35h 30h
■ Mode Error :	10010000B ⇒	90h ⇒ 39h 30h

● Conditions for setting of error flag

Parameter Error	•In case of assigned parameter illegal.
Mode Error	•Not in status of <b>Camera ON</b> . •Not in status of <b>Host Control Mode</b> .

● Notification Events

d0	d1	d2	d3	d4	d5	d6	d7
Header	Device Num		Command		Status		End mark
FBh	30h	3Xh	00h	74h	30h	30h	EFh

### 14.5 External Sensor Input Detection Status Request System Control Command Type 1

Function	Returns external sensor input detection status.	
Command	0075h	
Parameter	None	
Status	Length	1 byte
	Value	0h: External sensor input terminal status: Closed 1h: External sensor input terminal status: Open
Reference		

● Format of Control Code

d0	d1	d2	d3	d4	d5
Header	Device Num		Command		End mark
FFh	30h	3Xh	00h	75h	EFh

● Answer Format

■ No Error

d0	d1	d2	d3	d4	d5	d6
Header	Device Num		Error Code		Status	End mark
FEh	30h	3Xh	30h	30h	s0	EFh

↓

The detection value is expressed as a one-digit hexadecimal number with the ASCII code as the status value.	
	s0
Input terminal status=Closed:	0h ⇒ 30h
Input terminal status=Open:	1h ⇒ 31h

■ Generated Error

d0	d1	d2	d3	d4	d5
Header	Device Num		Error Code		End mark
FEh	30h	3Xh	e0	e1	EFh

↓

Error Flag indicates in 2 figures hexadecimal and returns ASCII code value.	
Example:	e0 e1
■ Mode Error :	10010000B ⇒ 90h ⇒ 39h 30h

● Conditions for setting of error flag

Mode Error	<ul style="list-style-type: none"> <li>•Not in status of <b>Camera ON</b>.</li> <li>•Not in status of <b>Host Control Mode</b>.</li> </ul>
------------	--

### 14.6 External Sensor Input Detection Setting Information Request System Control Command Type 1

Function	Returns the external sensor input detection setting status.	
Command	0075h	
Parameter	Parameter length	1 byte
	Parameter value	0h
Status	Length	2 byte
	Value	00h: External sensor input detection disabled. 01h: External sensor input detection enabled with notification of changes from Closed to Open. 10h: External sensor input detection enabled with notification of changes from Open to Closed. 11h: External sensor input detection enabled with notification of changes from Closed to Open and notification of changes from Open to Closed.
Reference		

● Format of Control Code

d0	d1	d2	d3	d4	d5	d6
Header	Device Num		Command		Parameter	End mark
FFh	30h	3Xh	00h	75h	30h	EFh

● Answer Format

■ No Error

d0	d1	d2	d3	d4	d5	d6	d7
Header	Device Num		Error Code		Status		End mark
FEh	30h	3Xh	30h	30h	s0	s1	EFh



Setting value indicates in hexadecimal 2 figures and its ASCII code is Status value.		
External sensor input detection		s0 s1
None:	00h ⇒	30h 30h
Included (Receiving of changes from Closed to Open):	01h ⇒	30h 31h
Included (Receiving of changes from Open to Closed):	10h ⇒	31h 30h
Included (Receiving of all changes):	11h ⇒	31h 31h

■ Generated Error

d0	d1	d2	d3	d4	d5
Header	Device Num		Error Code		End mark
FEh	30h	3Xh	e0	e1	EFh



Error Flag indicates in 2 figures hexadecimal and returns ASCII code value.		
Example:		e0 e1
■ Parameter Error :	01010000B ⇒	50h ⇒ 35h 30h
■ Mode Error :	10010000B ⇒	90h ⇒ 39h 30h

● Conditions for setting of error flag

Parameter Error	•In case of assigned parameter illegal.
Mode Error	•Not in status of <b>Camera ON</b> •Not in status of <b>Host Control Mode</b>

## 14.7 Internal Infrared Light ON/OFF Control

System Control Command Type1

Function	Sets the internal infrared light ON/OFF control.	
Command	0076h	
Parameter	Length	1 byte
	Value	0h: Internal infrared light OFF 1h: Internal infrared light ON (automatic OFF after 30 minutes) 2h: Internal infrared light ON (automatic OFF after 1 hour) 3h: Internal infrared light ON (automatic OFF after 2 hours) 4h: Internal infrared light ON (automatic OFF after 3 hours) 5h: Internal infrared light ON (automatic OFF after 4 hours) 6h: Internal infrared light ON (automatic OFF after 8 hours)
Status	None	
Reference	<ul style="list-style-type: none"> <li>•The Light ON command executes the following operations according to the status.</li> <li>(1) If a command is received in the Light OFF status, the Light ON Start and the Automatic OFF Time Set operations are performed.</li> <li>(2) If a command is received in the Light ON status, the Automatic Off Timer Counter Reset and the Automatic Off Time Set operations are performed.</li> <li>•The light cannot be turned on whenever the infrared cut filter is inserted. In this case, a mode error is returned.</li> </ul>	

### ● Format of Control Code

d0	d1	d2	d3	d4	d5	d6
Header	Device Num		Command		Parameter	End mark
FFh	30h	3Xh	00h	76h	p0	EFh



Setting value indicates in hexadecimal 1 figure and its ASCII code is Status value.	
Example:	p0
Light On (automatic OFF after 30 minutes):	1h ⇒ 31h

### ● Answer Format

d0	d1	d2	d3	d4	d5
Header	Device Num		Error Code		End mark
FEh	30h	3Xh	e0	e1	EFh



Error Flag indicates in 2 figures hexadecimal and returns ASCII code value.		
Example:		e0 e1
■ No Error :	00000000B ⇒ 00h ⇒	30h 30h
■ Parameter Error :	01010000B ⇒ 50h ⇒	35h 30h
■ Mode Error :	10010000B ⇒ 90h ⇒	39h 30h

### ● Conditions for setting of error flag

Parameter Error	•In case of assigned parameter illegal.
Mode Error	<ul style="list-style-type: none"> <li>•Not in status of <b>Camera ON</b>.</li> <li>•Not in status of <b>Host Control Mode</b>.</li> <li>•<b>Infrared Cut Filter</b> is inserted.</li> </ul>

## 14.8 Internal Infrared Light Status Request

System Control Command Type 1

Function	Returns the internal infrared light ON/OFF setting status.	
Command	0077h	
Parameter	None	
Status	Length	1 byte
	Value	0h: Internal infrared light OFF 1h: Internal infrared light ON
Reference		

### ● Format of Control Code

d0	d1	d2	d3	d4	d5
Header	Device Num		Command		End mark
FFh	30h	3Xh	00h	77h	EFh

### ● Answer Format

#### ■ No Error

d0	d1	d2	d3	d4	d5	d6
Header	Device Num		Error Code		Status	End mark
FEh	30h	3Xh	30h	30h	s0	EFh

↓

Setting value indicates in hexadecimal 1 figure and its ASCII code is Status value.	
	s0
Internal infrared light OFF:	0h ⇒ 30h
Internal infrared light ON:	1h ⇒ 31h

#### ■ Generated Error

d0	d1	d2	d3	d4	d5
Header	Device Num		Error Code		End mark
FEh	30h	3Xh	e0	e1	EFh

↓

Error Flag indicates in 2 figures hexadecimal and returns ASCII code value.	
Example:	e0 e1
■ Mode Error :	10010000B ⇒ 90h ⇒ 39h 30h

### ● Conditions for setting of error flag

Mode Error	<ul style="list-style-type: none"> <li>•Not in status of <b>Camera ON</b>.</li> <li>•Not in status of <b>Host Control Mode</b>.</li> </ul>
------------	--

## 14.9 External Light Output OFF

System Control Command Type 1

Function	Sets the external light output (+/- terminal) to open.	
Command	0078h	
Parameter	Length	1 byte
	Value	0h
Status	None	
Reference		

### ● Format of Control Code

d0	d1	d2	d3	d4	d5	d6
Header	Device Num		Command		Parameter	End mark
FFh	30h	3Xh	00h	78h	30h	EFh

### ● Answer Format

d0	d1	d2	d3	d4	d5
Header	Device Num		Error Code		End mark
FEh	30h	3Xh	e0	e1	EFh

↓

Error Flag indicates in 2 figures hexadecimal and returns ASCII code value.						
Example:					e0	e1
■ No Error :	00000000B	⇒	00h	⇒	30h 30h	
■ In case of Parameter Error :	01010000B	⇒	50h	⇒	35h 30h	
■ Mode Error :	10010000B	⇒	90h	⇒	39h 30h	

### ● Conditions for setting of error flag

Parameter Error	•In case of assigned parameter illegal.
Mode Error	•Not in status of <b>Camera ON</b> . •Not in status of <b>Host Control Mode</b> .



### 14.10 External Light Output ON

System Control Command Type 1

Function	Sets the external light output (+/- terminal) to closed.	
Command	0078h	
Parameter	Length	1 byte
	Value	1h
Status	None	
Reference		

● Format of Control Code

d0	d1	d2	d3	d4	d5	d6
Header	Device Num		Command		Parameter	End mark
FFh	30h	3Xh	00h	78h	31h	EFh

● Answer Format

d0	d1	d2	d3	d4	d5
Header	Device Num		Error Code		End mark
FEh	30h	3Xh	e0	e1	EFh

↓

Error Flag indicates in 2 figures hexadecimal and returns ASCII code value		
Example:		e0 e1
■ No Error :	00000000B ⇒ 00h ⇒	30h 30h
■ Parameter Error :	01010000B ⇒ 50h ⇒	35h 30h
■ Mode Error :	10010000B ⇒ 90h ⇒	39h 30h

● Conditions for setting of error flag

Parameter Error	•In case of assigned parameter illegal.
Mode Error	•Not in status of <b>Camera ON</b> . •Not in status of <b>Host Control Mode</b> .

### 14.11 External Light Output Status Request

System Control Command Type 1

Function	Returns the setting status of the external light output terminal.	
Command	0079h	
Parameter	None	
Status	Length	1 byte
	Value	0h: External light output OFF (+/- terminal open) 1h: External light output ON (+/- terminal closed)
Reference		

● Format of Control Code

d0	d1	d2	d3	d4	d5
Header	Device Num		Command		End mark
FFh	30h	3Xh	00h	79h	EFh

● Answer Format

■ In case of No Error

d0	d1	d2	d3	d4	d5	d6
Header	Device Num		Error Code		Status	End mark
FEh	30h	3Xh	30h	30h	s0	EFh

↓

The terminal status is expressed as a one-digit hexadecimal number with the ASCII code as the status value.	
External light output OFF (+/- terminal open):	0h ⇒ 30h
External light output ON (+/- terminal closed):	1h ⇒ 31h

■ In case of Error

d0	d1	d2	d3	d4	d5
Header	Device Num		Error Code		End mark
FEh	30h	3Xh	e0	e1	EFh

↓

Error Flag indicates in 2 figures hexadecimal and returns ASCII code value.	
Example:	e0 e1
■ Mode Error :	10010000B ⇒ 90h ⇒ 39h 30h

● Conditions for setting of error flag

Mode Error	<ul style="list-style-type: none"> <li>•Not in status of <b>Camera ON.</b></li> <li>•Not in status of <b>Host Control Mode.</b></li> </ul>
------------	--

## 14.12 Remote Control ON

## System Control Command Type 1

Function	To available remote controller.	
Command	0080h	
Parameter	Length	1 byte
	Value	0h
Status	None	
Reference	<ul style="list-style-type: none"> <li>•To set remote control ON by default during power ON.</li> <li>•By issuing this command, <b>forbidden flag of remote control</b> in operation status comes out zero.</li> <li>•In case of host control mode, receive Key code from remote control even in remote control ON, but not work remote control operation. Operation key code can be confirmed by remote control through command ON. (see <b>9. Function of Remote Control</b>)</li> <li>•In case of local control mode, to operate at key code in status of remote control ON.</li> </ul>	

### ● Format of Control Code

d0	d1	d2	d3	d4	d5	d6
Header	Device Num		Command		Parameter	End mark
FFh	30h	3Xh	00h	80h	30h	EFh

### ● Answer Format

d0	d1	d2	d3	d4	d5
Header	Device Num		Error Code		End mark
FEh	30h	3Xh	e0	e1	EFh



Error Flag indicates in 2 figures hexadecimal and returns ASCII code value.	
Example:	e0 e1
■ In case of No Error :	00000000B ⇒ 00h ⇒ 30h 30h
■ In case of Busy :	00010000B ⇒ 10h ⇒ 31h 30h
■ In case of Parameter Error :	01010000B ⇒ 50h ⇒ 35h 30h
■ In case of Mode Error :	10010000B ⇒ 90h ⇒ 39h 30h

### ● Condition of Error flag to be set

Busy	<ul style="list-style-type: none"> <li>•In case of executing <b>Camera Control</b> command.</li> <li>•In case of executing <b>Pedestal Control</b> command.</li> <li>•In case of executing <b>Preset Move</b> command.</li> </ul>
Parameter Error	•In case of assigned parameter illegal.
Mode Error	<ul style="list-style-type: none"> <li>•Not in status of <b>Camera ON</b>.</li> <li>•Not in status of <b>Host Control Mode</b>.</li> </ul>

### 14.13 Remote Control OFF

System Control Command Type 1

Function	To inhibited remote control	
Command	0080h	
Parameter	Length	1 byte
	Value	1h
Status	None	
Reference	<ul style="list-style-type: none"> <li>•To set remote control ON by default during power ON.</li> <li>•By issuing this command, <b>remote control forbidden flag</b> sets 1 and not receive key code from remote control</li> <li>•Not to execute remote control through operation under remote control OFF, even though <b>remote control through</b> command ON comes out. (See <b>9. Function of Remote Control</b>)</li> </ul>	

#### ● Format of Control Code

d0	d1	d2	d3	d4	d5	d6
Header	Device Num		Command		Parameter	End mark
FFh	30h	3Xh	00h	80h	31h	EFh

#### ● Answer Format

d0	d1	d2	d3	d4	d5
Header	Device Num		Error Code		End mark
FEh	30h	3Xh	e0	e1	EFh



Error Flag indicates in 2 figures hexadecimal and returns ASCII code value		
Example:		e0 e1
■ In case of No Error :	00000000B ⇒ 00h ⇒	30h 30h
■ In case of Busy :	00010000B ⇒ 10h ⇒	31h 30h
■ In case of Parameter Error :	01010000B ⇒ 50h ⇒	35h 30h
■ In case of Mode Error :	10010000B ⇒ 90h ⇒	39h 30h

#### ● Condition of Error flag to be set

Busy	<ul style="list-style-type: none"> <li>•In case of executing <b>Camera Control</b> command.</li> <li>•In case of executing <b>Pedestal Control</b> command.</li> <li>•In case of executing <b>Preset Move</b> command.</li> </ul>
Parameter Error	•In case of assigned parameter illegal.
Mode Error	<ul style="list-style-type: none"> <li>•Not in status of <b>Camera ON</b>.</li> <li>•Not in status of <b>Host Control Mode</b>.</li> </ul>

### 14.14 Operation Status Request

System Control Command Type 1

Function	To return information of inside status of VC-C50i (operation status)																					
Command	0086h																					
Parameter	None																					
Status	Length	3 byte																				
	Value	Value of operation status which indicates inside status (12 bits)																				
Reference	<p>The followings show status, in case that each bit is 1 among of status.</p> <p>(MSB)</p> <p>b11 Tilting under operation</p> <p>b10 Tilt movable limit position</p> <p>b9 Panning under operation</p> <p>b8 Pan movable limit position</p> <p>b7 Zooming under operation</p> <p>b6 Remote Control operate OFF</p> <p>b5 Camera Power OFF</p> <p>b4 Unexecuting Pedestal Initialize</p> <p>b3 Shutter speed flag 1</p> <p>b2 Shutter speed flag 2</p> <table border="0"> <tr> <td>b3</td> <td>b2</td> <td>NTSC</td> <td>PAL</td> </tr> <tr> <td>0</td> <td>0</td> <td>program</td> <td>program</td> </tr> <tr> <td>0</td> <td>1</td> <td>1/60</td> <td>1/50</td> </tr> <tr> <td>1</td> <td>0</td> <td>1/100</td> <td>1/120</td> </tr> <tr> <td>1</td> <td>1</td> <td>Not use</td> <td>Not use</td> </tr> </table> <p>b1 Manual Focus mode</p> <p>b0 Focusing under operation</p> <p>(LSB)</p>		b3	b2	NTSC	PAL	0	0	program	program	0	1	1/60	1/50	1	0	1/100	1/120	1	1	Not use	Not use
b3	b2	NTSC	PAL																			
0	0	program	program																			
0	1	1/60	1/50																			
1	0	1/100	1/120																			
1	1	Not use	Not use																			

● Format of Control Code

d0	d1	d2	d3	d4	d5
Header	Device Num		Command		End mark
FFh	30h	3Xh	00h	86h	EFh

● Answer Format

d0	d1	d2	d3	d4	d5	d6	d7	d8
Header	Device Num		Error Code		Status			End mark
FEh	30h	3Xh	30h	30h	s0	s1	s2	EFh



Inside operation status (12bits) indicated camera inside status indicates in 3 figures hexadecimal and returns ASCII code as status											
Example:											
s0				s1				s2			
b11	b10	b9	b8	b7	b6	b5	b4	b3	b2	b1	b0
0	1	0	0	1	0	0	0	0	0	0	0
"4"				"8"				"0"			
↓				↓				↓			
34h				38h				30h			

● Condition of Error flag to be set

None

### 14.15 Extended Operation Status Request

System Control Command Type 1

Function	To return extended information of inside status of VC-C50i (operation status)																						
Command	0086h																						
Parameter	0h																						
Status	Length	5 byte																					
	Value	Value of operation status which indicates inside status (20 bits)																					
Reference	<p>The followings show status, in case that each bit is 1 among of status.</p> <p>(MSB)</p> <p>b19 In process of Menu</p> <p>b18 Local Control Mode</p> <p>b17 Time unset</p> <p>b16 Date unset</p> <p>b15 Not use</p> <p>b14 Not use</p> <p>b13 Exposure(AE) mode not AUTO</p> <p>b12 White balance mode not AUTO</p> <p>b11 Tilting under operation</p> <p>b10 Tilt movable limit position</p> <p>b9 Panning under operation</p> <p>b8 Pan movable limit position</p> <p>b7 Zooming under operation</p> <p>b6 Remote Control operate OFF</p> <p>b5 Camera Power OFF</p> <p>b4 Unexecuting Pedestal Initialize</p> <p>b3 Shutter speed flag 1</p> <p>b2 Shutter speed flag 2</p> <table border="0"> <tr> <td>b3</td> <td>b2</td> <td>NTSC</td> <td>PAL</td> </tr> <tr> <td>0</td> <td>0</td> <td>program</td> <td>program</td> </tr> <tr> <td>0</td> <td>1</td> <td>1/60</td> <td>1/50</td> </tr> <tr> <td>1</td> <td>0</td> <td>1/100</td> <td>1/120</td> </tr> <tr> <td>1</td> <td>1</td> <td>Not use</td> <td>Not use</td> </tr> </table> <p>b1 Manual Focus mode</p> <p>b0 Focusing under operation</p> <p>(LSB)</p> <p>•The information of b0 ~ b11 is equal to the information of <b>14.14 Operation Status Request</b>.</p> <p>•In case that b19 is 1 (In process of Menu), unable to host control mode.</p> <p>•In case that b18 is 1 (Local Control Mode), unable to control through host.</p>			b3	b2	NTSC	PAL	0	0	program	program	0	1	1/60	1/50	1	0	1/100	1/120	1	1	Not use	Not use
b3	b2	NTSC	PAL																				
0	0	program	program																				
0	1	1/60	1/50																				
1	0	1/100	1/120																				
1	1	Not use	Not use																				

● Format of Control Code

d0	d1	d2	d3	d4	d5	d6
Header	Device Num		Command		Parameter	End mark
FFh	30h	3Xh	00h	86h	30h	EFh

● Answer Format

■ In case of No Error

d0	d1	d2	d3	d4							
Header	Device Num		Error Code								
FEh	30h	3Xh	30h	30h							
			d5	d6	d7	d8	d9	d10			
			Status					End mark			
			s0	s1	s2	s3	s4	EFh			



Inside operation status (20bits) indicated camera inside status indicates in 5 figures hexadecimal and returns ASCII code as status.

Example:

	s0				s1							
	b19	b18	b17	b16	b15	b14	b13	b12				
	1	1	1	1	0	0	0	0				
		"F"				"0"						
		↓				↓						
		46h				30h						
	s3				s4				s5			
	b11	b10	b9	b8	b7	b6	b5	b4	b3	b2	b1	b0
	0	1	0	0	1	0	0	0	0	0	0	0
		"4"				"8"				"0"		
		↓				↓				↓		
		34h				38h				30h		

■ In case of Error

d0	d1	d2	d3	d4	d5
Header	Device Num		Error Code		End mark
FEh	30h	3Xh	e0	e1	EFh



Error Flag indicates in 2 figures hexadecimal and returns ASCII code value.

Example:

■ In case of Parameter Error : 01010000B ⇒ 50h ⇒ 35h 30h

● Condition of Error flag to be set

Parameter Error	•In case of assigned parameter illegal.
-----------------	---

### 14.16 Operation Status 3 Request

System Control Command Type 1

Function	Returns operation status 3.	
Command	0086h	
Parameter	1h	
Status	Length	4 byte
	Value	Based on the operation status (16 bit) value indicating the internal status.
Reference	<p>The following statuses are indicated when each bit in the status is 1.</p> <p>(MSB)</p> <p>b15 Not used (undetermined value)</p> <p>b14 Not used (undetermined value)</p> <p>b13 Not used (undetermined value)</p> <p>b12 Not used (undetermined value)</p> <p>b11 Not used (undetermined value)</p> <p>b10 Not used (undetermined value)</p> <p>b9 Not used (undetermined value)</p> <p>b8 Not used (undetermined value)</p> <p>b7 Displayed on screen (central control) 0: off, 1: on</p> <p>b6 Displayed as user text 0: off, 1: on</p> <p>b5, 4 Displayed date b5 b4</p> <p style="padding-left: 100px;">0 0 : off</p> <p style="padding-left: 100px;">0 1 : Displayed as style 1</p> <p style="padding-left: 100px;">1 0 : Displayed as style 2</p> <p>b3, 2 Displayed time b3 b2</p> <p style="padding-left: 100px;">0 0 : off</p> <p style="padding-left: 100px;">0 1 : Displayed as style 1</p> <p style="padding-left: 100px;">1 0 : Displayed as style 2</p> <p>b1 Date setting completed 0: Not set 1: Setting completed</p> <p>b0 Time setting completed 0: Not set 1: Setting completed</p> <p>(LSB)</p> <p>•The b0, b1 information is identical to the information in <b>14-15. Extended Operation Status Request</b> (b16, b17).</p>	

● Format of Control Code

d0	d1	d2	d3	d4	d5	d6
Header	Device Num	Command	Parameter	End mark		
FFh	30h 3Xh	00h 86h	31h	EFh		



● Answer Format

■ No Error

d0	d1	d2	d3	d4					
Header	Device Num		Error Code						
FEh	30h	3Xh	30h	30h					

d5	d6	d7	d8	d9
Status				End mark
s0	s1	s2	s3	EFh

The operation status (16 bit) indicating the camera internal status is expressed as a four-digit hexadecimal number with the ASCII code returned as the status value.

Example:

s0				s1			
b15	b14	b13	b12	b11	b10	b9	b8
1	1	1	1	1	1	1	1
"F"				"F"			
↓				↓			
46h				46h			

s2				s3			
b7	b6	b5	b4	b3	b2	b1	b0
1	0	0	0	0	0	0	0
"8"				"0"			
↓				↓			
38h				30h			

■ Generated Error

d0	d1	d2	d3	d4	d5
Header	Device Num		Error Code		End mark
FEh	30h	3Xh	e0	e1	EFh

Error Flag indicates in 2 figures hexadecimal and returns ASCII code value.

Example:

		e0	e1
■ Parameter Error :	01010000B	⇒ 50h	⇒ 35h 30h
■ Mode Error :	10010000B	⇒ 90h	⇒ 39h 30h

● Conditions for setting of error flag

Parameter Error	•The designated parameter is an invalid value.
Mode Error	•Not in status of <b>Camera ON</b> . •Not in status of <b>Host Control Mode</b> .

### 14.17 Operation Status 4 Request

System Control Command Type 1

Function	Returns operation status 4.																																																																																							
Command	0086h																																																																																							
Parameter	2h																																																																																							
Status	Length	2 byte																																																																																						
	Value	value of operation status which indicates inside status (8 bits).																																																																																						
Reference	<p>The followings show status, in case that each bit is 1 among of status.</p> <p>(MSB)</p> <p>b7      Blink bit 4  b6      Blink bit 3  b5      Blink bit 2  b4      Blink bit 1  b3      Not used (undetermined value)  b2      Not used (undetermined value)  b1, 0    Color bit            b1      b0</p> <p style="padding-left: 150px;">0      1            : Green LED  1      0            : Red LED  1      1            : Orange LED</p> <p>(LSB)</p> <p>Flashing bit pattern</p> <table border="1" style="margin-left: 40px;"> <thead> <tr> <th>b07</th> <th>b06</th> <th>b05</th> <th>b04</th> <th>Status</th> </tr> </thead> <tbody> <tr><td>1</td><td>1</td><td>1</td><td>1</td><td>Always on</td></tr> <tr><td>1</td><td>1</td><td>1</td><td>0</td><td>6s flashing</td></tr> <tr><td>1</td><td>1</td><td>0</td><td>1</td><td>5s flashing</td></tr> <tr><td>1</td><td>1</td><td>0</td><td>0</td><td>4s flashing</td></tr> <tr><td>1</td><td>0</td><td>1</td><td>1</td><td>3s flashing</td></tr> <tr><td>1</td><td>0</td><td>1</td><td>0</td><td>2s flashing</td></tr> <tr><td>1</td><td>0</td><td>0</td><td>1</td><td>1.5s flashing</td></tr> <tr><td>1</td><td>0</td><td>0</td><td>0</td><td>1s flashing</td></tr> <tr><td>0</td><td>1</td><td>1</td><td>1</td><td>0.8s flashing</td></tr> <tr><td>0</td><td>1</td><td>1</td><td>0</td><td>0.6s flashing</td></tr> <tr><td>0</td><td>1</td><td>0</td><td>1</td><td>0.5s flashing</td></tr> <tr><td>0</td><td>1</td><td>0</td><td>0</td><td>0.4s flashing</td></tr> <tr><td>0</td><td>0</td><td>1</td><td>1</td><td>0.3s flashing</td></tr> <tr><td>0</td><td>0</td><td>1</td><td>0</td><td>0.2s flashing</td></tr> <tr><td>0</td><td>0</td><td>0</td><td>1</td><td>0.1s flashing</td></tr> <tr><td>0</td><td>0</td><td>0</td><td>0</td><td>Off</td></tr> </tbody> </table>			b07	b06	b05	b04	Status	1	1	1	1	Always on	1	1	1	0	6s flashing	1	1	0	1	5s flashing	1	1	0	0	4s flashing	1	0	1	1	3s flashing	1	0	1	0	2s flashing	1	0	0	1	1.5s flashing	1	0	0	0	1s flashing	0	1	1	1	0.8s flashing	0	1	1	0	0.6s flashing	0	1	0	1	0.5s flashing	0	1	0	0	0.4s flashing	0	0	1	1	0.3s flashing	0	0	1	0	0.2s flashing	0	0	0	1	0.1s flashing	0	0	0	0	Off
b07	b06	b05	b04	Status																																																																																				
1	1	1	1	Always on																																																																																				
1	1	1	0	6s flashing																																																																																				
1	1	0	1	5s flashing																																																																																				
1	1	0	0	4s flashing																																																																																				
1	0	1	1	3s flashing																																																																																				
1	0	1	0	2s flashing																																																																																				
1	0	0	1	1.5s flashing																																																																																				
1	0	0	0	1s flashing																																																																																				
0	1	1	1	0.8s flashing																																																																																				
0	1	1	0	0.6s flashing																																																																																				
0	1	0	1	0.5s flashing																																																																																				
0	1	0	0	0.4s flashing																																																																																				
0	0	1	1	0.3s flashing																																																																																				
0	0	1	0	0.2s flashing																																																																																				
0	0	0	1	0.1s flashing																																																																																				
0	0	0	0	Off																																																																																				

● Format of Control Code

d0	d1	d2	d3	d4	d5	d6
Header	Device Num		Command		Parameter	End mark
FFh	30h	3Xh	00h	86h	32h	EFh

● Answer Format

■ In case of No Error

d0	d1	d2	d3	d4	d5	d6	d7
Header	Device Num		Error Code		Status		End mark
FEh	30h	3Xh	30h	30h	s0	s1	EFh



The operation status (8 bit) indicating the camera internal status is expressed as a two-digit hexadecimal number with the ASCII code returned as the status value.

Example:

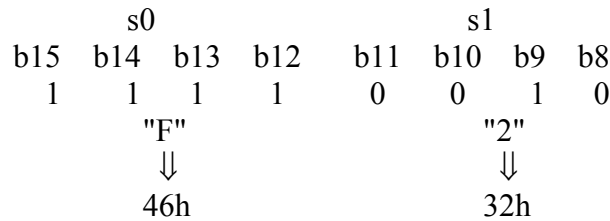

■ Generated Error

d0	d1	d2	d3	d4	d5
Header	Device Num		Error Code		End mark
FEh	30h	3Xh	e0	e1	EFh



Error Flag indicates in 2 figures hexadecimal and returns ASCII code value.

Example:

		e0	e1
■ Parameter Error :	01010000B	⇒ 50h	⇒ 35h 30h
■ Mode Error:	10010000B	⇒ 90h	⇒ 39h 30h

● Condition of Error flag to be set

Parameter Error	•The designated parameter is an invalid value.
Mode Error	•Not in status of <b>Camera ON</b> . •Not in status of <b>Host Control Mode</b> .

### 14.18 Product Name Request

System Control Command Type 1

Function	To return product name	
Command	0087h	
Parameter	None	
Status	Length	5 byte
	Value	"C50i" (43h,35h,30h,69h,20h) "C50iR" (43h,35h,30h,69h,52h)
Reference	To return fixed value	

● Format of Control Code

d0	d1	d2	d3	d4	d5
Header	Device Num		Command		End mark
FFh	30h	3Xh	00h	87h	EFh

● Answer Format

■ In case of No Error

d0	d1	d2	d3	d4						
Header	Device Num		Error Code							
FEh	30h	3Xh	30h	30h						
					d5	d6	d7	d8	d9	d10
					Status					End mark
					s0	s1	s2	s3	s4	EFh
					↓					
		s0	s1	s2	s3	s4				
VCC50i		43h	35h	30h	69h	20h				
VCC50iR		43h	35h	30h	69h	52h				

■ In case of Error

d0	d1	d2	d3	d4	d5
Header	Device Num		Error Code		End mark
FEh	30h	3Xh	e0	e1	EFh

↓

Error Flag indicates in 2 figures hexadecimal and returns ASCII code value.	
Example:	e0 e1
■ In case of Mode Error :	10010000B ⇒ 90h ⇒ 39h 30h

● Condition of Error flag to be set

Mode Error	<ul style="list-style-type: none"> <li>•Not in status of <b>Camera ON.</b></li> <li>•Not in status of <b>Host Control Mode.</b></li> </ul>
------------	--

### 14.19 ROM Version Request

System Control Command Type 1

Function	To return ROM Version of VC-C50i	
Command	0088h	
Parameter	None	
Status	Length	5 byte
	Value	"V1-01" (56h,31h,2Dh,30h,31h)
Reference	The status value (product version + EEPROM version) may be changed in the future.	

● Format of Control Code

d0	d1	d2	d3	d4	d5
Header	Device Num		Command		End mark
FFh	30h	3Xh	00h	88h	EFh

● Answer Format

■ In case of No Error

d0	d1	d2	d3	d4						
Header	Device Num		Error Code							
FEh	30h	3Xh	30h	30h						
					d5	d6	d7	d8	d9	d10
					Status					End mark
					56h	31h	2Dh	30h	31h	EFh

■ In case of Error

d0	d1	d2	d3	d4	d5
Header	Device Num		Error Code		End mark
FEh	30h	3Xh	e0	e1	EFh



Error Flag indicates in 2 figures hexadecimal and returns ASCII code value.	
Example:	e0 e1
■ In case of Mode Error :	10010000B ⇒ 90h ⇒ 39h 30h

● Condition of Error flag to be set

Parameter Error	<ul style="list-style-type: none"> <li>•Not in status of <b>Camera ON</b>.</li> <li>•Not in status of <b>Host Control Mode</b>.</li> </ul>
-----------------	--

## 14.20 Preset Set

## System Control Command Type 1

Function	To store Pan angle (position), Tilt angle (position), zoom position and AE target value (Brightness value) in assigned preset memory address.	
Command	0089h	
Parameter	Length	1 byte
	Value	1~9
Reference	<ul style="list-style-type: none"> <li>•Assign memory address to be stored by parameter value (memory address is position from 1 to 9).</li> <li>•Not to erase stored memory , even though power OFF (to be stored in nonvolatile memory).</li> <li>•Because of using the same memory as preset function of remote control operation, overwrite it, when the same address as memory address assigned by remote controller is assigned.</li> </ul>	

### ● Format of Control Code

d0	d1	d2	d3	d4	d5	d6
Header	Device Num		Command		Parameter	End mark
FFh	30h	3Xh	00h	89h	p0	EFh



Memory address (1~9) to be stored indicates in ASCII 1 byte.
Example: store memory address 1
1            ⇒        01h        ⇒        31h

### ● Answer Format

d0	d1	d2	d3	d4	d5
Header	Device Num		Error Code		End mark
FEh	30h	3Xh	e0	e1	EFh



Error Flag indicates in 2 figures hexadecimal and returns ASCII code value.
Example:
<ul style="list-style-type: none"> <li>■ In case of No Error :                    00000000B ⇒ 00h ⇒ 30h 30h</li> <li>■ In case of Busy :                        00010000B ⇒ 10h ⇒ 31h 30h</li> <li>■ In case of Parameter Error :        01010000B ⇒ 50h ⇒ 35h 30h</li> <li>■ In case of Mode Error :                10010000B ⇒ 90h ⇒ 39h 30h</li> </ul>

### ● Condition of Error flag to be set

Busy	<ul style="list-style-type: none"> <li>•In case of executing <b>Camera Control</b> command.</li> <li>•In case of executing <b>Pedestal Control</b> command.</li> <li>•In case of executing <b>Preset Move</b> command.</li> </ul>
Parameter Error	•In case of assigned parameter outside of 1~9.
Mode Error	<ul style="list-style-type: none"> <li>•Not in status of <b>Camera ON</b>.</li> <li>•Not in status of <b>Host Control Mode</b>.</li> </ul>

## 14.21 Preset Move

## System Control Command Type 2

Function	To move to Pan angle (position), Tilt angle (position), zoom position and AE target value (Brightness value) stored in assigned preset memory address.	
Command	008Ah	
Parameter	Length	1 byte
	Value	1~9
Status	None	
Reference	<ul style="list-style-type: none"> <li>•This command is ineffective until to store preset position by remote control operation or <b>Preset set</b> Command, since nonvolatile memory is unused at the factory shipping moment. (return without answer error)</li> <li>•By issuing this command, start Pan/Tilt/Zoom/AE Target value operations to the assigned Preset position, and flags in <b>operation of Pan/Tilt/Zoom</b> come out 1. When each operation reaches to Preset position, all of operation will stop and corresponding flags be cleared to zero. (Flag corresponding to AE Target Compensation Operation doesn't exist among of status in operation)</li> <li>•Necessary to confirm Termination Notification Answer to this command by setting <b>Command Termination Notification ON</b>, in order to confirm Termination of Shift Operation by this command.</li> <li>•The running speed of this command is reflective of the speed assigned by <b>Pan/Tilt Speed Assignment (12.1,12.2)</b>, <b>Zoom Speed Assignment (13.20)</b> commands.</li> <li>•By this command, Pan/Tilt, Zoom Movement operations or <b>Pan/Tilt Stop</b> command (<b>12.5 or 12.23</b>) stop. But AE target value compensation operation doesn't stop.</li> </ul> <p>Note: After power ON, return mode error and execute <b>Pedestal Initialize 2</b>, at the moment to receive this command without executing <b>Pedestal Initialize 1 &amp; Pedestal Initialize 2</b> commands.</p>	

### ● Format of Control Code

d0	d1	d2	d3	d4	d5	d6
Header	Device Num		Command		Parameter	End mark
FFh	30h	3Xh	00h	8Ah	p0	EFh



Memory address (1~9) to be called indicates in ASCII 1 byte.		
Example: move to Pan/Tilt angle and Zoom position stored in memory address 2		
2	⇒	02h ⇒ p0 32h

● Answer Format

d0	d1	d2	d3	d4	d5
Header	Device Num		Error Code		End mark
FEh	30h	3Xh	e0	e1	EFh



Error Flag indicates in 2 figures hexadecimal and returns ASCII code value.					
Example:					
				e0	e1
■ In case of No Error :	00000000B	⇒	00h	⇒	30h 30h
■ In case of Busy :	00010000B	⇒	10h	⇒	31h 30h
■ In case of Parameter Error :	01010000B	⇒	50h	⇒	35h 30h
■ In case of Mode Error :	10010000B	⇒	90h	⇒	39h 30h

● Condition of Error flag to be set

Busy	<ul style="list-style-type: none"> <li>•In case of executing <b>Camera Control</b> command.</li> <li>•In case of executing <b>Pedestal Control</b> command.</li> <li>•In case of executing <b>Preset Move</b> command.</li> </ul>
Parameter Error	<ul style="list-style-type: none"> <li>•In case of assigned parameter outside of 1~9.</li> </ul>
Mode Error	<ul style="list-style-type: none"> <li>•After Power ON, Not executed Pedestal Initialize.</li> <li>•Not in status of <b>Camera ON</b>.</li> <li>•Not in status of <b>Host Control Mode</b>.</li> </ul>



## 14.22 Preset Status Request

System Control Command Type 1

Function	To return situation in use for memory for Preset position store																	
Command	008Bh																	
Parameter	None																	
Status	Length	2 byte																
	Value	Status value (8 bits) indicating situation in use of memory.																
Reference	<ul style="list-style-type: none"> <li>•This command return information of memory address (1 to 6). If necessary to have 1 to 9 information, need to use <b>14.23 Extended Preset Status Request</b>.</li> <li>•The followings show the case of each bit 1 among of Preset Status,</li> </ul> <p style="text-align: center;">(MBS)</p> <table style="margin-left: auto; margin-right: auto;"> <tr><td>b7</td><td>Memory Address 4 settled</td></tr> <tr><td>b6</td><td>Memory Address 3 settled</td></tr> <tr><td>b5</td><td>Memory Address 2 settled</td></tr> <tr><td>b4</td><td>Memory Address 1 settled</td></tr> <tr><td>b3</td><td>Not used</td></tr> <tr><td>b2</td><td>Not used</td></tr> <tr><td>b1</td><td>Memory Address 6 settled</td></tr> <tr><td>b0</td><td>Memory Address 5 settled</td></tr> </table> <p style="text-align: center;">(LSB)</p>		b7	Memory Address 4 settled	b6	Memory Address 3 settled	b5	Memory Address 2 settled	b4	Memory Address 1 settled	b3	Not used	b2	Not used	b1	Memory Address 6 settled	b0	Memory Address 5 settled
b7	Memory Address 4 settled																	
b6	Memory Address 3 settled																	
b5	Memory Address 2 settled																	
b4	Memory Address 1 settled																	
b3	Not used																	
b2	Not used																	
b1	Memory Address 6 settled																	
b0	Memory Address 5 settled																	

### ● Format of Control Code

d0	d1	d2	d3	d4	d5
Header	Device num		Command		End mark
FFh	30h	3Xh	00h	8Bh	EFh

### ● Answer Format

#### ■ In case of No Error

d0	d1	d2	d3	d4	d5	d6	d7
Header	Device Num		Error Code		Status		End mark
FEh	30h	3Xh	30h	30h	s0	s1	EFh



Status (8bits) indicating situation of memory in use for Preset position store indicates in hexadecimal 2 figures and returns its ASCII code as Status value.	
Example: in case of use of memory address 2 and 3	
01100000B	⇒ 60h ⇒
s0	s1
36h	30h

#### ■ In case of Error

d0	d1	d2	d3	d4	d5
Header	Device Num		Error Code		End mark
FEh	30h	3Xh	e0	e1	EFh



Error Flag indicates in 2 figures hexadecimal and returns ASCII code value.	
Example:	
■ In case of Mode Error :	10010000B ⇒ 90h ⇒ 39h 30h
e0	e1

### ● Condition of Error flag to be set

Mode Error	<ul style="list-style-type: none"> <li>•Not in status of <b>Camera ON</b>.</li> <li>•Not in status of <b>Host Control Mode</b></li> </ul>
------------	---

### 14.23 Extended Preset Status Request

System Control Command Type 1

Function	To return situation in use for memory for preset position store.	
Command	008Bh	
Parameter	0h	
Status	Length	3 byte
	Value	Status value (12 bits) indicating situation in use of memory.
Reference	<p>•The followings show the case of each bit 1 among of preset status.</p> <p>(MSB)</p> <p>b11                    Not used(0)</p> <p>b10                    Not used(0)</p> <p>b9                      Not used(0)</p> <p>b8                      Memory Address 9 settled</p> <p>b7                      Memory Address 8 settled</p> <p>b6                      Memory Address 7 settled</p> <p>b5                      Memory Address 6 settled</p> <p>b4                      Memory Address 5 settled</p> <p>b3                      Memory Address 4 settled</p> <p>b2                      Memory Address 3 settled</p> <p>b1                      Memory Address 2 settled</p> <p>b0                      Memory Address 1 settled</p> <p>(LSB)</p>	

● Format of Control Code

d0	d1	d2	d3	d4	d5	d6
Header	Device Num		Command		Parameter	End mark
FFh	30h	3Xh	00h	8Bh	30h	EFh

● Answer Format

■ In case of No Error

d0	d1	d2	d3	d4	d5	d6	d7	d8
Header	Device Num		Error Code		Status			End mark
FEh	30h	3Xh	30h	30h	s0	s1	s2	EFh



Status (12bits) indicating situation of memory in use for Preset position store indicates in hexadecimal 3 figures and return its ASCII code as Status value.						
Example: In case of use of memory address 2 and 3						
				s0	s1	s2
000000000110B	⇒	006h	⇒	30h	30h	36h

■ In case of Error

d0	d1	d2	d3	d4	d5
Header	Device Num		Error Code		End mark
FEh	30h	3Xh	e0	e1	EFh



Error Flag indicates in 2 figures hexadecimal and returns ASCII code value.					
Example:					
				e0	e1
■ In case of Parameter Error :	01010000B	⇒	50h	⇒	35h 30h
■ In case of Mode Error :	10010000B	⇒	90h	⇒	39h 30h

● Condition of Error flag to be set

Parameter Error	•In case of assigned parameter illegal.
Mode Error	•Not in status of <b>Camera ON</b> . •Not in status of <b>Host Control Mode</b> .

## 14.24 Remote Controller Through Setting

System Control Command Type 1

Function	To switch notification of remote control data ON/OFF	
Command	008Dh	
Parameter	Length	1 byte
	Value	0h: Remote Control Through ON (Admit) 1h: Remote Control Through OFF (Forbid)
Status	None	
Reference	<ul style="list-style-type: none"> <li>•To set remote controller through ON/OFF (Admit/Forbid).</li> <li>•By remote control through ON, to notify received key code from remote control and ON/OFF information to host computer. (See <b>9. Function of Remote Control</b>)</li> <li>•At the moment of power ON, to be in status of remote control through OFF by default.</li> <li>•Not to issue remote control through data even though remote control through ON sets, in case of flag 1 setting in <b>Remote Control Operation</b> forbidden by <b>Remote Control OFF</b> command.</li> <li>•In case of operating by <b>Host Control Mode</b>, not to operate corresponding to received key code from remote controller. (See <b>14.29. Host Control Mode</b> command)</li> <li>•In case of operating by <b>Local Control Mode</b>, to operate corresponding to received key code from remote controller and notify its key code and ON/OFF information.</li> </ul>	

### ● Format of Control Code

d0	d1	d2	d3	d4	d5	d6
Header	Device Num		Command		Parameter	End mark
FFh	30h	3Xh	00h	8Dh	p0	EFh



Remote Control Through (0:ON 1:OFF) indicates in ASCII code 1 byte.	
Example: Remote Control Through OFF (forbid)	p0
1h ⇒	31h

### ● Answer Format

d0	d1	d2	d3	d4	d5
Header	Device Num		Error Code		End mark
FEh	30h	3Xh	e0	e1	EFh



Error Flag indicates in 2 figures hexadecimal and returns ASCII code value.	
Example:	e0 e1
■ In case of No Error :	0000000B ⇒ 00h ⇒ 30h 30h
■ In case of Parameter Error :	0101000B ⇒ 50h ⇒ 35h 30h
■ In case of Mode Error :	1001000B ⇒ 90h ⇒ 39h 30h

### ● Condition of Error flag to be set

Parameter Error	•In case of assigned parameter besides 0 and 1.
Mode Error	•Not in status of <b>Camera ON</b> . •Not in status of <b>Host Control Mode</b> .

## 14.25 LED Normal Display

System Control Command Type 1

Function	To set LED lighting mode under the normal condition.	
Command	008Eh	
Parameter	Length	1 byte
	Value	0h
Status	None	
Reference	•LED normal display comes out by default at the moment of power ON.	

### ● Format of Control Code

d0	d1	d2	d3	d4	d5	d6
Header	Device Num		Command		Parameter	End mark
FFh	30h	3Xh	00h	8Eh	30h	EFh

### ● Answer Format

d0	d1	d2	d3	d4	d5
Header	Device Num		Error Code		End mark
FEh	30h	3Xh	e0	e1	EFh



Error Flag indicates in 2 figures hexadecimal and returns ASCII code value.		
Example:		e0 e1
■ In case of No Error :	0000000B ⇒ 00h	⇒ 30h 30h
■ In case of Parameter Error :	0101000B ⇒ 50h	⇒ 35h 30h
■ In case of Mode Error :	1001000B ⇒ 90h	⇒ 39h 30h

### ● Condition of Error flag to be set

Parameter Error	•In case of assigned parameter illegal .
Mode Error	•Not in status of <b>Host Control Mode</b> .

## LED lighting Status in LED Normal Display Mode

LED Lighting Status		Operating Status
Green ON		Status in Camera ON
Green blinking	0.1 sec cycle	Operating Remote Control buttons
	0.5 sec cycle	Preset Memory Setting, Preset Moving, Menu Setting
	1 sec cycle	Pedestal Initializing, Camera Initializing
Orange ON		Unmatched Remote Control ID
Orange blinking	0.1 sec cycle	Operating remote control with unmatched ID
	0.5 sec cycle	Setting Remote control ID
Red ON		In status of Camera OFF



## 14.27 Cascade OFF

## System Control Command Type 1

Function	To release Cascade Connection OFF.	
Command	008Fh	
Parameter	Length	1 byte
	Value	0h
Status	None	
Reference	<ul style="list-style-type: none"> <li>• Cascade connection status comes out OFF by default at the moment of power ON.</li> <li>• Multiple VC-C50i's unable to control in status of cascade OFF.</li> <li>• Device number of this command is only "3030h"</li> <li>• Usable device number in cascade OFF, is only "3030h"</li> <li>• <b>Cascade ON/OFF</b> commands are effective for all VC-C50i connected even in a cascade OFF status.</li> <li>• To force to stop Pan/Tilt operation by this command except operating pedestal initialize.</li> <li>• Necessary to issue this command before issuing <b>Cascade ON</b> command (<b>14.28</b>).</li> </ul>	

### ● Format of Control Code

d0	d1	d2	d3	d4	d5	d6
Header	Device Num		Command		Parameter	End mark
FFh	30h	30h	00h	8Fh	30h	EFh

### ● Answer Format

d0	d1	d2	d3	d4	d5
Header	Device Num		Error Code		End mark
FEh	30h	30h	e0	e1	EFh

Error Flag indicates in 2 figures hexadecimal and returns ASCII code value.	
Example:	e0 e1
■ In case of No Error :	00000000B ⇒ 00h ⇒ 30h 30h
■ In case of Mode Error :	10010000B ⇒ 90h ⇒ 39h 30h

### ● Condition of Error flag to be set

Mode Error	• In case of operating MENU by <b>Local Mode</b> .
------------	--

## 14.28 Cascade ON

## System Control Command Type 2

Function	To connect cascade connection ON.	
Command	008Fh	
Parameter	Length	1 byte
	Value	1h
Status	None	
Reference	<ul style="list-style-type: none"> <li>• Cascade connection status comes out OFF by default at the moment of power ON.</li> <li>• Multiple VC-C50i (Max. 9 units) able to control by this command .</li> <li>• Necessary to issue this command after issuing <b>Cascade OFF</b> command (14.27).</li> <li>• Device number of this command is only "3030h" fixed.</li> <li>• Connected VC-C50i by this command, comes out <b>Host Control Mode</b>.</li> <li>• Answer by this command is returned with device number of the last VC-C50i connected in cascade.</li> <li>• While Pan/Tilt moving, receiving this command causes busy error, and after that, cascade ON operation will stop for the rest of VC-C50i.</li> <li>• Note: The processing time by this command requires approx. 1 ms per unit and 500 ms for last VC-C50i. (After that, answer will return)</li> <li>• The commands issuing in process of this command will be ignored.</li> <li>• After this process by this command (Cascade On Mode), each VC-C50i will have own device number. (Device number is in order of "3031h", "3032h" .... from computer and "3030h" is Global Command for all)</li> <li>• Only last VC-C50i in cascade connection returns the answer for global command.</li> <li>• By Global Notification Function (<b>7. Cascade Global Notification</b> and <b>14.41 Global Notification Setting</b> command), each error status by global command is known.</li> </ul>	

### ● Format of Control Code

d0	d1	d2	d3	d4	d5	d6
Header	Device Num		Command		Parameter	End mark
FFh	30h	30h	00h	8Fh	31h	EFh

### ● Answer Format

d0	d1	d2	d3	d4	d5
Header	Device Num		Error Code		End mark
FEh	30h	3Xh	e0	e1	EFh



Error Flag indicates in 2 figures hexadecimal and returns ASCII code value.					
Example:					
■ In case of No Error :	00000000B	⇒	00h	⇒	e0 e1
■ In case of Busy :	00010000B	⇒	10h	⇒	31h 30h
■ In case of Mode Error :	10010000B	⇒	90h	⇒	39h 30h

### ● Condition of Error flag to be set

Busy	• In case of executing pedestal Pan/Tilt operation.
Mode Error	• In case of operating MENU by <b>Local Mode</b> .



## 14.29 Host Control Mode

## System Control Command Type 1

Function	To set host control mode.	
Command	0090h	
Parameter	Length	1 byte
	Value	0h
Status	None	
Reference	<ul style="list-style-type: none"> <li>•At the moment of power ON, default sets <b>Local Control Mode</b>.</li> <li>•To be able to control by only host computer through RS-232C and unable to control by remote controller.</li> <li>•<b>Local Control Mode</b> flag in operation status by this command is cleared to 0.</li> <li>•In case to control by remote controller in <b>Host Control Mode</b>, by using remote control through function, possible to control through computer.</li> <li>•In case of entering ID number of remote control or Set number of preset during issuing this command, each input status is forced to release.</li> </ul>	

### ● Format of Control Code

d0	d1	d2	d3	d4	d5	d6
Header	Device Num		Command		Parameter	End mark
FFh	30h	3Xh	00h	90h	30h	EFh

### ● Answer Format

d0	d1	d2	d3	d4	d5
Header	Device Num		Error Code		End mark
FEh	30h	3Xh	e0	e1	EFh



Error Flag indicates in 2 figures hexadecimal and returns ASCII code value.	
Example:	e0 e1
■ In case of No Error :	00000000B ⇒ 00h ⇒ 30h 30h
■ In case of Parameter Error :	01010000B ⇒ 50h ⇒ 35h 30h
■ In case of Mode Error :	10010000B ⇒ 90h ⇒ 39h 30h

### ● Condition of Error flag to be set

Parameter Error	•In case of assigned illegal parameter.
Mode Error	•In case of operating MENU by <b>Local Mode</b> .

### 14.30 Local Control Mode

Function	To set local control mode.	
Command	0090h	
Parameter	Length	1 byte
	Value	1h
Status	None	
Reference	<ul style="list-style-type: none"> <li>•At the moment of power ON, default sets <b>Local Control Mode</b>.</li> <li>•To be controlled by remote control and unable to control by host computer.</li> <li>•In case that flag of <b>Local Control Mode</b> is set 1 among of operating status, all commands except the following commands come out to mode error. <ul style="list-style-type: none"> <li>•<b>Operation Status Request</b> and <b>Extended Operation Status Request</b> commands.</li> <li>•<b>Cascade ON</b> and <b>Cascade OFF</b> commands</li> <li>•<b>Host Control Mode</b> and <b>Local Control Mode</b> commands</li> </ul> </li> <li>•In case of remote control receipt forbidden by <b>Remote Control OFF</b> command before issuing this command, remote control operation is forbidden, even in <b>Local Control Mode</b> status.</li> <li>•In case of <b>Remote Control Through</b> Function ON by <b>Remote Control Through Assignment</b> command before issuing this command, to control by remote control and notify its information to host computer.</li> </ul>	

● Format of Control Code

d0	d1	d2	d3	d4	d5	d6
Header	Device Num		Command		Parameter	End mark
FFh	30h	3Xh	00h	90h	31h	EFh

● Answer Format

d0	d1	d2	d3	d4	d5
Header	Device Num		Error Code		End mark
FEh	30h	3Xh	e0	e1	EFh



Error Flag indicates in 2 figures hexadecimal and returns ASCII code value.					
Example:					
■ In case of No Error :	00000000B	⇒	00h	⇒	e0 e1
■ In case of Parameter Error :	01010000B	⇒	50h	⇒	35h 30h
■ In case of Mode Error :	10010000B	⇒	90h	⇒	39h 30h

● Condition of Error flag to be set

Parameter Error	•In case of assigned illegal parameter.
Mode Error	•In case of operating MENU by <b>Local Mode</b> .

### 14.31 Screen Control

### System Control Command Type 1

Function	To control screen display of date, time, characters.																																															
Command	0091h																																															
Parameter	Length	2 byte																																														
	Range	00h~09h																																														
Status	None																																															
Reference	<p>•The following display indication can be set, Parameter</p> <table style="margin-left: 40px;"> <tr> <td>00h : Display Indication OFF</td> <td>(Screen Display OFF)</td> </tr> <tr> <td>01h : Display Indication ON</td> <td>(Screen Display ON)</td> </tr> <tr> <td>02h : Character Indication OFF</td> <td></td> </tr> <tr> <td>03h : Character Indication ON</td> <td></td> </tr> <tr> <td>04h : Time Indication OFF</td> <td></td> </tr> <tr> <td>05h : Time Indication ON 1</td> <td>(Indication Format 1)</td> </tr> <tr> <td>06h : Time Indication ON 2</td> <td>(Indication Format 2)</td> </tr> <tr> <td>07h : Date Indication OFF</td> <td></td> </tr> <tr> <td>08h : Date Indication ON 1</td> <td>(Indication Format 1)</td> </tr> <tr> <td>09h : Date Indication ON 2</td> <td>(Indication Format 2)</td> </tr> </table> <p>•At the moment of power ON, display indication OFF, character indication ON, time indication ON2, date indication ON2 are set by default.</p> <p>•By display indication ON/OFF control, all function able to be controlled, even though each of character indication, time indication, date indication is set ON/OFF.</p> <p>•Time Indication Format has two type as under,</p> <table style="margin-left: 40px;"> <tr> <td>Indication Format 1</td> <td>hh : mm : ss</td> </tr> <tr> <td>Indication Format 2</td> <td>HH : mm : ss AP</td> </tr> <tr> <td>hh</td> <td>⇒ Hour (00~24)</td> </tr> <tr> <td>HH</td> <td>⇒ Hour (00~12)</td> </tr> <tr> <td>mm</td> <td>⇒ Minute (00~59)</td> </tr> <tr> <td>ss</td> <td>⇒ Second (00~59)</td> </tr> <tr> <td>AP</td> <td>⇒ AM or PM</td> </tr> </table> <p>•Date Indication Format has two type as under,</p> <table style="margin-left: 40px;"> <tr> <td>Indication Format 1</td> <td>yy : mm : dd</td> </tr> <tr> <td>Indication Format 2</td> <td>dd : MM : yy</td> </tr> <tr> <td>yy</td> <td>⇒ Year (00~99)</td> </tr> <tr> <td>mm</td> <td>⇒ Month (01~12)</td> </tr> <tr> <td>MM</td> <td>⇒ Month (JAN, FEB, MAR, APL, MAY, JUN, JUL, AUG, SEP, OCT, NOV, DEC)</td> </tr> <tr> <td>dd</td> <td>⇒ Date (01~31)</td> </tr> </table> <p>Note: At the moment of power ON, time indication &amp; date indication start flashing when display indication sets ON before setting of time &amp; date.</p>		00h : Display Indication OFF	(Screen Display OFF)	01h : Display Indication ON	(Screen Display ON)	02h : Character Indication OFF		03h : Character Indication ON		04h : Time Indication OFF		05h : Time Indication ON 1	(Indication Format 1)	06h : Time Indication ON 2	(Indication Format 2)	07h : Date Indication OFF		08h : Date Indication ON 1	(Indication Format 1)	09h : Date Indication ON 2	(Indication Format 2)	Indication Format 1	hh : mm : ss	Indication Format 2	HH : mm : ss AP	hh	⇒ Hour (00~24)	HH	⇒ Hour (00~12)	mm	⇒ Minute (00~59)	ss	⇒ Second (00~59)	AP	⇒ AM or PM	Indication Format 1	yy : mm : dd	Indication Format 2	dd : MM : yy	yy	⇒ Year (00~99)	mm	⇒ Month (01~12)	MM	⇒ Month (JAN, FEB, MAR, APL, MAY, JUN, JUL, AUG, SEP, OCT, NOV, DEC)	dd	⇒ Date (01~31)
00h : Display Indication OFF	(Screen Display OFF)																																															
01h : Display Indication ON	(Screen Display ON)																																															
02h : Character Indication OFF																																																
03h : Character Indication ON																																																
04h : Time Indication OFF																																																
05h : Time Indication ON 1	(Indication Format 1)																																															
06h : Time Indication ON 2	(Indication Format 2)																																															
07h : Date Indication OFF																																																
08h : Date Indication ON 1	(Indication Format 1)																																															
09h : Date Indication ON 2	(Indication Format 2)																																															
Indication Format 1	hh : mm : ss																																															
Indication Format 2	HH : mm : ss AP																																															
hh	⇒ Hour (00~24)																																															
HH	⇒ Hour (00~12)																																															
mm	⇒ Minute (00~59)																																															
ss	⇒ Second (00~59)																																															
AP	⇒ AM or PM																																															
Indication Format 1	yy : mm : dd																																															
Indication Format 2	dd : MM : yy																																															
yy	⇒ Year (00~99)																																															
mm	⇒ Month (01~12)																																															
MM	⇒ Month (JAN, FEB, MAR, APL, MAY, JUN, JUL, AUG, SEP, OCT, NOV, DEC)																																															
dd	⇒ Date (01~31)																																															

● Format of Control Code

d0	d1	d2	d3	d4	d5	d6	d7
Header	Device Num		Command		Parameter		End mark
FFh	30h	3Xh	00h	91h	p0	p1	EFh



Status of display indication indicates in hexadecimal 2 figures and returns its ASCII code as value.			
Example: Display Indication ON (All Display ON)		p0	p1
	01h	⇒	30h 31h
Date Indication ON2 (Indication Format 2)		p0	p1
	09h	⇒	30h 39h

● Answer Format

d0	d1	d2	d3	d4	d5
Header	Device Num		Error Code		End mark
FEh	30h	3Xh	e0	e1	EFh



Error Flag indicates in 2 figures hexadecimal and returns ASCII code value.			
Example:		e0	e1
■ In case of No Error :	00000000B	⇒	00h ⇒ 30h 30h
■ In case of Parameter Error :	01010000B	⇒	50h ⇒ 35h 30h
■ In case of Mode Error :	10010000B	⇒	90h ⇒ 39h 30h

● Condition of Error flag to be set

Parameter Error	•In case of assigned parameter besides 00h~09h.
Mode Error	•Not in status of <b>Camera ON</b> . •Not in status of <b>Host Control Mode</b> .

### 14.32 Display Character Data Assignment

Function	To set character data to be indicated in the display.			
Command	0091h			
Parameter	Length	6 byte		
	Range	Position to be indicated	Horizontal	00h~17h
			Vertical	0h~Ah
		Indicated Character Code	20h~5Fh	
Status	None			
Reference	<ul style="list-style-type: none"> <li>The character data to be indicated are as followings. <ul style="list-style-type: none"> <li>p0 Fixed value ⇒ 31h</li> <li>p1, p2 Horizontal position ⇒ 0~23 (00h~17h)</li> <li>p3 Vertical position ⇒ 0~10 (0h~Ah)</li> <li>p4, p5 Character Code ⇒ 32~95 (20h~5Fh)</li> </ul> </li> <li>See next page (<b>Display Indication Character Code Table</b>) concerning character code.</li> <li>At the moment of power ON, indicating range comes out blank data (5Fh)</li> </ul> <p>Note:</p> <ul style="list-style-type: none"> <li>Not to be indicated, even though character data is set in the following range since time &amp; date are indicated within 10 characters × 2 lines at the lower right display corner. (Horizontal position: 14~23, Vertical lines: 9~10)</li> </ul>			

● Format of Control Code

d0	d1	d2	d3	d4	d5	d6	d7	d8	d9	d10	d11
Header	Device Num		Command		Fixed	Horizontal		Vertical	Character Code		End mark
FFh	30h	3Xh	00h	91h	31h	p1	p2	p3	p4	p5	EFh



Character indication position and character data indicates in hexadecimal 5 figures and parameter value is its ASCII code.
Example: to character "A" in the range of Horizontal 20, Vertical 5
14h 5h 41h ⇒ p1 p2 p3 p4 p5 31h 34h 35h 34h 31h

● Answer Format

d0	d1	d2	d3	d4	d5
Header	Device Num		Error Code		End mark
FEh	30h	3Xh	e0	e1	EFh



Error Flag indicates in 2 figures hexadecimal and returns ASCII code value.
Example:
<ul style="list-style-type: none"> <li>In case of No Error : 0000000B ⇒ 00h ⇒ 30h 30h</li> <li>In case of Parameter Error : 0101000B ⇒ 50h ⇒ 35h 30h</li> <li>In case of Mode Error : 1001000B ⇒ 90h ⇒ 39h 30h</li> </ul>

● Condition of Error flag to be set

Parameter Error	•In case of assigned parameter outside range.
Mode Error	•Not in status of <b>Camera ON</b> . •Not in status of <b>Host Control Mode</b> .

### Display Indication Character Code Table

Indicated Character	Character Code	ASCII code	Indicated Character	Character Code	ASCII code
0	30h	33.30h	A	41h	34.31h
1	31h	33.31h	B	42h	34.32h
2	32h	33.32h	C	43h	34.33h
3	33h	33.33h	D	44h	34.34h
4	34h	33.34h	E	45h	34.35h
5	35h	33.35h	F	46h	34.36h
6	36h	33.36h	G	47h	34.37h
7	37h	33.37h	H	48h	34.38h
8	38h	33.38h	I	49h	34.39h
9	39h	33.39h	J	4Ah	34.41h
			K	4Bh	34.42h
Space	20h	32.30h	L	4Ch	31.43h
!	21h	32.31h	M	4Dh	34.44h
(	28h	32.38h	N	4Eh	34.45h
)	29h	32.39h	O	4Fh	34.46h
+	2Bh	32.42h	P	50h	35.30h
-	2Dh	32.44h	Q	51h	35.31h
.	2Eh	32.45h	R	52h	35.32h
/	2Fh	32.46h	S	53h	35.33h
:	3Ah	33.41h	T	54h	35.34h
;	3Bh	33.42h	U	55h	35.35h
<	3Ch	33.43h	V	56h	35.36h
>	3Eh	33.45h	W	57h	35.37h
?	3Fh	33.46h	X	58h	35.38h
			Y	59h	35.39h
Blank	5Fh	35.36h	Z	5Ah	35.41h

Note: Character Code "5Fh" indicating "Blank" is equivalent to "\_"

### 14.33 Display Character Data Request

System Control Command Type 1

Function	To read character data to be indicated in the display.			
Command	0091h			
Parameter	Length	4 byte		
	Range	Position to be indicated	Horizontal	00h~17h
			Vertical	0h~Ah
Status	Length	2 byte		
	Range	32~95 (20h~5Fh)		
Reference	<ul style="list-style-type: none"> <li>The character data to be indicated are as followings. <ul style="list-style-type: none"> <li>p0 Fixed vale ⇒ 32h</li> <li>p1, p2 Horizontal position ⇒ 0~23 (00h~17h)</li> <li>p3 Vertical position ⇒ 0~10 (0h~Ah)</li> </ul> </li> <li>See previous page (<b>Display Indication Character Code Table</b>) concerning character code.</li> <li>At the moment of power ON, indicating range comes out blank data (5Fh). Note:</li> <li>Not to be indicated, even though character data is set in the following range since time &amp; date are indicated within 10 characters × 2 lines at the lower right display corner. (Horizontal position: 14~23, Vertical lines: 9~10)</li> </ul>			

● Format of Control Code

d0	d1	d2	d3	d4	d5	d6	d7	d8	d9
Header	Device Num	Command	Fixed	Horizontal	Vertical	End mark			
FFh	30h	3Xh	00h	91h	32h	p1	p2	p3	EFh



Character indication position indicates in hexadecimal 3 figures and parameter value is its ASCII code.								
Example: to read of Horizontal 20, Vertical 5								
<table style="margin-left: auto; margin-right: auto;"> <tr> <td></td> <td>p1</td> <td>p2</td> <td>p3</td> </tr> <tr> <td>14h 5h</td> <td>⇒ 31h</td> <td>34h</td> <td>35h</td> </tr> </table>		p1	p2	p3	14h 5h	⇒ 31h	34h	35h
	p1	p2	p3					
14h 5h	⇒ 31h	34h	35h					





### 14.34 Display Date Assignment

Function	To set date data to be indicated in the display.		
Command	0091h		
Parameter	Length	7 byte	
	Range	Year Data	0~99
		Month Data	1~12
		Day Data	1~31
Status	None		
Reference	<ul style="list-style-type: none"> <li>•The Date data to be indicated are as followings. <ul style="list-style-type: none"> <li>p0 Fixed vale ⇒ 33h</li> <li>p1~ p2 Year Data ⇒ 00h~99h</li> <li>p3~ p4 Month Data ⇒ 01h~12h</li> <li>p5~ p6 Day Data ⇒ 01h~31h</li> </ul> </li> <li>•At the moment of power ON, to be set 00 year 01 month 01 day by default.</li> <li>•Setting data is set BCD type hexadecimal. (20 in decimal equal to 20h)</li> <li>•Date setting data is to be directly set in inside Clock IC.</li> </ul>		

● Format of Control Code

d0	d1	d2	d3	d4					
Header	Device Num		Command						
FFh	30h	3Xh	00h	91h					
	d5	d6	d7	d8	d9	d10	d11	d12	
	Fixed	Year Data		Month Data		Day data		End mark	
	33h	p1	p2	p3	p4	p5	p6	EFh	



Date data indicates in BCD type hexadecimal 6 figures and parameter value is its ASCII code.

Example:  
year00 month07day25 ⇒ p1 p2 p3 p4 p5 p6  
30h 30h 30h 37h 32h 35h

● Answer Format

d0	d1	d2	d3	d4	d5
Header	Device Num		Error Code		End mark
FEh	30h	3Xh	e0	e1	EFh



Error Flag indicates in 2 figures hexadecimal and returns ASCII code value.

Example:  
e0 e1  
■ In case of No Error : 00000000B ⇒ 00h ⇒ 30h 30h  
■ In case of Parameter Error : 01010000B ⇒ 50h ⇒ 35h 30h  
■ In case of Mode Error : 10010000B ⇒ 90h ⇒ 39h 30h

● Condition of Error flag to be set

Parameter Error	•In case of assigned parameter outside range.
Mode Error	•Not in status of <b>Camera ON</b> . •Not in status of <b>Host Control Mode</b> .

### 14.35 Display Date Request

System Control Command Type 1

Function	To request date data (year, month, day).	
Command	0091h	
Parameter	Length	1 byte
	Value	34h
Status	Length	6 byte
	Value	Year (2 byte) + Month (2 byte) + Day (2 byte)
Reference	<ul style="list-style-type: none"> <li>•The date data to be returned as followings. <ul style="list-style-type: none"> <li>s0~ s1 Year Data ⇒ 00h~99h</li> <li>s2~ s3 Month Data ⇒ 01h~12h</li> <li>s4~ s5 Day Data ⇒ 01h~31h</li> </ul> </li> <li>•At the moment of power ON, to be set 00 year 01 month 01 day by default</li> <li>•Setting data is set BCD type hexadecimal. (20 in decimal equal to 20h)</li> <li>•Date setting data is to be directly read out from inside Clock IC.</li> </ul>	

● Format of Control Code

	d0	d1	d2	d3	d4	d5	d6
Header	Device Num		Command		Parameter	End mark	
FFh	30h	3Xh	00h	91h	34h	EFh	

● Answer Format

■ In case of No Error

	d0	d1	d2	d3	d4						
Header	Device Num		Error Code								
FEh	30h	3Xh	30h	30h							
			d5	d6	d7	d8	d9	d10	d11		
			Year Data		Month Data		Day data		End mark		
			s0	s1	s2	s3	s4	s5	EFh		



Date data indicates in BCD type hexadecimal 6 figures and status value is its ASCII code.
Example: year00 month07 day25 ⇒ s0 s1 s2 s3 s4 s5 30h 30h 30h 37h 32h 35h

■ In case of Error

	d0	d1	d2	d3	d4	d5
Header	Device Num		Error Code		End mark	
FEh	30h	3Xh	e0	e1	EFh	



Error Flag indicates in 2 figures hexadecimal and returns ASCII code value
Example: <ul style="list-style-type: none"> <li>■ In case of Parameter Error : 01010000B ⇒ 50h ⇒ 35h 30h</li> <li>■ In case of Mode Error : 10010000B ⇒ 90h ⇒ 39h 30h</li> </ul>

● Condition of Error flag to be set

Parameter Error	•In case of assigned illegal parameter.
Mode Error	•Not in status of <b>Camera ON</b> •Not in status of <b>Host Control Mode</b>

### 14.36 Display Time Setting

### System Control Command Type 1

Function	To set time data (hour, minute, second) to be indicated in the display.		
Command	0091h		
Parameter	Length	7 byte	
	Range	Hour Data	0~23
		Minute Data	0~59
	Second Data	0~59	
Status	None		
Reference	<ul style="list-style-type: none"> <li>•The time data to be indicated are as followings. <ul style="list-style-type: none"> <li>p0 Fixed ⇒ 35h</li> <li>p1~ p2 Hour Data ⇒ 00h~23h</li> <li>p3~ p4 Minute Data ⇒ 00h~59h</li> <li>p5~ p6 Second Data ⇒ 00h~59h</li> </ul> </li> <li>•At the moment of power ON, to be set 00 hour 00 minute 00 second by default.</li> <li>•Setting data is set BCD type hexadecimal. (20 in decimal equal to 20h)</li> <li>•Time setting data is to be directly set in inside Clock IC.</li> </ul>		

#### ● Format of Control Code

d0	d1	d2	d3	d4					
Header	Device Num		Command						
FFh	30h	3Xh	00h	91h					
	d5	d6	d7	d8	d9	d10	d11	d12	
	Fixed	Hour Data		Minute Data		Second data		End mark	
	35h	p1	p2	p3	p4	p5	p6	EFh	



Time data indicates in BCD type hexadecimal 6 figures and parameter value is its ASCII code.
Example: hour17 minute30 second25 ⇒ p1 p2 p3 p4 p5 p6 31h 37h 33h 30h 32h 35h

#### ● Answer Format

d0	d1	d2	d3	d4	d5
Header	Device Num		Error Code		End mark
FEh	30h	3Xh	e0	e1	EFh



Error Flag indicates in 2 figures hexadecimal and returns ASCII code value.
Example: <ul style="list-style-type: none"> <li>■ In case of No Error : 00000000B ⇒ 00h ⇒ 30h 30h</li> <li>■ In case of Parameter Error : 01010000B ⇒ 50h ⇒ 35h 30h</li> <li>■ In case of Mode Error : 10010000B ⇒ 90h ⇒ 39h 30h</li> </ul>

#### ● Condition of Error flag to be set

Parameter Error	•In case of assigned parameter outside range.
Mode Error	•Not in status of <b>Camera ON</b> . •Not in status of <b>Host Control Mode</b> .

### 14.37 Display Time Request

System Control Command Type 1

Function	To request time data (hour, minute, second) indicated display.	
Command	0091h	
Parameter	Length	1 byte
	Value	36h
Status	Length	6 byte
	Value	hour (2 byte) + minute (2 byte) + second (2byte)
Reference	<ul style="list-style-type: none"> <li>•The Time data to be set as followings. <ul style="list-style-type: none"> <li>s0~ s1 Hour Data ⇒ 00h~23h</li> <li>s2~ s3 Minute Data ⇒ 00h~59h</li> <li>s4~ s5 Second Data ⇒ 00h~59h</li> </ul> </li> <li>•At the moment of power ON, to be set 00 hour 00 minute 00 second by default.</li> <li>•Setting data is set BCD type hexadecimal. (20 in decimal equal to 20h)</li> <li>•Time setting data is to be directly read out from inside Clock IC.</li> </ul>	

● Format of Control Code

d0	d1	d2	d3	d4	d5	d6
Header	Device Num		Command		Parameter	End mark
FFh	30h	3Xh	00h	91h	36h	EFh

● Answer Format

■ In case of No Error

d0	d1	d2	d3	d4				
Header	Device Num		Error Code					
FEh	30h	3Xh	30h	30h				
		d5	d6	d7	d8	d9	d10	d11
		Hour Data		Minute Data		Second Data		End mark
		s0	s1	s2	s3	s4	s5	EFh

↓

Time data indicates in BCD type hexadecimal 6 figures and status value is its ASCII code.  
Example:  
hour17 minute30 second25 ⇒ 31h 37h 33h 30h 32h 35h

■ In case of Error

d0	d1	d2	d3	d4	d5
Header	Device Num		Error Code		End mark
FEh	30h	3Xh	e0	e1	EFh

↓

Error Flag indicates in 2 figures hexadecimal and returns ASCII code value.  
Example:  
■ In case of Parameter Error : 01010000B ⇒ 50h ⇒ 35h 30h  
■ In case of Mode Error : 10010000B ⇒ 90h ⇒ 39h 30h

● Condition of Error flag to be set

Parameter Error	•In case of assigned parameter illegal.
Mode Error	•Not in status of <b>Camera ON</b> . •Not in status of <b>Host Control Mode</b> .



### 14.39 Default Setting

Function	To initialize in status of factory setting.	
Command	0093h	
Parameter	Length	1 byte
	Value	0h
Status	None	
Reference	<ul style="list-style-type: none"> <li>•To return to status of factory setting at shipping from factory. (to re-write memory data of built in nonvolatile IC)</li> <li>•By this command, all items except the followings reset default values at the shipping status from factory. <ul style="list-style-type: none"> <li>•Pedestal Initial Information</li> <li>•Date, Time setting</li> <li>•Indication Character setting</li> </ul> </li> <li>•By this command, camera section is rest.</li> <li>•By this command, communication section with host is reinitialized. (Baud rate: 9600 bps, stop: 1 bit)</li> <li>•Host Control Mode unchanged, but cascade OFF status comes out.</li> <li>•By this command, CTS signal of host stop one second OFF.</li> </ul> <p>Note:</p> <ul style="list-style-type: none"> <li>•Necessary to issue another commands after two seconds passed from issuing this command.</li> </ul>	

● Format of Control Code

d0	d1	d2	d3	d4	d5	d6
Header	Device Num		Command		Parameter	End mark
FFh	30h	3Xh	00h	93h	30h	EFh

● Answer Format

d0	d1	d2	d3	d4	d5
Header	Device Num		Error Code		End mark
FEh	30h	3Xh	e0	e1	EFh



Error Flag indicates in 2 figures hexadecimal and returns ASCII code value.	
Example:	e0 e1
■ In case of No Error :	0000000B ⇒ 00h ⇒ 30h 30h
■ In case of Busy :	0001000B ⇒ 10h ⇒ 31h 30h
■ In case of Parameter Error :	0101000B ⇒ 50h ⇒ 35h 30h
■ In case of Mode Error :	1001000B ⇒ 90h ⇒ 39h 30h

● Condition of Error flag to be set

Busy	<ul style="list-style-type: none"> <li>•In case of executing of <b>Camera Control</b> command.</li> <li>•In case of executing <b>Pedestal Control</b> command.</li> <li>•In case of executing <b>Preset Move</b> command.</li> </ul>
Parameter Error	•In case of assigned parameter except 0h.
Mode Error	<ul style="list-style-type: none"> <li>•Not in status of <b>Camera ON</b>.</li> <li>•Not in status of <b>Host Control Mode</b>.</li> </ul>

### 14.40 Command Termination Notification Setting

System Control Command Type 1

Function	To set command termination notification ON/OFF after command type 2 completion.	
Command	0094h	
Parameter	Length	1 byte
	Value	0h: OFF (not Notify) 1h: ON (Notify)
Status	None	
Reference	<ul style="list-style-type: none"> <li>•At the moment of power ON, to OFF by default.</li> <li>•Command termination notification comes out to effective at the command after issuing this command.</li> <li>•See <b>Communication Timing Diagram (3.3)</b>, <b>Function of Command Termination Notification (6)</b>, <b>Classification by Execution Format (10.2)</b>.</li> </ul>	

● Format of Control Code

d0	d1	d2	d3	d4	d5	d6
Header	Device Num		Command		Parameter	End mark
FFh	30h	3Xh	00h	94h	p0	EFh



Command termination notification ON/OFF indicates in ASCII code 1 byte.
Example: to notify command termination notification p0 01h ⇒ 31h

● Answer Format

d0	d1	d2	d3	d4	d5
Header	Device Num		Error Code		End mark
FEh	30h	3Xh	e0	e1	EFh



Error Flag indicates in 2 figures hexadecimal and returns ASCII code value.
Example:
<ul style="list-style-type: none"> <li>■ In case of No Error : 00000000B ⇒ 00h ⇒ 30h 30h</li> <li>■ In case of Parameter Error : 01010000B ⇒ 50h ⇒ 35h 30h</li> <li>■ In case of Mode Error : 10010000B ⇒ 90h ⇒ 39h 30h</li> </ul>

● Condition of Error flag to be set

Parameter Error	•In case of assigned parameter except 0h or 1h.
Mode Error	<ul style="list-style-type: none"> <li>•Not in status of <b>Camera ON</b>.</li> <li>•Not in status of <b>Host Control Mode</b>.</li> </ul>

### 14.41 Global Notification Setting

System Control Command Type 1

Function	To set global notification ON/OFF after cascaded global command.	
Command	0095h	
Parameter	Length	1 byte
	Value	0h: OFF (not Notify) 1h: ON (Notify)
Status	None	
Reference	<ul style="list-style-type: none"> <li>•At the moment of power ON, to OFF by default.</li> <li>•To notify each error to global command in cascade status ON, in case of global notification ON.</li> <li>•Global notification comes out to effective in case of cascade ON. (See <b>14.28.Cascade On</b> command)</li> <li>•Global notification ON comes out effective to the command after issuing this command.</li> <li>•Last device set by <b>Cascade Connection ON</b> command notify this command.</li> <li>•See <b>Cascade Global Notification (7)</b>.</li> </ul>	

● Format of Control Code

d0	d1	d2	d3	d4	d5	d6
Header	Device Num		Command		Parameter	End mark
FFh	30h	30h	00h	95h	p0	EFh



Global notification ON/OFF indicates in ASCII code 1 byte.
Example: to notify global notification p0 01h ⇒ 31h

● Answer Format

d0	d1	d2	d3	d4	d5
Header	Device Num		Error Code		End mark
FEh	30h	3Xh	e0	e1	EFh



Error Flag indicates in 2 figures hexadecimal and returns ASCII code value.
Example:
<ul style="list-style-type: none"> <li>■ In case of No Error : 00000000B ⇒ 00h ⇒ 30h 30h</li> <li>■ In case of Parameter Error : 01010000B ⇒ 50h ⇒ 35h 30h</li> <li>■ In case of Mode Error : 10010000B ⇒ 90h ⇒ 39h 30h</li> </ul>

● Condition of Error flag to be set

Parameter Error	•In case of assigned parameter except 0h or 1h.
Mode Error	•Not in status of <b>Host Control Mode</b> .



## 14.42 Pedestal Model Request

System Control Command Type 1

Function	To return pedestal model (Normal model, Inverse model)	
Command	009Ah	
Parameter	Length	1 byte
	Value	0h
Status	Length	1 byte
	Value	0h: Normal model, 1h: Inverse model
Reference		

### ● Format of Control Code

d0	d1	d2	d3	d4	d5	d6
Header	Device Num		Command		Parameter	End mark
FFh	30h	3Xh	00h	9Ah	30h	EFh

### ● Answer Format

#### ■ In case of No Error

d0	d1	d2	d3	d4	d5	d6
Header	Device Num		Error Code		Status	End mark
FEh	30h	3Xh	30h	30h	s0	EFh

#### ■ In case of Error

d0	d1	d2	d3	d4	d5
Header	Device Num		Error Code		End mark
FEh	30h	3Xh	e0	e1	EFh



Error Flag indicates in 2 figures hexadecimal and returns ASCII code value.	
Example:	e0 e1
■ In case of Parameter Error :	01010000B ⇒ 50h ⇒ 35h 30h

### ● Condition of Error flag to be set

Parameter Error	•In case of assigned parameter except 0h.
-----------------	---

### 14.43 Camera Model Request

System Control Command Type 1

Function	To return camera model (NTSC, PAL)	
Command	009Ah	
Parameter	Length	1 byte
	Value	1h
Status	Length	1 byte
	Value	0h: NTSC, 1h: PAL
Reference		

● Format of Control Code

d0	d1	d2	d3	d4	d5	d6
Header	Device Num		Command		Parameter	End mark
FFh	30h	3Xh	00h	9Ah	31h	EFh

● Answer Format

■ In case of No Error

d0	d1	d2	d3	d4	d5	d6
Header	Device Num		Error Code		Status	End mark
FEh	30h	3Xh	30h	30h	s0	EFh

■ In case of Error

d0	d1	d2	d3	d4	d5
Header	Device Num		Error Code		End mark
FEh	30h	3Xh	e0	e1	EFh



Error Flag indicates in 2 figures hexadecimal and returns ASCII code value.
Example: <span style="float: right;">e0 e1</span>
■ In case of Parameter Error : 01010000B ⇒ 50h ⇒ 35h 30h

● Condition of Error flag to be set

Parameter Error	•In case of assigned parameter except 1h.
-----------------	---

## 15. Connection Cable

### 15.1 Example 1 Connection with PC-AT

DSUB type with 25 pins

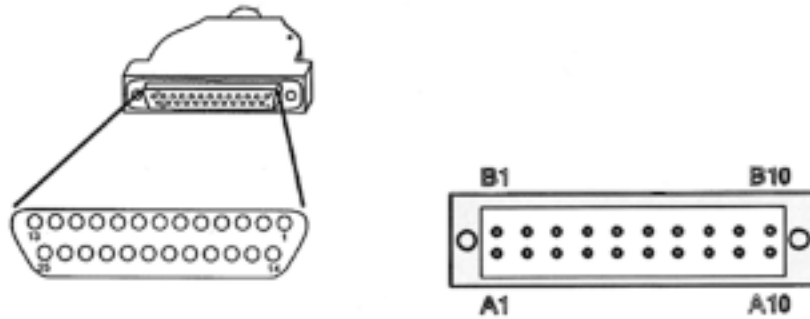

PC-AT  
25 pins  
DSUB (Female)

Camera  
20 pins  
B2L 3.5/20 LH SN OR (Female)

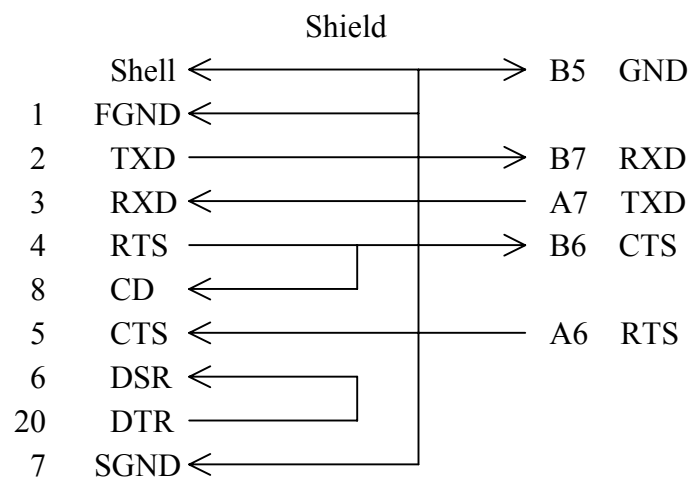

## 15.2 Example 2 Connection with PC-AT

9 pins DSUB type

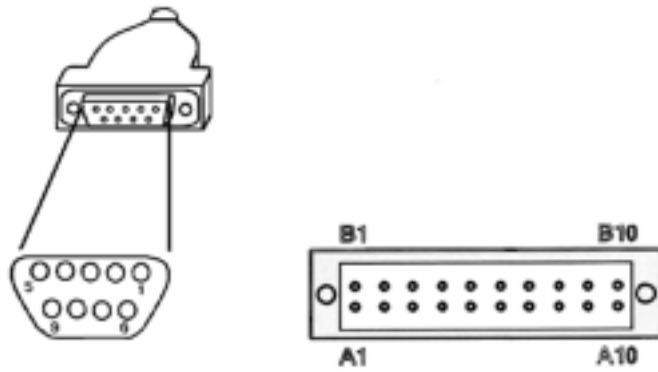

PC-AT	Camera
9 pins	20 pins
DSUB (Female)	B2L 3.5/20 LH SN OR (Female)

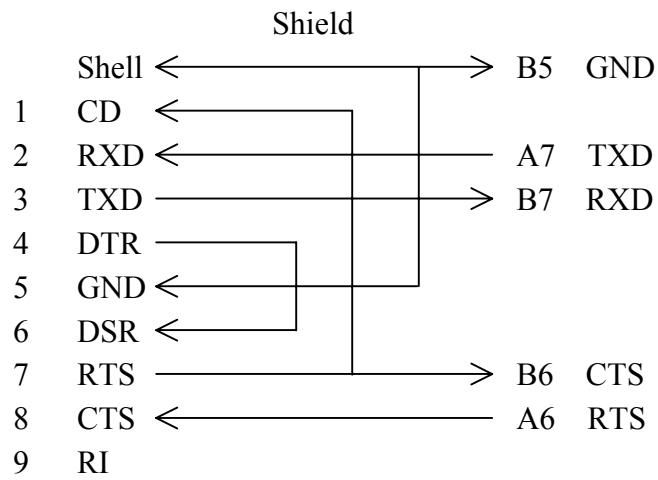

### 15.3 Example Connection with Macintosh

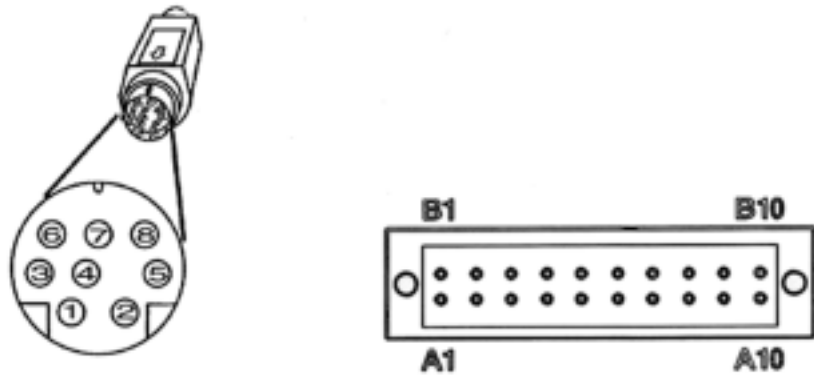

Personal computer 8 pins Mini DIN connector (Male)	Camera 20 pins B2L 3.5/20 LH SN OR (Female)
--	---

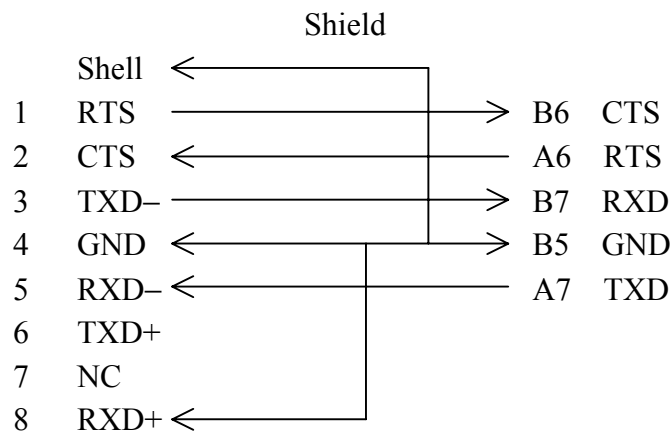

### 15.4 Example of Connection Cables for Computer Side of VC-C50i

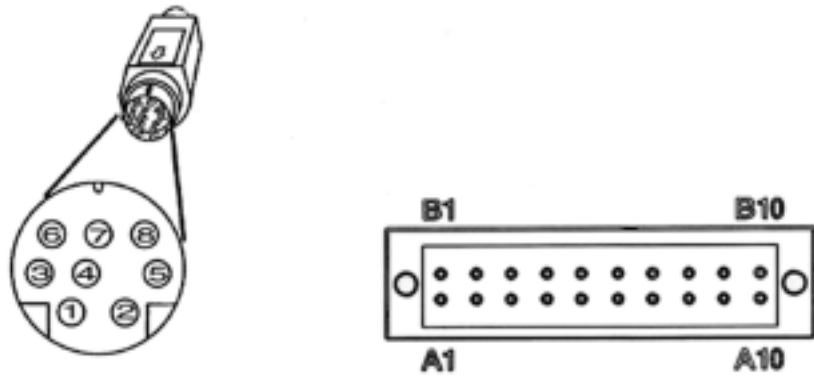

Computer side VC-C50i  
8 pins  
Mini-DIN connector (Male)

Camera side  
20 pins  
B2L 3.5/20 LH SN OR (Female)

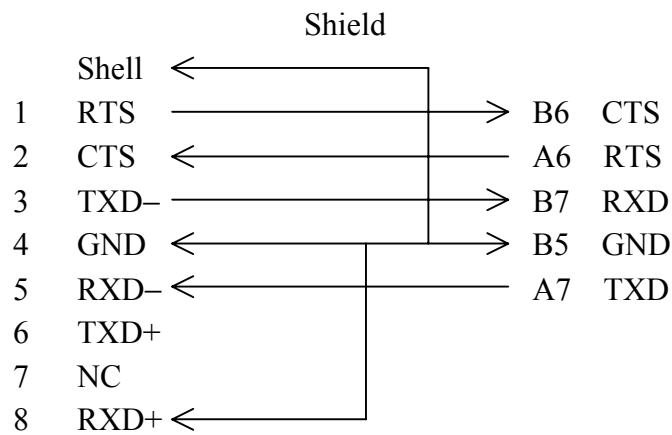

### 15.5 Example of Connection Cables for Next Camera Side of VC-C50i

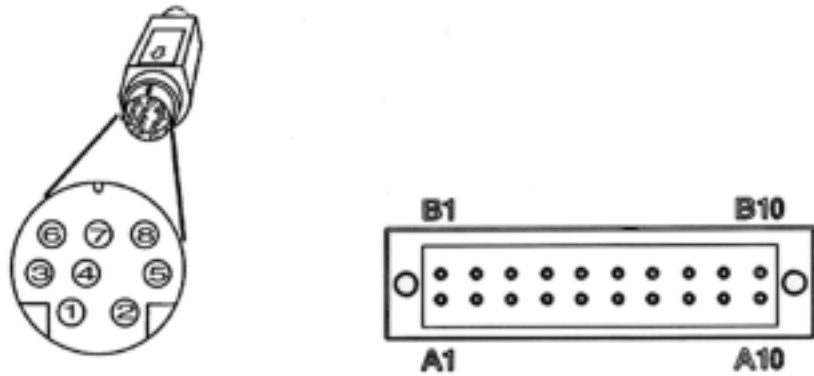

Next camera side VC-C50i	Camera
8 pins	20 pins
Mini-DIN connector (Male)	B2L 3.5/20 LH SN OR (Female)

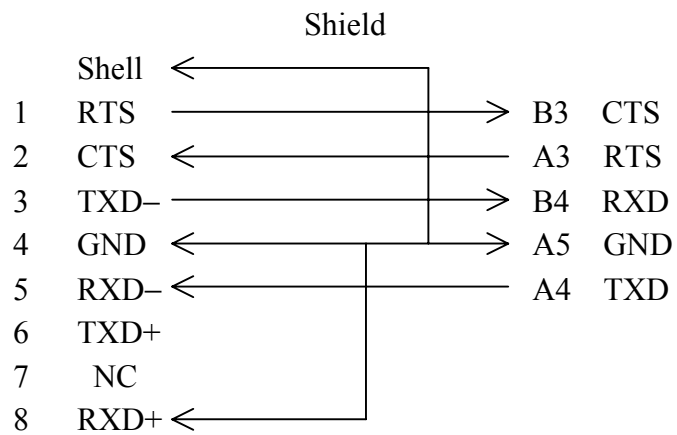

15.6 Example of Connection Cables from VC-C50i to VC-C50i

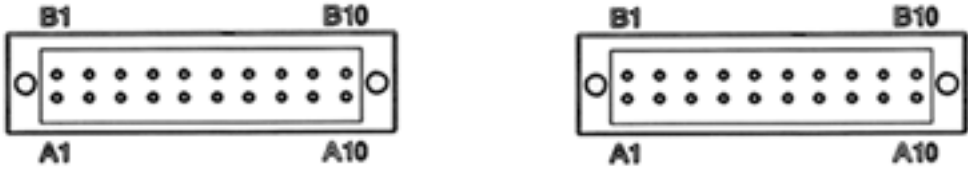

Computer side VC-C50i

20pins

B2L 3.5/20 LH SN OR (Female)

Camera side VC-C50i

20 pins

B2L 3.5/20 LH SN OR (Female)





## 16. Example of Host Control Sequence

### 16.1 Assignment of Host Control Mode

In case of VC-C50i controlled by host, Necessary to change VC-C50i control mode.  
By local control mode flag (bit 18) of operation status, the current mode can be found  
host control mode or local control mode.

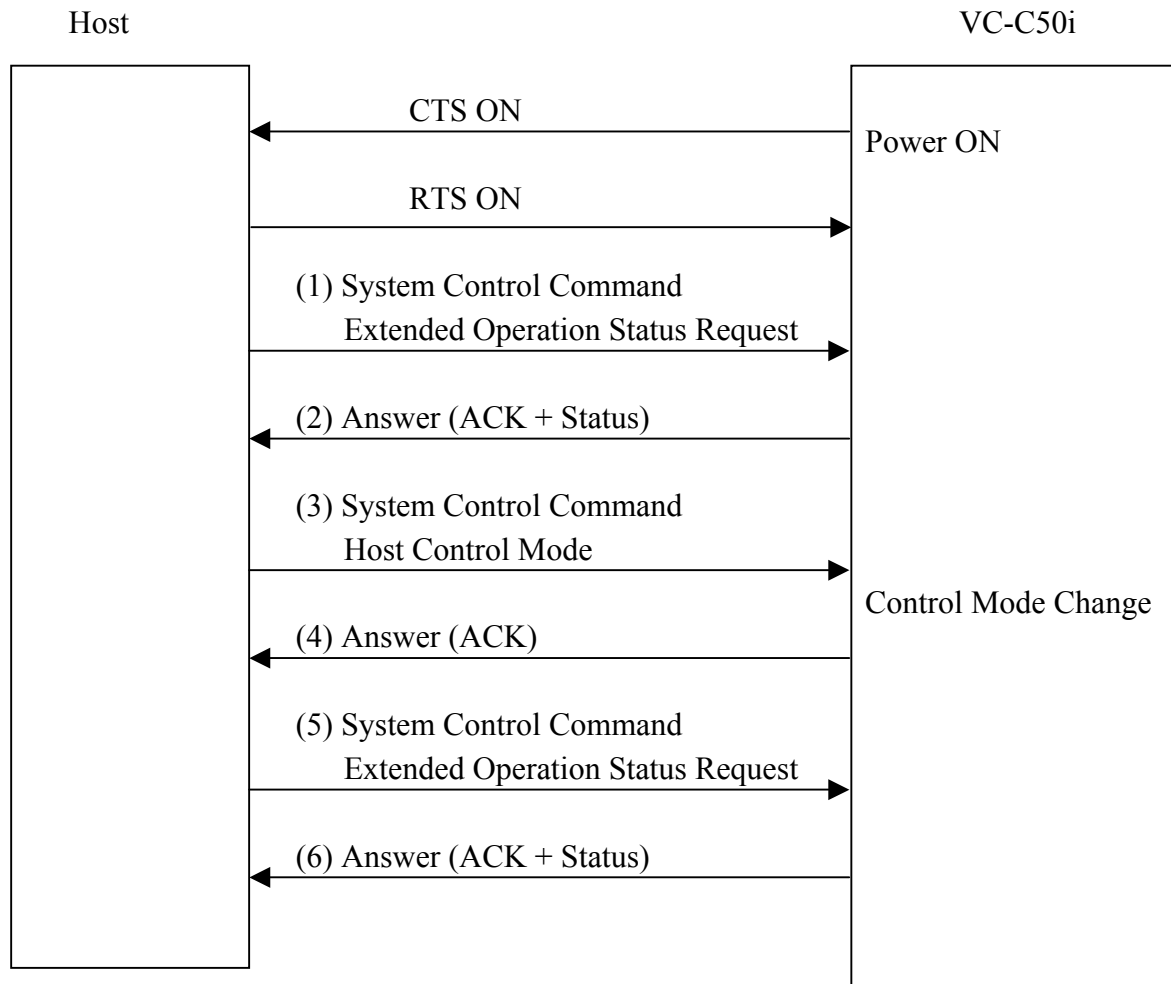

#### Corresponding Frame Code

	Command/Answer
(1)	FF 30 30 00 86 30 EF
(2)	FE 30 30 30 30 37 30 30 31 30 EF
(3)	FF 30 30 00 90 30 EF
(4)	FE 30 30 30 30 EF
(5)	FF 30 30 00 86 30 EF
(6)	FE 30 30 30 30 33 30 30 3130 EF

## 16.2 Initial Setting

In case of power ON, it is necessary to pedestal initialize at first.

In case of using date and time, it is necessary to set the present time and date.

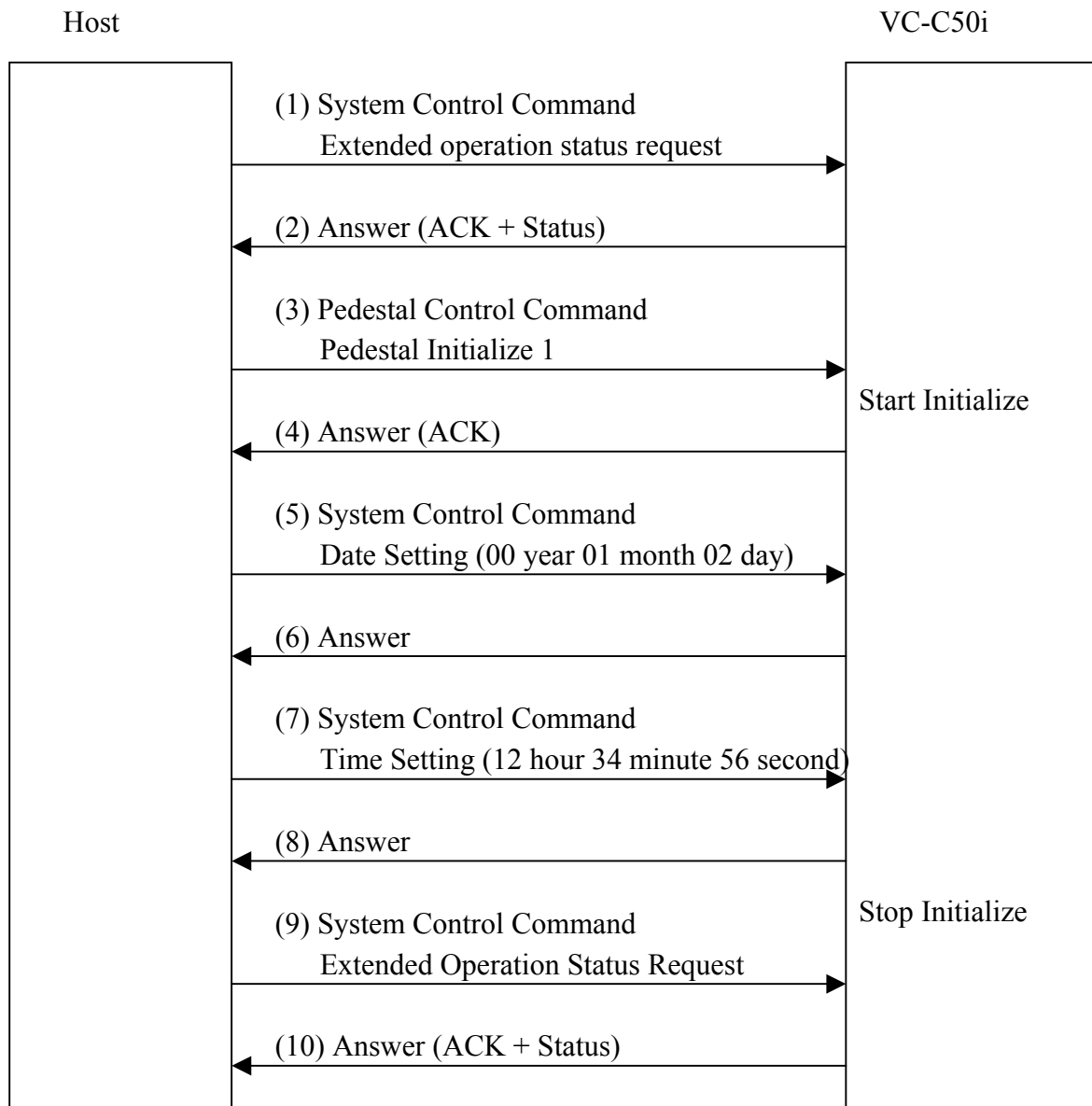

### Corresponding Frame Code

	Command/Answer
(1)	FF 30 30 00 86 30 EF
(2)	FE 30 30 30 30 33 30 30 31 30 EF
(3)	FF 30 30 00 58 30 EF
(4)	FE 30 30 30 30 EF
(5)	FF 30 30 00 91 33 30 30 30 31 30 32 EF
(6)	FE 30 30 30 30 EF
(7)	FF 30 30 00 91 35 31 32 33 34 35 36 EF
(8)	FE 30 30 30 30 EF
(9)	FF 30 30 00 86 30 EF
(10)	FE 30 30 30 30 30 30 30 30 EF

### 16.3 Command Termination Notification

Example Command Termination Notification ON

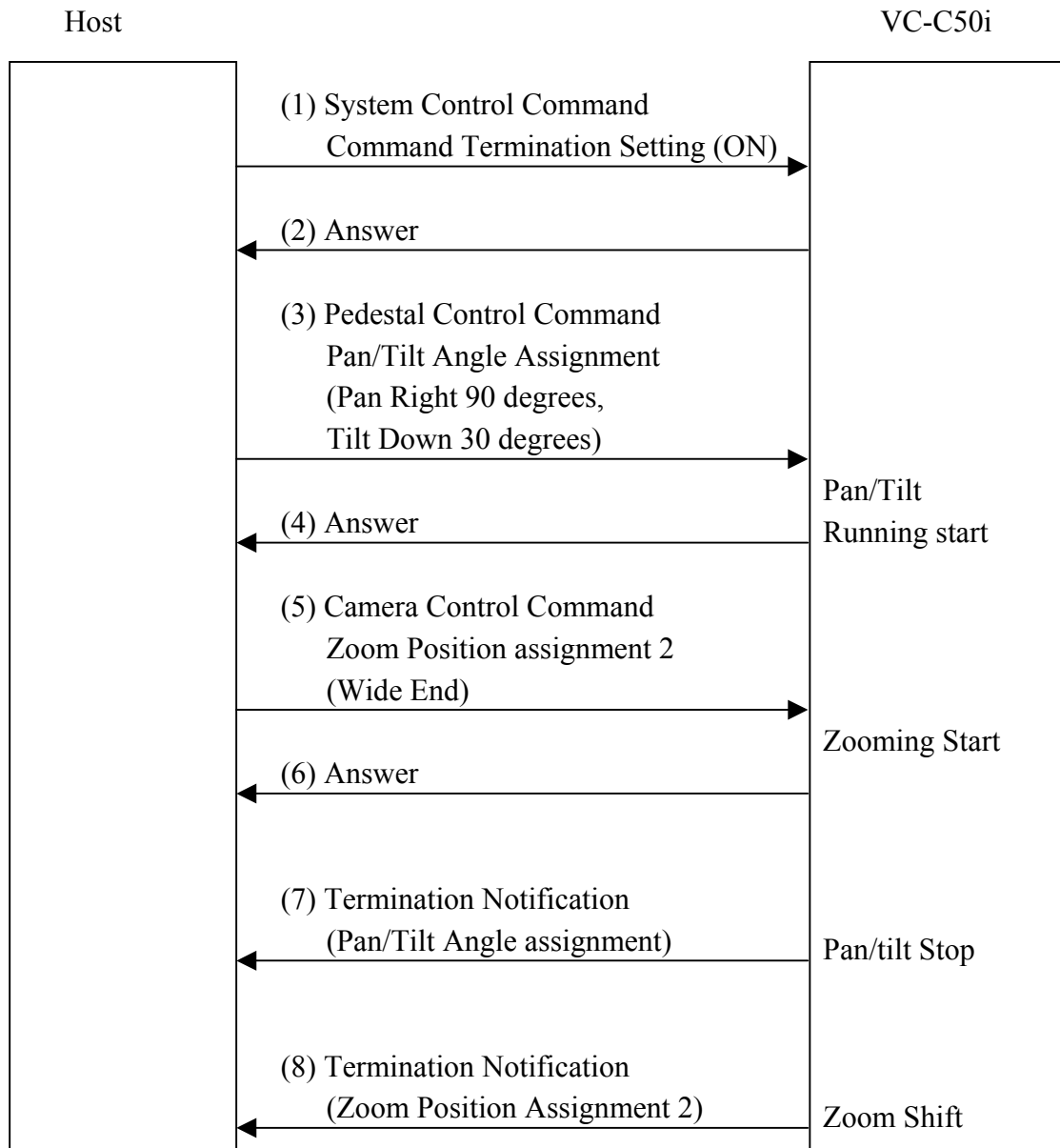

#### Corresponding Frame Code

	Command/Answer
(1)	FF 30 30 00 94 31 EF
(2)	FE 30 30 30 30 EF
(3)	FF 30 30 00 62 38 33 32 30 37 45 46 35 EF
(4)	FE 30 30 30 30 EF
(5)	FF 30 30 00 B3 30 30 30 30 EF
(6)	FE 30 30 30 30 EF
(7)	FA 30 30 00 62 38 33 32 30 37 45 46 35 EF
(8)	FA 30 30 00 B3 30 30 30 30 EF

## 16.4 Remote Controller Through

Example of Remote Control Through ON

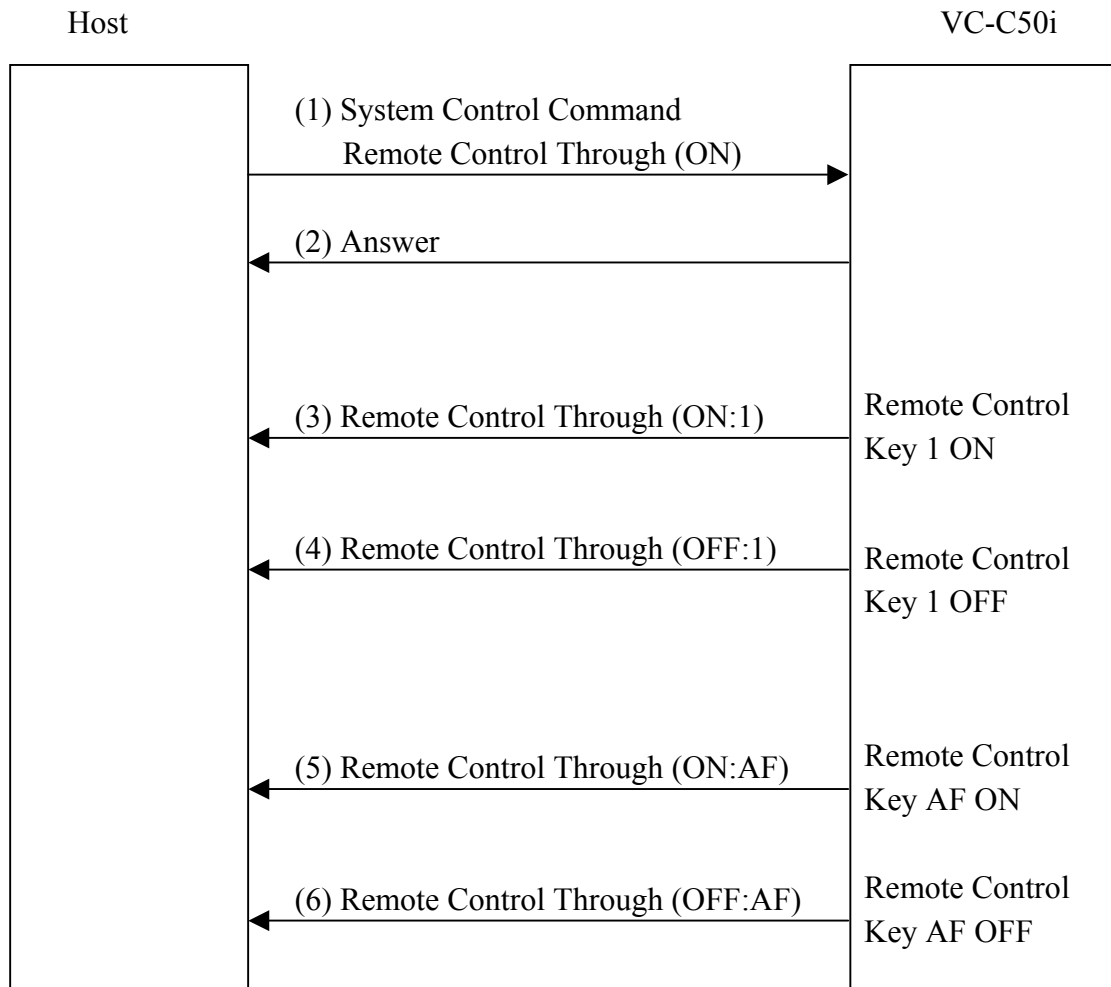

### Corresponding Frame Code

	Command/Answer
(1)	FF 30 30 00 8D 30 EF
(2)	FE 30 30 30 30 EF
(3)	FD 30 30 30 31 EF
(4)	FC 30 30 30 31 EF
(5)	FD 30 30 30 37 EF
(6)	FC 30 30 30 37 EF

### 16.5 Cascade ON Assignment

In case of VC-C50i controlled by Host, Cascade ON Command comes out to Host Control Mode even under Host Control Mode.

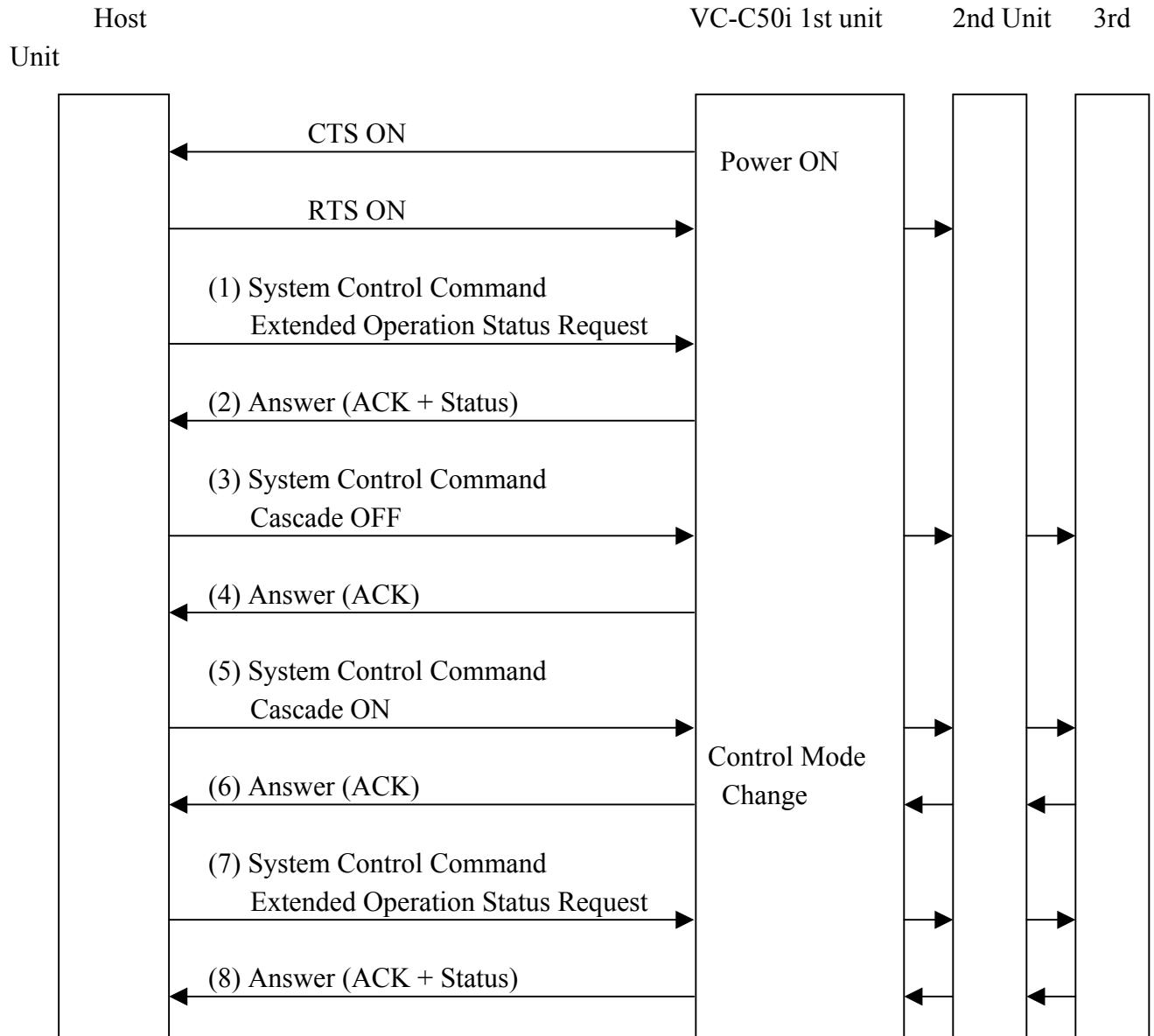

#### Corresponding Frame Code

	Command/Answer
(1)	FF 30 30 00 86 30 EF
(2)	FE 30 30 30 30 37 30 30 31 30 EF
(3)	FF 30 30 00 8F 30 EF
(4)	FE 30 30 30 30 EF
(5)	FF 30 30 00 8F 31 EF
(6)	FE 30 33 30 30 EF
(7)	FF 30 30 00 86 30 EF
(8)	FE 30 33 30 30 33 30 30 31 30 EF

## 16.6 Cascade Individual Assignment

In case of VC-C50i controlled individually, it is necessary to assign Device Number

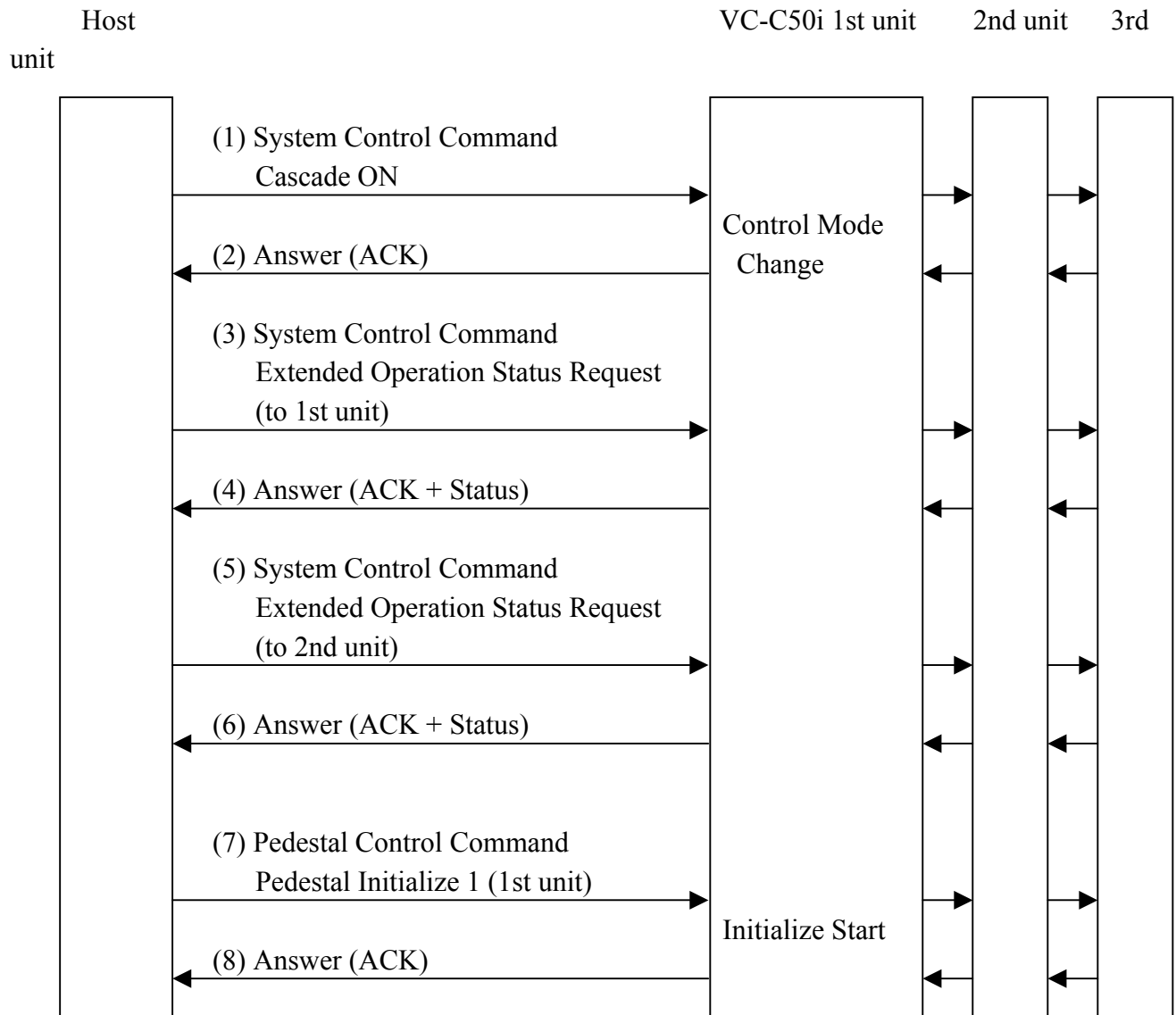

### Corresponding Frame Code

	Command/Answer
(1)	FF 30 30 00 8F 31 EF
(2)	FE 30 33 30 30 EF
(3)	FF 30 31 00 86 30 EF
(4)	FE 30 31 30 30 33 30 30 31 30 EF
(5)	FF 30 32 00 86 30 EF
(6)	FE 30 32 30 30 33 30 30 31 30 EF
(7)	FF 30 31 00 58 30 EF
(8)	FE 30 31 30 30 EF

## 16.7 Cascade Global Assignment

In case of VC-C50i controlled simultaneously in cascade connection, it is necessary to assign device num "3030"

Example of Termination Notification ON, Global Notification ON by Cascade ON

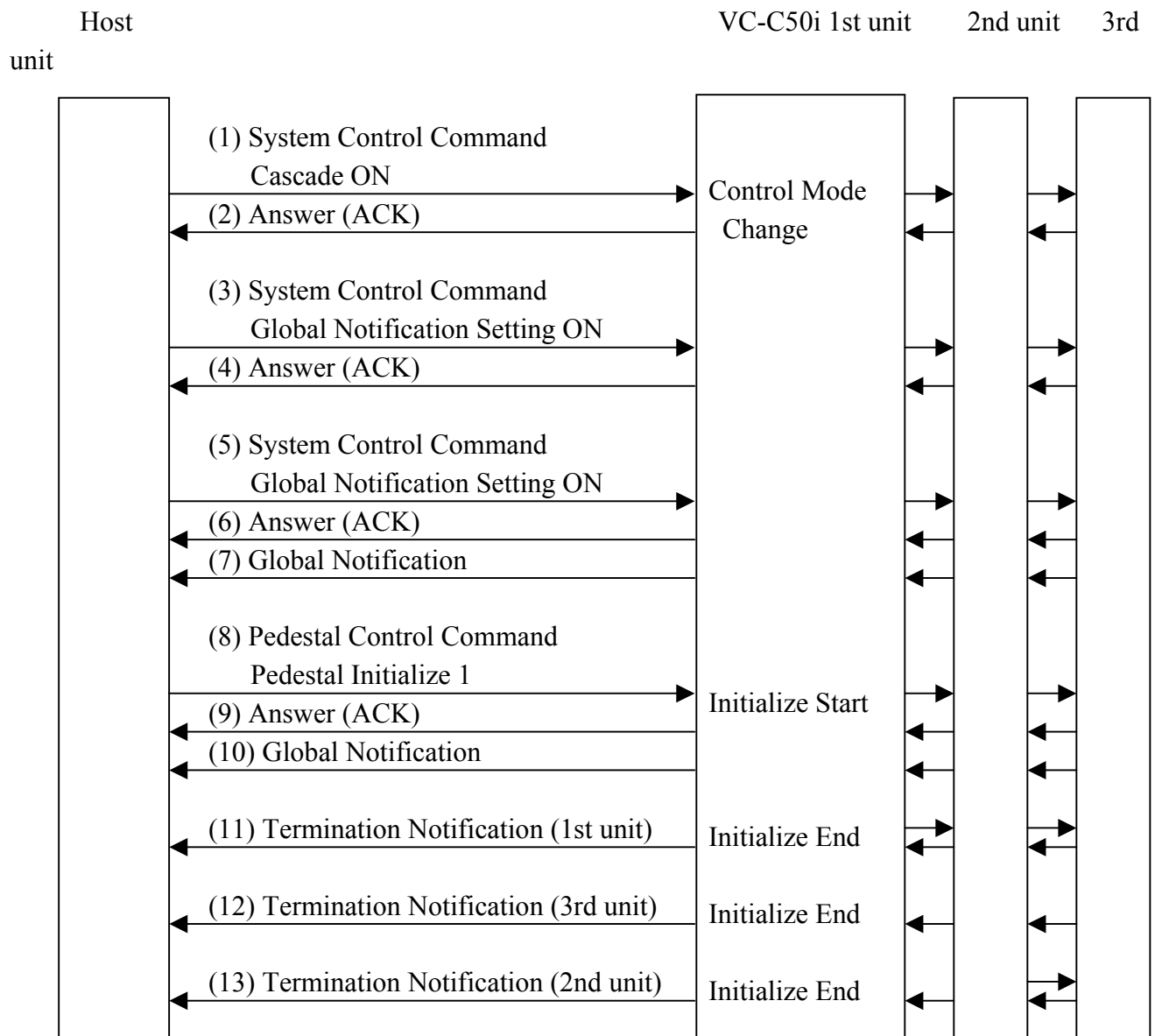

### Corresponding Frame Code

	Command/Answer
(1)	FF 30 30 00 8F 31 EF
(2)	FE 30 33 30 30 EF
(3)	FF 30 30 00 94 31 EF
(4)	FE 30 33 30 30 EF
(5)	FF 30 30 00 95 31 EF
(6)	FE 30 33 30 30 EF
(7)	F8 30 33 30 30 30 30 EF
(8)	FF 30 30 00 58 30 EF
(9)	FE 30 33 30 30 EF
(10)	F8 30 33 30 30 30 30 EF
(11)	FA 30 31 00 58 30 EF
(12)	FA 30 33 00 58 30 EF
(13)	FA 30 32 00 58 30 EF