

VADDIO™ PRODUCTIONVIEW™ PC EXPANDER

Video Scaler and PC Input for ProductionVIEW Consoles



Figure 1: ProductionVIEW PC Expander Front Panel Controls (top) and the Rear Panel Connections (bottom)

Overview:

The ProductionVIEW PC Expander is a 1-RU rack mountable video scaler/switcher that expands the capabilities of the ProductionVIEW Series of video consoles and controllers. The PC Expander essentially adds a PC input to any ProductionVIEW system and scales the video output of the ProductionVIEW or ProductionVIEW FX up to the resolution of a PC for matched resolution display on large format projectors (image magnification systems). The PC Expander has a PC loop-through and video input (S-video, composite video and std. definition component) with a RGB/Y_BP_R output and is controlled through RS-232, front panel or IR Remote. When connected to the camera control port six (6) of the ProductionVIEW console, the PC Expander is automatically recognized and control port 6 of the ProductionVIEW is automatically configured to switch the input of the PC Expander between video and the PC inputs on the MAIN bus.

The ProductionVIEW PC Expander can be used as a standalone scaler for scaling up S-Video, composite and std. definition video to RGBHV or Y_BP_R HDTV resolutions. The PC input is a loop-through and is not processed so the original integrity and resolution of the PC signal is preserved.

The PC Expander is an easy and economical way of scaling up the video output of the ProductionVIEW or ProductionVIEW FX to match the resolution of a PC for use with large format display systems.

Intended Use:

Before operating the Vaddio ProductionVIEW PC Expander, please read the entire manual thoroughly. The system was designed, built and tested for use indoors, and with the provided power supply and cabling. The use of a power supply other than the one provided or outdoor operation has not been tested and could damage the camera and/or create a potentially unsafe operating condition.

Save These Instructions:

The information contained in this manual will help you install and operate your Vaddio ProductionVIEW PC Expander. If these instructions are misplaced, Vaddio keeps copies of Specifications, Installation and User Guides and most pertinent product drawings for the Vaddio product line on the Vaddio website. These documents can be downloaded from www.vaddio.com free of charge.

Important Safeguards:

Read and understand all instructions before using. Do not operate any device if it has been dropped or damaged. In this case, a Vaddio technician must examine the product before operating. To reduce the risk of electric shock, do not immerse in water or other liquids and avoid extremely humid conditions.



**Use only the power supply provided with the ProductionVIEW PC Expander.
Use of any unauthorized power supply will void any and all warranties.**

UNPACKING:

Carefully unpack and identify the following parts from the packaging.

The ProductionVIEW PC Expander, Part Number 999-5400-000 (North American model) includes:

- One (1) ProductionVIEW PC Expander
- One (1) 12VDC 1Amp Power Supply with North America AC Cord
- One (1) VGA Cable 15-PinHD to 15-PinHD
- One (1) HD-15 D-Sub to YPbPr 3-RCA Cable
- One (1) RCA to RCA Video Cable
- One (1) S-Video Cable
- One (1) 3-RCA to 3-RCA YP_BP_R Cable
- Four (4) RCA-F to BNC Adapters
- One (1) RS-232 Control Adapter (DB-9M to RJ-45)
- One (1) IR Remote Control
- User Manual

The ProductionVIEW PC Expander, Part Number 999-5400-001 (International model) includes:

- One (1) ProductionVIEW PC Expander
- One (1) 12VDC 1Amp Power Supply with Euro and UK AC Cord
- One (1) VGA Cable 15-PinHD to 15-PinHD
- One (1) HD-15 D-Sub to YPbPr 3-RCA Cable
- One (1) RCA to RCA Video Cable
- One (1) S-Video Cable
- One (1) 3-RCA to 3-RCA YP_BP_R Cable
- Four (4) RCA-F to BNC Adapters
- One (1) RS-232 Control Adapter (DB-9M to RJ-45)
- One (1) IR Remote Control
- User Manual

Key Features:

- Video inputs are de-interlaced and scaled up to the following output resolutions:
 - For PC: 640x 480, 800x 600 (SVGA), 1024 x 768 (XGA), 1280 x 1024 (SXGA),
 - For HDTV: 852 x 480p, 852 x 576p, 1280x720p, 1920x1080i (interlaced)
- Automatically accommodates input video systems of NTSC 3.58 and PAL.
- High performance adaptive 3D Comb filter Y/C separator.
- Per-pixel motion compensated de-interlacing algorithms to produce artifact-free progressive scan video.
- Built in Adaptive film mode 3:2 pull-down provides clear and crisp de-interlacing of video originating from 24 fps film, such as DVD movies.
- Vertical temporal filter (VT) removes jaggy and other de-interlacing artifacts from normal video.
- OSD menu with adjustable control on Color, Sharpness, Brightness, Contrast and Tint (NTSC).
- Built-in DCTI/DLTI circuit for color/luminance transient improvement.
- The PC loop-through allows for easy switching between video and PC signals.
- Last memory for all adjustments.
- RS-232 interface allows control from external controllers (ProductionVIEW, AMX®, Crestron®)

Operating the ProductionVIEW PC Expander:

The PC Expander can be used in stand- alone mode or it can be used with the ProductionVIEW or ProductionVIEW FX video consoles. When setting up the PC Expander, use the front panel buttons or IR remote control and the functions and values will be displayed by the OSD (On Screen Display).

The PC Expander can be controlled from external control systems and switching between video input and PC input can be controlled through a simple connection between the PC Expander and the ProductionVIEW and ProductionVIEW FX.

Front Panel Controls:

Figure 2:
Front Panel Controls of the PC Expander

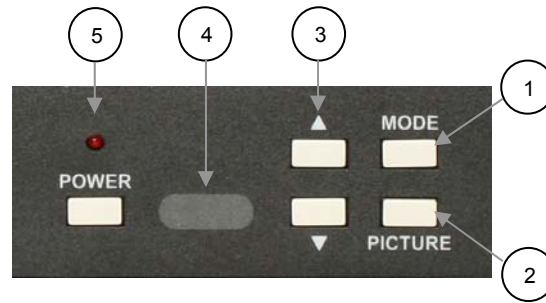

1) Mode:

Pressing the Mode button will toggle through the following adjustment controls:

- **Source Mode**
Use the ▲ ▼ buttons to pick video source: Video, S-Video or Component
- **Resolution Mode**
 - If RGB output mode is selected, use the ▲ ▼ buttons to choose from 640x480 (VGA), 800x600 (SVGA), 1024x768 (XGA) or 1280x1024 (SXGA) PC Output
 - If YP_BP_R output mode is selected use the ▲ ▼ buttons to choose from 480p, 576p, 720p or 1080i
- **Output Mode**
Use the ▲ ▼ buttons to choose between PC RGB output and HDTV YP_BP_R output.
- **Aspect Mode**
Use the ▲ ▼ buttons to choose between standard 4:3 aspect and wide 16:9 aspect ratio.
- **3D Enhance Mode**
Turn on or off the 3D comb filter function.
- **Digital NR Mode**
Turn on or off the digital noise reduction function.

2) Picture:

Controls the following picture parameters:

- **Contrast** - Press the ▲ ▼ buttons to adjust contrast (Range 0-63, Default is 58).
 - **Bright** - Press the ▲ ▼ buttons to adjust brightness (Range 0-63, Default is 31).
 - **Color** - Press the ▲ ▼ buttons to adjust color (Range 0-63, Default 31).
 - **Tint (NTSC Tint only)** - Press the ▲ ▼ buttons to adjust the NTSC tint level (Range 0-63, Default 31).
 - **Sharpness** - Press the ▲ ▼ buttons to adjust the sharpness level (Range 0-63, Default 10).
- 3) **Adjustment of values up/down:** Press the ▲ ▼ buttons toggle through various adjustment controls or change the values of specific parameters

4) **IR Sensor Window:** Point IR Remote at this window to operate the PC Expander

5) **Power LED and Button:** Power on/off - LED illuminates when power is on.

Notes:

- In Picture adjust mode, press ▲ and ▼ simultaneously and that parameter will return to factory default.
- By pressing both ▲ and ▼ buttons for over 5 seconds, all picture parameters will be set back to factory default.

Connecting the Video Inputs:

The PC Expander video scaler can accept composite video, S-Video or analog component video input signals for scaling. The PC input signal is passed through to the RGB output and is not processed. The rear panel connections (Figure 3) are as follows:

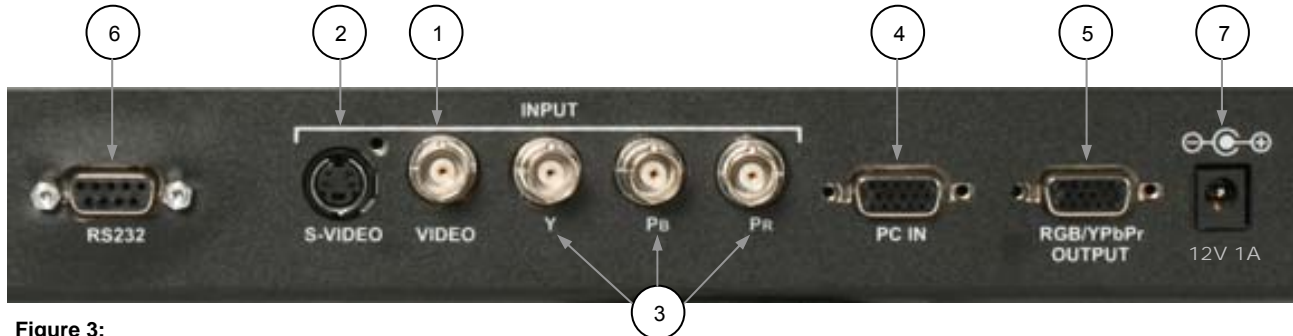

Figure 3:
Rear Panel of the ProductionVIEW PC Expander

- 1) **Composite Video** - Composite video input on a BNC connector.
- 2) **S-Video** - Input on 4-Pin mini din connector - offers improved performance and is recommended highly over composite video input.
- 3) **YP_BP_R Input** - Analog component video input on 3-BNC connectors (Note the YP_BP_R input does not get scaled or converted to RGBHV).
- 4) **PC Input - RGBHV input on DB-15HD female connector** (The PC Input is not processed or scaled and is a pass-through only).
- 5) **RGB/ YP_BP_R Output** - RGBHV or YP_BP_R analog component output on DB-15HD female connector.
 - Composite Video and S-Video inputs are scaled to either PC or YP_BP_R output.
 - YP_BP_R input can be scaled and output as a different YP_BP_R resolution (i.e. 480p scaled to 720p).
 - PC Input is not scaled and is a pass-through only.
- 6) **RS-232** - 9-Pin D-Sub female connector for connecting to external controllers.
- 7) **Power** - 12VDC Power Adapter - Use only the power supply provided.

Connecting the PC Expander to the ProductionVIEW Consoles:

The PC Expander input switching can be controlled with the ProductionVIEW and ProductionVIEW FX video consoles. To connect the ProductionVIEW consoles up to the PC Expander follow these steps:

- 1) With both units off, use the provided Control adapter and a Cat. 5 patch cable (not provided) and connect the RS-232 control port of the PC Expander to Camera Control Port 6 on the ProductionVIEW Console (Figure4).



Figure 4:
Camera Control Port 6 of the ProductionVIEW (FX) is connected to the RS-232 port on the PC Adapter with the supplied RJ-45 to DB-9M Control Adapter and RJ-45 patch cable.

- 2) Connect the MAIN S-Video output of the ProductionVIEW to the S-Video Input of the PC Expander, connect the PC to the PC input and connect the RGB output to the RGBHV projector or large format display (Figure 5).

Figure 5: Video, PC and Display Connections

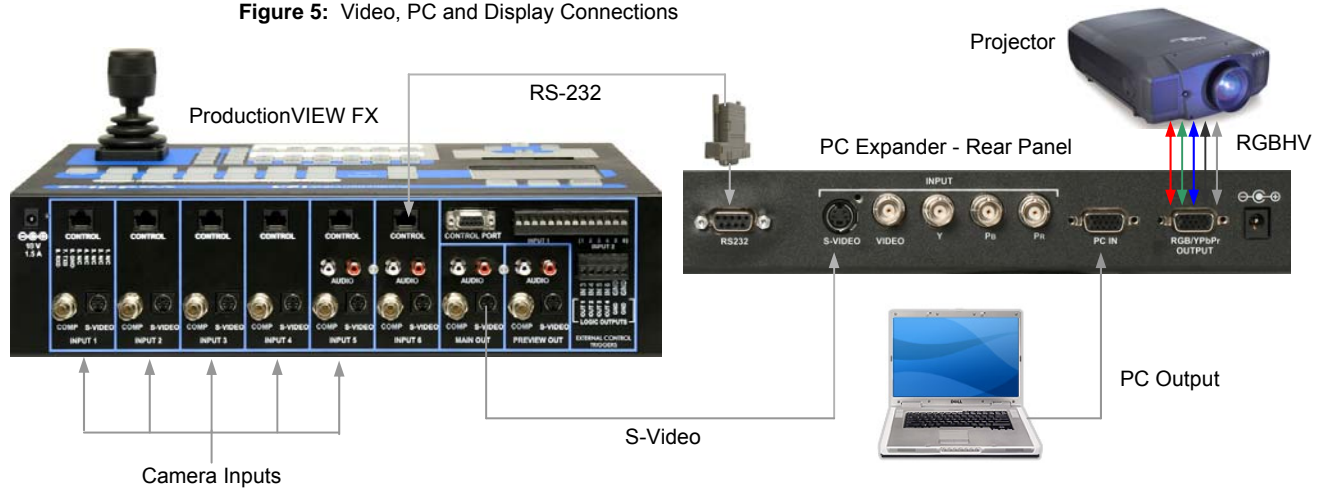

- 3) Turn on the PC Expander, then Turn on the ProductionVIEW Console and let it boot up. The ProductionVIEW will auto-sense the PC Expander in Port 6 and configure the MAIN bus to provide control over the input switching.

Note: The ProductionVIEW assumes that the Main output S-Video will be used as the input to the PC Expander and is the default video selection. If composite video is to be used as the input to the scaler, enter the menu system and change the PC Expander input to Composite video.

Operating the PC Expander from the ProductionVIEW Front Panel:

The PC Expander scaler input switching can be operated from the front panel of the ProductionVIEW Console. The ProductionVIEW PREVIEW bus will work normally. MAIN bus buttons 1 through 5 will work normally and when touched, will switch the S-Video (or composite video) through the scaler and out the RGB output to the RGBHV projector or large screen display. MAIN bus Input 6 button will route the PC input to the RGB output when touched. A slight delay is normal when switching between Video and PC inputs (Figure 6).

MAIN bus 1-5 switches S-Video (or composite) to the scaler and out the RGB Output

MAIN Bus Switch 6 routes the PC input directly to the RGB Output of the ProductionVIEW PC Expander

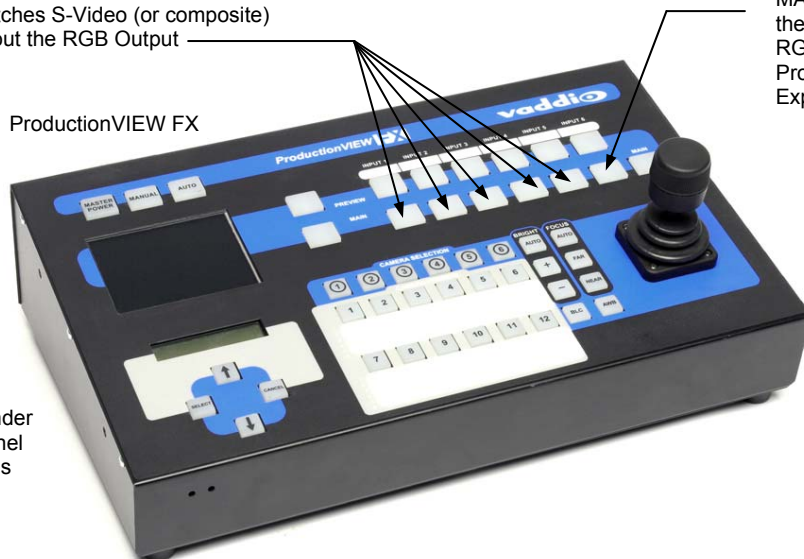
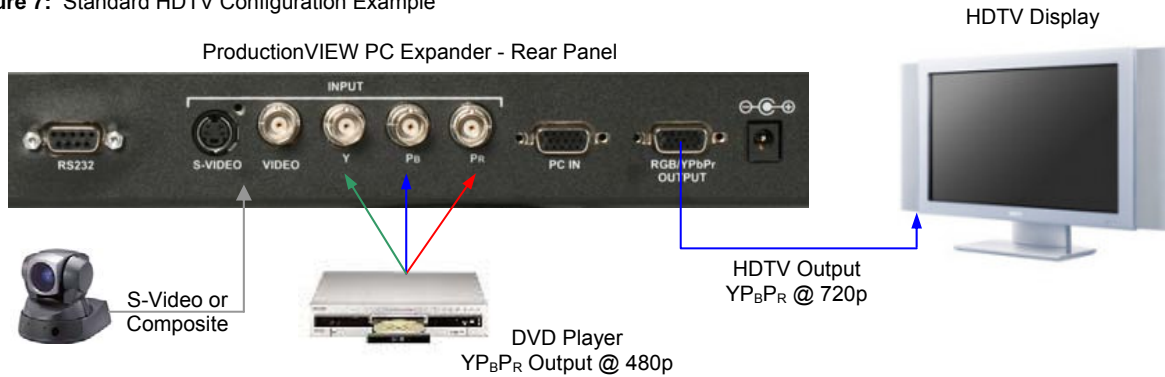

Figure 6: Controlling the PC Expander Scaler from the Front Panel with the MAIN bus buttons

Using the PC Expander as a Stand-alone Scaler:

The ProductionVIEW can be used as a stand-alone scaler to scale S-Video or composite video to RGBHV and analog component video to a higher resolution YP_BP_R output. The diagram below (Figure 7) depicts a standard stand-alone HDTV configuration example.

Figure 7: Standard HDTV Configuration Example



Using the IR Remote Control:

Each System ships with a CR-20 IR remote controller. The Functions of the CR-20 IR Remote are listed below (Figure 8).

- 1) **Power:** Power ON/OFF button.
- 2) **Display:** Press the button to enable or disable the on screen display of the resolution information.
- 3) **C-Video:** Press to select composite video as input source.
- 4) **S-Video:** Press to select S-Video as input source.
- 5) **YCbCr:** Press to select YP_BP_R as input source.
- 6) **PC:** Press to select PC input looping through to the output.
- 7) **VGA:** Press to select 640 x 480 as output resolution.
- 8) **SVGA:** Press to select 800 x 600 as output resolution.
- 9) **XGA:** Press to select 1024 x 768 as output resolution.
- 10) **SXGA:** Press to select 1280 x 1024 as output resolution.
- 11) **480p:** Press to select 852 x 480p as output resolution.
- 12) **576p:** Press to select 852 x 576p as output resolution.
- 13) **720p:** Press to select 1280 x 720p as output resolution.
- 14) **1080i:** Press to select 1920 x 1080i as output resolution.
- 15) **Aspect ratio:** Press to switch between standard (4:3) and wide (16:9) aspect ratio.
- 16) **IR-Set:** When front panel is locked out by RS-232, pressing this button for over 15 seconds will lift the lock out.
- 17) **3D:** Press to turn ON/OFF the 3D enhance mode
- 18) **NR:** Press to turn ON/OFF digital noise reduction.
- 19) **Mode:** Same as "Mode" button on front panel.
- 20) **Picture:** Same as "Picture" button on front panel.
- 21) **Reset:** Press this button to restore factory defaults

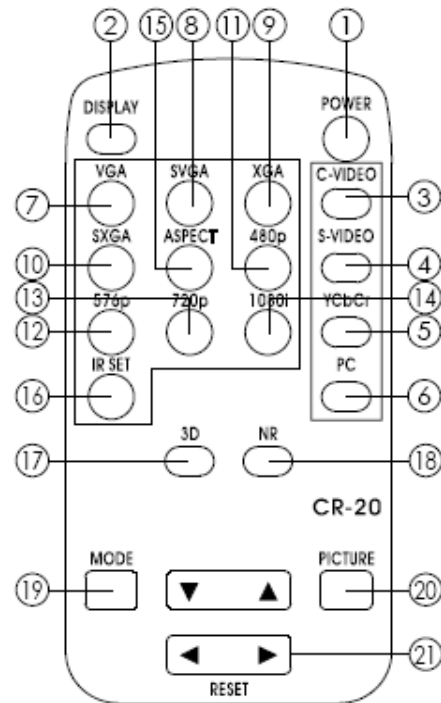

Figure 8: CR-20 IR Remote Controller

RS-232 Communication Specification

Baud Rate: 9600 bps

Stop bit: 1

Data bits: 8

Parity: None

ProductionVIEW PC Expander	
Pin Number	Definition
1	NC
2	TXD
3	RXD
4	NC
5	GND
6	NC
7	NC
8	NC
9	NC

Command	Response	Description
"[POWER1]"	"[POWER1]"	Power ON
"[POWER0]"	"[POWER0]"	Power OFF
"[INO]"	"[INO]"	Composite Video Input
"[IN1]"	"[IN1]"	S-Video Input
"[IN2]"	"[IN2]"	YPbPr Input
"[IN3]"	"[IN3]"	PC Input
"[OUTPC0]"	"[OUTPC0]"	PC - VGA Output
"[OUTPC1]"	"[OUTPC1]"	PC - SVGA Output
"[OUTPC2]"	"[OUTPC2]"	PC - XGA Output
"[OUTPC3]"	"[OUTPC3]"	PC - SXGA Output
"[OUTH0]"	"[OUTH0]"	HD 480p Output
"[OUTH1]"	"[OUTH1]"	HD 576p Output
"[OUTH2]"	"[OUTH2]"	HD 720p Output
"[OUTH3]"	"[OUTH3]"	HD 1080i Output
"[OSD0]"	"[OSD0]"	On Screen Display OFF
"[OSD1]"	"[OSD1]"	On Screen Display ON
"[DISPLAY0]"	"[DISPLAY0]"	Display OFF
"[DISPLAY1]"	"[DISPLAY1]"	Display ON
"[IR0]"	"[IR0]"	IR Sensor OFF
"[IR1]"	"[IR1]"	IR Sensor ON
"[PANEL0]"	"[PANEL0]"	Front panel lockout ON
"[PANEL1]"	"[PANEL1]"	Front panel lockout OFF
"[COMB0]"	"[COMB0]"	3D Enhance OFF
"[COMB1]"	"[COMB1]"	3D Enhance ON
"[DNR0]"	"[DNR0]"	Digital Noise Reduction OFF
"[DNR1]"	"[DNR1]"	Digital Noise Reduction ON
"[ASPECT0]"	"[ASPECT0]"	Aspect Ratio Standard
"[ASPECT1]"	"[ASPECT1]"	ASPECT Ratio 16:9
"[ASPECT2]"	"[ASPECT2]"	Aspect Ratio 4:3
"[CONTRAST]x"	"[CONTRAST]x"	Contrast x = 0~63
"[BRIGHTx]"	"[BRIGHTx]"	Brightness x = 0~63
"[COLORx]"	"[COLORx]"	Color x = 0~63
"[HUEx]"	"[HUEx]"	Hue x = 0~63
"[DETAILx]"	"[DETAILx]"	Detail x = 0~63
"[RESET]"	Video Adjustment Reset "[CONTRAST58]" "[HUE31]"	"[BRIGHT31]" "[DETATIL10]" "[COLOR31]"
"[STATUS]"	Retrieve ALL Video Scaler Status "[POWER?]" "[OUTH?]" "[IR?]" "[DNR?]" "[BRIGHT?]" "[DETAIL?]"	"[IN?]" "[OSD?]" "[PANEL?]" "[ASPECT?]" "[CONTRAST?]" "[HUE?]" "[OUTPC]" "[DISPLAY?]" "[COMB?]" "[CONTRAST?]" "[HUE?]"



General Specifications:

ProductionVIEW PC Expander				
PC Input (Loop)		RGBS (H&V), 1600 x 1200 Max Resolution		
PC Input Connector		15-Pin HD Female		
PC Input Signal Level		RGB @ 0.7V, H&V Sync @ TTL		
Video Inputs		Composite Video @ 1 Vp-p 75 ohm S-Video @ 1 Vp-p 75 ohm YP _B P _R : Y: 1 Vp-p 75 ohm, P _B P _R : 0.7 Vp-p 75 ohm		
Video Formats		NTSC and PAL		
Video Input Connectors		Composite: BNC S-Video: 4-Pin Mini Din Component: BNC		
Scaled Output Resolutions	PC Resolutions	VGA 640 x 480 SVGA 800 x 600 XGA 1024 x 768 SXGA 1280 x 1024	RGBHV RGBHV RGBHV RGBHV	Progressive Progressive Progressive Progressive
	HDTV Resolutions	16:9 - 1280 x 720p (720p) 16:9 - 1920 x 1080i (1080i) 852 x 480p (480p) 852 x 576p (576p)	YP _B P _R YP _B P _R YP _B P _R YP _B P _R	Progressive Interlaced Progressive Progressive
Scaled output vertical refresh rates & Horizontal scan rates		Output Resolution VGA SVGA XGA SXGA 480p 576p 720P 1080i	Vertical (HZ) 59.94 60.32 60.00 60.02 59.94 50 59.94 59.94	Horiz (HZ) 31.469 37.88 48.36 63.981 31.469 31.25 44.995 33.716
Control		Front Panel Buttons, IR Remote Control, RS-232 via Rear Panel DB-9F and ProductionVIEW Integrated Switching from MAIN Bus Assignment		
Video Adjustments		Brightness, Contrast, Color Saturation, Tint (NTSC), Sharpness		
Weight		2.2lbs (1 Kg)		
Dimensions		6" (154) Wide x 8" (204mm) Deep x 1.8" (46mm) Tall		
Power source		100~240VAC to 12VDC/1A Switching Power Supply		
Firmware Requirements		A Firmware upgrade will be required for existing ProductionVIEW consoles.		



Warranty Information:

Hardware* Warranty - One year limited warranty on all parts. Vaddio warrants this product against defects in materials and workmanship for a period of one year from the day of purchase from Vaddio. If Vaddio receives notice of such defects during the warranty period, they will, at their option, repair or replace products that prove to be defective.

Exclusions - The above warranty shall not apply to defects resulting from: improper or inadequate maintenance by the customer, customer applied software or interfacing, unauthorized modifications or misuse, operation outside the normal environmental specifications for the product, use of the incorrect power supply, improper extension of the power supply cable or improper site operation and maintenance.

Vaddio Customer service – Vaddio will test, repair, or replace the product or products without charge if the unit is under warranty and is found to be defective. If the product is out of warranty, Vaddio will test then repair the product or products. The cost of parts and labor charge will be estimated by a technician and confirmed by the customer prior to repair. All components must be returned for testing as a complete unit. Vaddio will not accept responsibility for shipment after it has left the premises.

Vaddio Technical support - Vaddio technicians will determine and discuss with the customer the criteria for repair costs and/or replacement. Vaddio Technical Support can be contacted through one of the following resources: e-mail support at support@vaddio.com or online at www.vaddio.com.

Return Material Authorization (RMA) number - Before returning a product for repair or replacement, request an RMA from Vaddio's technical support. Provide a technician with a return phone number, e-mail address, shipping address, and product serial numbers and describe the reason for repairs or returns as well as the date of purchase and proof of purchase. Include your assigned RMA number in all correspondence with Vaddio. Write your assigned RMA number on the outside of the box when returning the product.

Voided warranty – The warranty does not apply if the original serial number has been removed or if the product has been disassembled or damaged through misuse, accident, modifications, or unauthorized repair. Cutting the power supply cable on the secondary side (low voltage side) to extend the power to the device (camera or controller) voids the warranty for that device.

Shipping and handling - Vaddio will not pay for inbound shipping transportation or insurance charges or accept any responsibility for laws and ordinances from inbound transit. Vaddio will pay for outbound shipping, transportation, and insurance charges for all items under warranty but will not assume responsibility for loss and/or damage by the outbound freight carrier. If the return shipment appears damaged, retain the original boxes and packing material for inspection by the carrier. Contact your carrier immediately.

Products not under warranty - Payment arrangements are required before outbound shipment for all out of warranty products.

**Vaddio manufactures its hardware products from parts and components that are new or equivalent to new in accordance with industry standard practices.*

Other General Information:

Care and Cleaning

Do not attempt to take this product apart at any time. There are no user-serviceable components inside.

- Do not spill liquids in the ProductionVIEW Super Joystick
- Keep this device away from food and liquid
- For smears or smudges on the console, wipe with a clean, soft cloth.
- Do not use any strong or abrasive chemicals.

Operating and Storage Conditions:

Do not store or operate the ProductionVIEW Super Joystick under the following conditions:

- Temperatures above 40°C (104°F) or temperatures below 0°C (32°F)
- High humidity, condensing or wet environments
- In inclement weather
- Dusty environments
- Under severe vibration



Toll Free: 800-572-2011 ▪ Phone: 763-971-4400 ▪ FAX: 763-971-4464

www.vaddio.com